

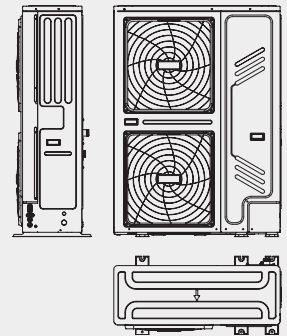

NXHM 018-030

Monobloc air-water heat pumps

Reversible air-water "quiet operation" heat pump with helioidal fans 18 kW - 30 kW, with R32 ecological refrigerant.



HEAT PUMPS

Air-water heat pumps

NXHM 018-030

PRODUCT DESCRIPTION

NXHM 018-030 is the ideal solution for any type of residential and commercial heating and cooling application, and can produce energy-efficient domestic hot water. The unit works with R32 ecological refrigerant, guaranteeing not only low global warming potential (GWP) and low CO2 emissions, but also optimum energy efficiency over the whole operating range.

NXHM 018-030 is also fitted with new exchange coils with the special hydrophilic and anti-corrosion Blue-Fin treatment that improves the drainage of condensate on the fins, thereby reducing the risk of the coils freezing (maximum efficiency even in damp climates).

The unit is a monobloc, meaning that all components are housed inside, making installation easier and faster.

NXHM 018-030 comes with climate control as standard, and is available in 4 models, ranging from 18 to 30 kW.

- Twin rotary compressor with DC inverter technology which modulates the output to adapt perfectly to the real load needed.
- High COP and EER values (all the NXHM heat pumps comply with the highest standards requested in terms of energy efficiency).
- Performance ratings certified by the third party body HP Keymark.
- They can be connected to low-temperature radiators, radiant floor elements and fan convector type units.
- Water heating temperature up to +60°C.
- Easy, quick installation.
- Low unit noise level.
- Wired control panel included, for the complete management of a heating/ cooling/ DHW system.
- The control panel can manage up to 6 units (even of different output levels) in cascade format - 1 master and 5 slaves.
- Anti-freeze protection as standard, to protect the entire system - in particular the hydraulic parts - from the potential damage caused by freezing.

TECHNICAL DATA NXHM 018T-010

	Model	UM	NXHM 018T	NXHM 022T	NXHM 026T	NXHM 030T
PERFORMANCE DATA IN HEATING						
Performance in heating (A7°C; W35°C)						
	Nominal capacity	kW	18.00	22.00	26.00	30.10
	Power input	kW	3.83	5.00	6.37	7.70
	COP		4.70	4.40	4.08	3.91
	SCOP (temperate zone)		4.6	4.53	4.5	4.19
	Seasonal energy efficiency	%	181	178	177	165
	Energy class		A+++	A+++	A+++	A++
Performance in heating (A7°C; W45°C)						
	Nominal capacity	kW	18.00	22.00	26.00	30.00
	Power input	kW	5.14	6.47	8.39	10.34
	COP		3.50	3.40	3.10	2.90
Performance in heating (A7°C; W55°C)						
	Nominal capacity	kW	18.00	22.00	26.00	30.00
	Power input	kW	6.55	8.30	10.61	13.04
	COP		2.75	2.65	2.45	2.30
	SCOP (temperate zone)		3.21	3.22	3.14	3.14
	Seasonal energy efficiency	%	125	126	123	123
	Energy class		A++	A++	A+	A+
PERFORMANCE DATA IN COOLING						
Performance in cooling (A35°C; W7°C)						
	Nominal capacity	kW	17.00	21.00	26.00	29.50
	Power input	kW	5.57	7.12	9.63	11.57
	EER		3.05	2.95	2.70	2.55
	SEER		4.70	4.70	4.66	4.49
	Seasonal energy efficiency	%	185	185	183	177

	Model	UM	NXHM 018T	NXHM 022T	NXHM 026T	NXHM 030T
Performance in cooling (A35°C; W18°C)						
Nominal capacity	kW		18.50	23.00	27.00	31.00
Power input	kW		3.89	5.00	6.28	7.75
EER			4.75	4.60	4.30	4.00
ELECTRICAL SPECIFICATIONS						
Electric power supply	V/ph/Hz		400/3/50	400/3/50	400/3/50	400/3/50
Total maximum input power (1)	kW		10.60	12.50	13.80	14.50
Total maximum input current (2)	A		16.80	19.60	21.60	22.80
COMPRESSOR						
Compressor	Type		Twin Rotary	Twin Rotary	Twin Rotary	Twin Rotary
Adjustment	Type		Inverter modulating	Inverter modulating	Inverter modulating	Inverter modulating
Minimum capacity control	%		24	24	24	24
Refrigerant	Type		R32	R32	R32	R32
GWP	CO2 equiv. in t/kg		675	675	675	675
Refrigerant load	kg		5.00	5.00	5.00	5.00
Control box load	CO2 equiv. in t		3.38	3.38	3.38	3.38
Number of circuits	no.		1	1	1	1
Hermetically sealed control box (EU reg. 517_2014)	yes/no		yes	yes	yes	yes
FAN						
Fan	Type		Axial	Axial	Axial	Axial
Quantity	no.		2	2	2	2
Maximum air flow rate	m ³ /h		10650	10650	11200	11200
HEAT EXCHANGER (SOURCE SIDE)						
Heat exchanger (source side)	Type		Grooved copper pipes, fins in hydrophilic aluminium with anti-corrosion treatment	Grooved copper pipes, fins in hydrophilic aluminium with anti-corrosion treatment	Grooved copper pipes, fins in hydrophilic aluminium with anti-corrosion treatment	Grooved copper pipes, fins in hydrophilic aluminium with anti-corrosion treatment
CIRCULATION PUMP						
Circulation pump	Type		3-speed centrifugal	3-speed centrifugal	3-speed centrifugal	3-speed centrifugal
Nominal flow rate	m ³ /h		3.10	3.79	4.48	5.19
Maximum operating pressure	bar		3	3	3	3
Maximum power input	kW		0.262	0.262	0.262	0.262
Maximum input current	A		1.20	1.20	1.20	1.20
Expansion vessel volume	l		8.00	8.00	8.00	8.00
HEAT EXCHANGER (SYSTEM SIDE)						
Heat exchanger (system side)	Type		With plates AISI316	With plates AISI316	With plates AISI316	With plates AISI316
Water content	l		3.5	3.5	3.5	3.5
SOUND DATA						
Sound power level (3)	dB(A)		71	73	75	77
Sound pressure at 1m (4)	dB(A)		57.6	59.8	61.5	63.5
WEIGHT						
Net weight	kg		177	177	177	177

The performance values comply with Standards UNI EN 14511 and UNI EN 14825. Performance data certified by HP Keymark.

(1) Power input from compressors and from fans and the circulation pump in the maximum operating conditions, with the nominal power supply voltage.

(2) Maximum unit operating current with the nominal power supply voltage.

(3) Sound emission values declared, in accordance with standard EN 12102-1.

(4) Measured in a semi-anechoic chamber, at a distance of 1m from the front of the unit and at a height from the floor equal to (1+H)/2, where H is the height of the unit expressed in meters (in accordance with standard EN 12102-1).

HEAT PUMPS

Air-water heat pumps

TECHNICAL DATA NXHM 018T-030T

Model	UM	NXHM 018T	NXHM 022T	NXHM 026T	NXHM 030T
Temperate zone - Low temperature (30/35°C) EU reg. 811_2013					
Seasonal energy efficiency	%	181	178	177	165
SCOP		4.60	4.53	4.50	4.19
Pdesignh at -7°C	kW	15.91	19.73	22.15	21.95
Pdesignh at +2°C	kW	9.67	12.04	13.78	16.22
Pdesignh at +7°C	kW	6.57	8.02	9.38	10.69
Pdesignh at +12°C	kW	3.77	3.81	4.11	4.59
Annual energy consumption	kWh/year	8086	10180	11489	14165
Energy class		A+++	A+++	A+++	A++
Sound power	dB(A)	71	73	75	77
Temperate zone - Medium temperature (47/55°C) EU reg. 811_2013					
Seasonal energy efficiency	%	125	126	123	123
SCOP		3.21	3.22	3.14	3.14
Pdesignh at -7°C	kW	15.64	19.84	20.65	20.12
Pdesignh at +2°C	kW	9.62	11.91	14.28	16.50
Pdesignh at +7°C	kW	6.40	7.99	9.30	10.51
Pdesignh at +12°C	kW	3.60	3.62	3.90	4.65
Annual energy consumption	kWh/year	11375	14390	17204	19316
Energy class		A++	A++	A+	A+
Hot zone - Low temperature (30/35°C)					
Seasonal energy efficiency	%	226	230	230	212
SCOP		5.74	5.85	5.85	5.39
Pdesignh at +2°C	kW	17.84	21.81	25.50	26.29
Pdesignh at +7°C	kW	11.36	14.08	16.77	19.57
Pdesignh at +12°C	kW	5.45	6.44	7.65	8.90
Annual energy consumption	kWh/year	4116	4945	5959	7540
Hot zone - Medium temperature (47/55°C)					
Seasonal energy efficiency	%	157	161	168	163
SCOP		4.00	4.09	4.26	4.15
Pdesignh at +2°C	kW	18.44	22.12	26.50	26.41
Pdesignh at +7°C	kW	11.62	14.15	16.86	19.11
Pdesignh at +12°C	kW	5.35	6.38	7.58	8.92
Annual energy consumption	kWh/year	6041	7180	8218	9580
Cold zone - Low temperature (30/35°C)					
Seasonal energy efficiency	%	147	146	143	139
SCOP		3.73	3.72	3.64	3.52
Pdesignh at -7°C	kW	11.21	13.30	15.91	18.49
Pdesignh at +2°C	kW	6.64	8.25	10.10	11.88
Pdesignh at +7°C	kW	4.77	5.45	6.30	7.53
Pdesignh at +12°C	kW	3.95	3.98	4.03	4.11
Annual energy consumption	kWh/year	11740	14179	17421	20390
Cold zone - Medium temperature (47/55°C)					
Seasonal energy efficiency	%	98	103	102	101
SCOP		2.50	2.62	2.59	2.56
Pdesignh at -7°C	kW	11.12	13.53	15.90	18.40
Pdesignh at +2°C	kW	6.65	8.61	10.17	11.23
Pdesignh at +7°C	kW	4.66	5.21	6.52	7.42
Pdesignh at +12°C	kW	3.74	3.74	3.63	3.64
Annual energy consumption	kWh/year	18156	21067	24967	29238

The performance values comply with Standards UNI EN 14511 and UNI EN 14825.

SOUND PRESSURE LEVEL

Model	UM	NXHM 018T	NXHM 022T	NXHM 026T	NXHM 030T
Sound pressure (1)	dB (2)	57.6	59.8	61.5	63.5

- (1) The sound pressure level is measured at a position 1 m in front of the unit and (1+H)/2 m (where H is the height of the unit) above the floor in a semi-anechoic chamber. During on-site operation, sound pressure levels may be higher due to ambient noise.
- (2) dB is the maximum value tested under the following conditions:
 Outdoor air temperature 7°C DB, 85% R.H.; EWT 30°C, LWT 35°C. Variable compressor frequency..
 Outdoor air temperature 7°C DB, 85% R.H.; EWT 47°C, LWT 55°C. Variable compressor frequency..

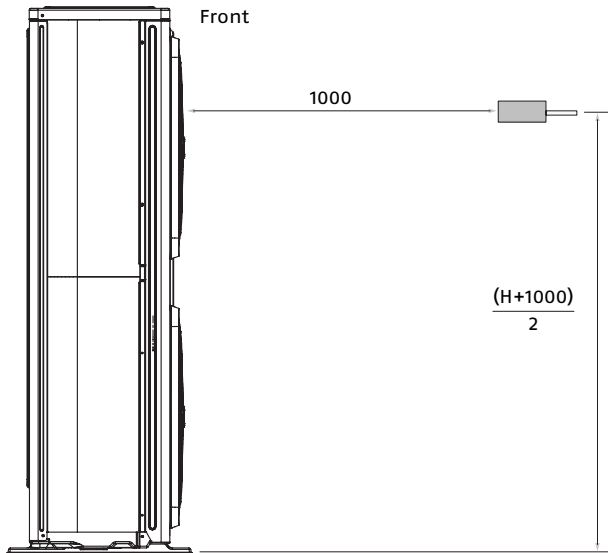

NXHM 018T – NR: Curve Noise Ratings

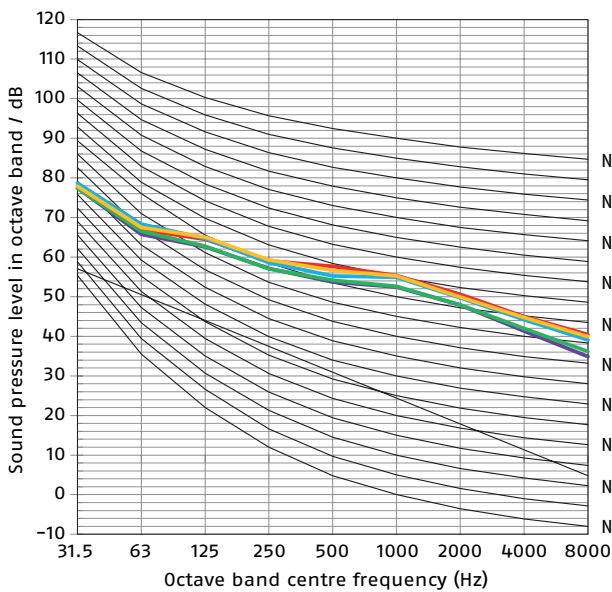

- Cooling at rated frequency
Outdoor air temperature 35°C dry bulb - Water inlet temperature 12°C - Water outlet temperature 7°C.
- Cooling at rated frequency
Outdoor air temperature 35°C dry bulb - Water inlet temperature 23°C - Water outlet temperature 18°C.
- Heating at rated frequency
Outdoor air temperature 7°C dry bulb - Relative humidity 85% - Water inlet temperature 30°C - Water outlet temperature 35°C.

NXHM 022T – NR: Curve Noise Ratings

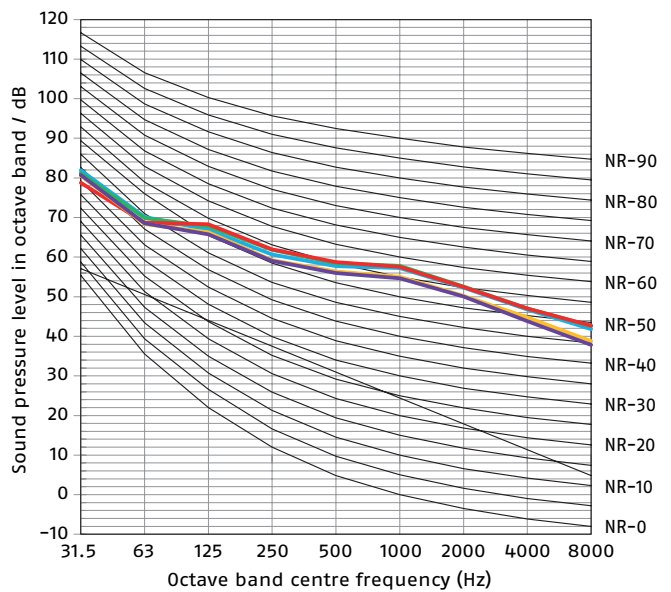

- Heating at rated frequency
Outdoor air temperature 7°C dry bulb - Relative humidity 85% - Water inlet temperature 40°C - Water outlet temperature 45°C.
- Heating at rated frequency
Outdoor air temperature 7°C dry bulb - Relative humidity 85% - Water inlet temperature 47°C - Water outlet temperature 55°C.
- Cooling at rated frequency
Outdoor air temperature 35°C dry bulb - Water inlet temperature 12°C - Water outlet temperature 7°C.
- Cooling at rated frequency
Outdoor air temperature 35°C dry bulb - Water inlet temperature 23°C - Water outlet temperature 18°C.

HEAT PUMPS

Air-water heat pumps

NXHM 026T – NR: Curve Noise Ratings

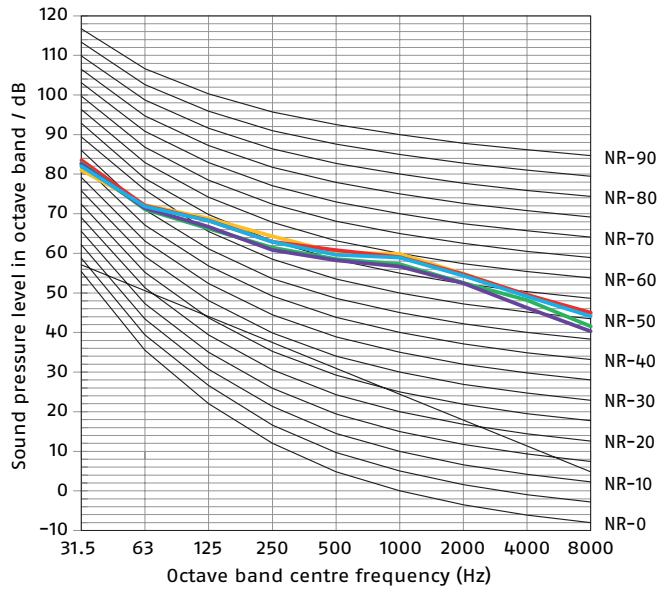

- Cooling at rated frequency
Outdoor air temperature 35°C dry bulb - Water inlet temperature 12°C - Water outlet temperature 7°C.
- Cooling at rated frequency
Outdoor air temperature 35°C dry bulb - Water inlet temperature 23°C - Water outlet temperature 18°C.
- Heating at rated frequency
Outdoor air temperature 7°C dry bulb - Relative humidity 85% - Water inlet temperature 30°C - Water outlet temperature 35°C.

NXHM 030T – NR: Curve Noise Ratings

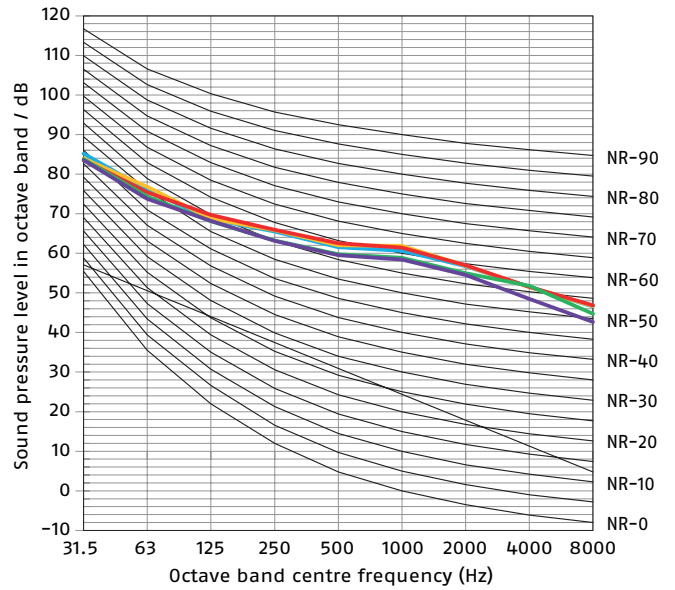

- Heating at rated frequency
Outdoor air temperature 7°C dry bulb - Relative humidity 85% - Water inlet temperature 40°C - Water outlet temperature 45°C.
- Heating at rated frequency
Outdoor air temperature 7°C dry bulb - Relative humidity 85% - Water inlet temperature 47°C - Water outlet temperature 55°C.
- Cooling at rated frequency
Outdoor air temperature 35°C dry bulb - Water inlet temperature 23°C - Water outlet temperature 18°C.

UNI TS 11300_3 E 4: PERFORMANCE IN ACCORDANCE WITH EN 14511 and EN 14825

NXHM 018T – HEATING

Delivery temperature	Performance with full load					
	35°C		45°C		55°C	
	Nominal capacity (kW)	COP	Nominal capacity (kW)	COP	Nominal capacity (kW)	COP
Outdoor temperature						
-7	19.91	2.37	16.16	1.98	10.08	1.18
2	20.23	3.16	19.97	2.64	17.74	2.15
7	18.00	4.70	18.00	3.50	18.00	2.75
12	21.22	4.17	19.34	3.60	18.57	2.90
15	22.08	4.32	20.89	3.89	19.18	3.22
20	23.78	4.46	21.28	4.08	20.38	3.44
35	12.48	6.58	11.91	5.24	11.13	3.81
Tbival (-7°C)	Performance with part load					
	A	B	C	D		
	Outdoor temperature (°C)	-7	2	7	12	
PLR - Climate load factor	0.88	0.54	0.35	0.15		
DC - Output with full load	19.91	20.23	18.00	21.22		
COP with full load	2.37	3.16	4.70	4.17		
COP with part load	2.85	4.59	5.99	7.08		
CR - Load factor	1.00	0.60	0.44	0.16		
f COP - Corrective factor	1.00	1.45	1.27	1.70		

NOTE: The performance values with a part load refer to a water outlet temperature of 35°C.

NXHM 018T – COOLING

	Load factor	Outdoor temperature (°C)	EER
EER1	100%	35	3.05
EER2	75%	30	4.13
EER3	50%	25	5.59
EER4	25%	20	5.55

NXHM 022T – HEATING

Delivery temperature	Performance with full load					
	35°C		45°C		55°C	
	Nominal capacity (kW)	COP	Nominal capacity (kW)	COP	Nominal capacity (kW)	COP
Outdoor temperature						
-7	21.28	2.44	19.82	2.03	12.55	1.25
2	23.24	3.02	23.02	2.51	21.04	2.12
7	22.00	4.40	22.00	3.40	22.00	2.65
12	25.95	3.99	24.15	3.37	22.99	2.822
15	28.05	4.13	26.31	3.56	24.59	3.11
20	27.75	4.33	25.97	3.77	23.95	3.30
35	12.46	6.48	11.88	5.17	11.20	3.81
Tbival (-7°C)	Performance with part load					
	A	B	C	D		
	Outdoor temperature (°C)	-7	2	7	12	
PLR - Climate load factor	0.88	0.54	0.35	0.15		
DC - Output with full load	21.28	23.24	22.00	25.95		
COP with full load	2.44	3.02	4.40	3.99		
COP with part load	2.74	4.41	6.29	7.14		
CR - Load factor	1.00	0.56	0.38	0.14		
f COP - Corrective factor	1.00	1.46	1.43	1.79		

NOTE: The performance values with a part load refer to a water outlet temperature of 35°C.

NXHM 022T – COOLING

	Load factor	Outdoor temperature (°C)	EER
EER1	100%	35	2.95
EER2	75%	30	3.95
EER3	50%	25	5.37
EER4	25%	20	6.19

HEAT PUMPS

Air-water heat pumps

NXHM 026T – HEATING

Delivery temperature	Performance with full load					
	35°C		45°C		55°C	
	Nominal capacity (kW)	COP	Nominal capacity (kW)	COP	Nominal capacity (kW)	COP
Outdoor temperature						
-7	23.46	2.52	21.45	2.08	15.28	1.31
2	25.44	2.90	26.17	2.40	23.10	2.09
7	26.00	4.08	26.00	3.10	26.00	2.45
12	29.34	3.82	28.67	3.17	26.05	2.75
15	30.79	3.95	30.62	3.30	26.56	3.00
20	32.48	4.21	30.13	3.53	26.78	3.18
35	12.43	6.38	11.85	5.10	11.26	3.81
Performance with part load						
Tbival (-7°C)	A	B	C	D		
Outdoor temperature (°C)	-7	2	7	12		
PLR – Climate load factor	0.88	0.54	0.35	0.15		
DC – Output with full load	23.46	25.44	26.00	29.34		
COP with full load	2.52	2.90	4.08	3.82		
COP with part load	2.57	4.44	6.52	7.35		
CR – Load factor	1.00	0.57	0.36	0.14		
f COP – Corrective factor	1.00	1.53	1.60	1.92		

NOTE: The performance values with a part load refer to a water outlet temperature of 35°C.

NXHM 026T – COOLING

	Load factor	Outdoor temperature (°C)	EER
EER1	100%	35	2.70
EER2	75%	30	3.79
EER3	50%	25	5.19
EER4	25%	20	6.84

NXHM 030T – HEATING

Delivery temperature	Performance with full load					
	35°C		45°C		55°C	
	Nominal capacity (kW)	COP	Nominal capacity (kW)	COP	Nominal capacity (kW)	COP
Outdoor temperature						
-7	24.85	2.54	25.43	2.13	19.93	1.56
2	26.02	2.86	28.19	2.29	24.65	1.97
7	30.10	3.91	30.00	2.90	30.00	2.30
12	31.14	3.67	33.35	3.01	31.14	2.68
15	32.70	3.79	36.01	3.09	32.59	2.90
20	32.70	4.08	35.34	3.33	32.48	3.06
35	12.41	6.29	11.82	5.03	11.33	3.80
Performance with part load						
Tbival (-7°C)	A	B	C	D		
Outdoor temperature (°C)	-7	2	7	12		
PLR – Climate load factor	0.88	0.54	0.35	0.15		
DC – Output with full load	24.85	26.02	30.10	31.14		
COP with full load	2.54	2.86	3.91	3.67		
COP with part load	2.54	4.16	6.38	7.72		
CR – Load factor	1.00	0.59	0.33	0.14		
f COP – Corrective factor	1.00	1.45	1.63	2.10		

NOTE: The performance values with a part load refer to a water outlet temperature of 35°C.

NXHM 030T – COOLING

	Load factor	Outdoor temperature (°C)	EER
EER1	100%	35	2.55
EER2	75%	30	3.62
EER3	50%	25	5.06
EER4	25%	20	6.75

OPERATING LIMITS NXHM

COOLING MODE

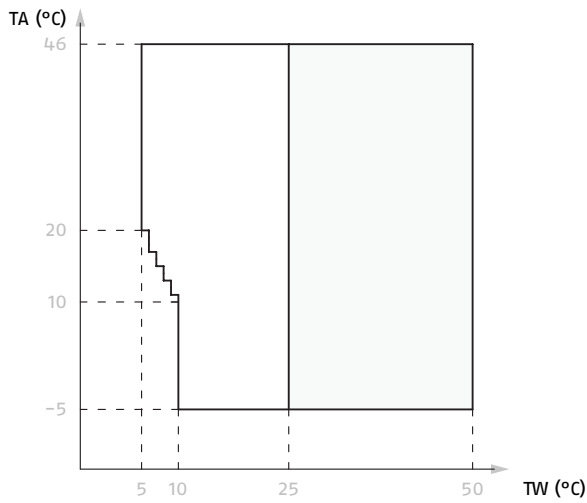

TA Outdoor air temperature
TW Water delivery temperature.

Operating range with heat pump, with possible limits and protection.

HEATING MODE

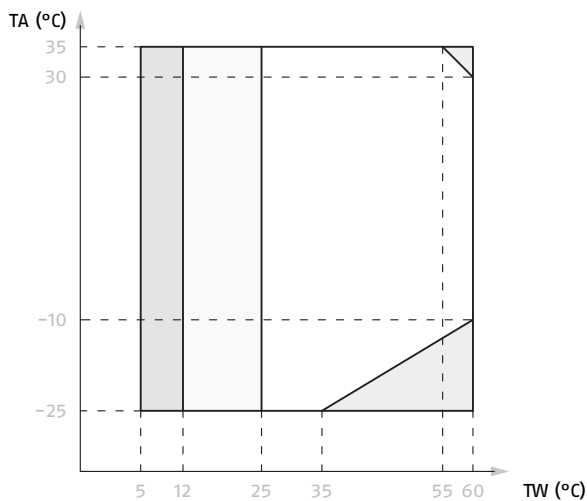

TA Outdoor air temperature
TW Water delivery temperature.

Operating range with heat pump, with possible limits and protection.
The heat pump switches off and only the external heat source is active.
If the external heat source setting is enabled, only the external heat source activates.
If the external heat source setting is disabled, only the heat pump is active. Limitations and protection may arise while the heat pump is operating.

DHW MODE

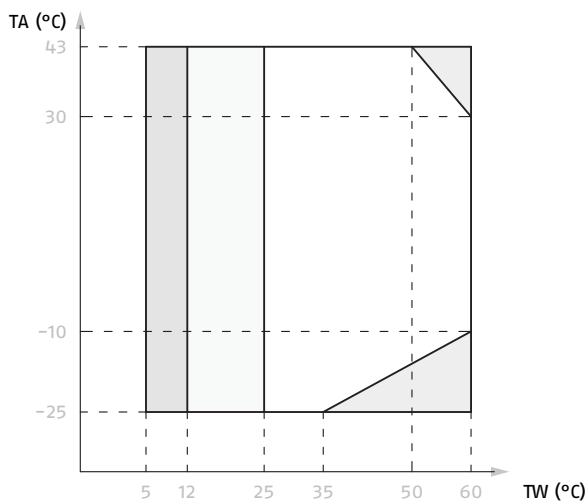

TA Outdoor air temperature
TW Water delivery temperature.

Operating range with heat pump, with possible limits and protection.
The heat pump switches off and only the external heat source is active.
If the external heat source setting is enabled, only the external heat source activates.
If the external heat source setting is disabled, only the heat pump is active. Limitations and protection may arise while the heat pump is operating.

HEAT PUMPS

Air-water heat pumps

OVERALL DIMENSIONS

NXHM 018T-030T

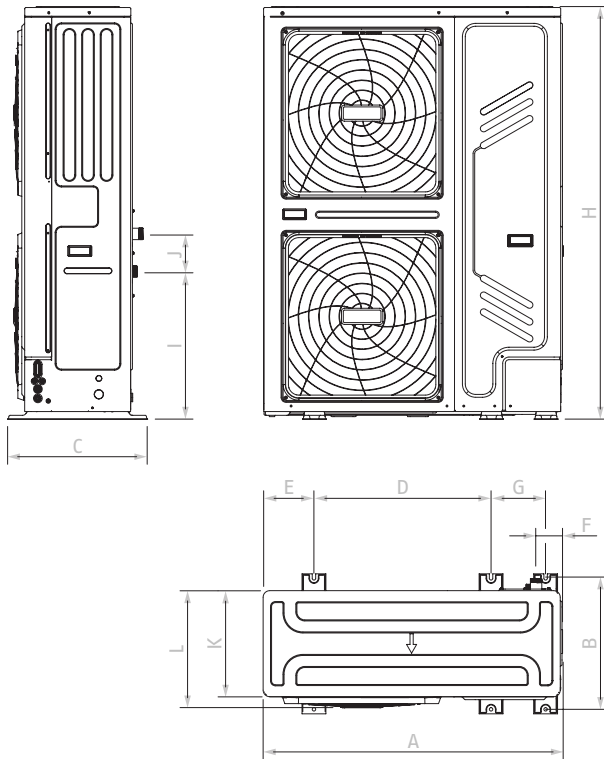

NXHM 018T-030T		
A	mm	1129
B	mm	494
C	mm	528
D	mm	668
E	mm	192
F	mm	98
G	mm	206
H	mm	1558
I	mm	558
J	mm	143
K	mm	400
L	mm	440

PLACE OF INSTALLATION

The unit is equipped with flammable refrigerant and must be installed outdoors in a well-ventilated place. Make sure that appropriate measures are taken to prevent the unit from being used as a shelter by small animals.

Choose an installation site that meets the following conditions:

- Well-ventilated.
- In an area which will not disturb any neighbours.
- On a level surface able to support the weight of the unit as well as any vibrations.
- In an area allowing maintenance to be carried out.

When installing the unit in a location exposed to strong wind, pay special attention to the following.

Strong winds of 5 m/sec or more blowing against the air outlet of the unit may cause a short circuit (exhaust air intake), which could have the following consequences:

- Deterioration of operational capacity.
- Frequent frost acceleration when operating in heating mode.
- Interruption of operation due to increased high pressure.
- When a strong wind blows continuously on the front of the unit, the fan can start to rotate quickly causing it to break.

When using the unit in cold climates, observe the instructions provided below:

- Never install the unit in a place where the intake side can be directly exposed to the wind.
- In areas with heavy snowfall, it is extremely important to choose an installation site where snow will not affect the device. If it is possible for snow to fall from the side, make sure that the heat exchanger coil is not affected by snow (if necessary, build a canopy).
- Install the unit high enough to prevent it from being buried in snow.

In normal conditions

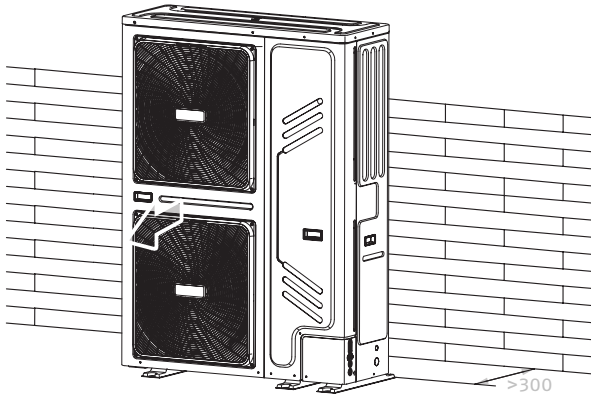

In conditions of high wind

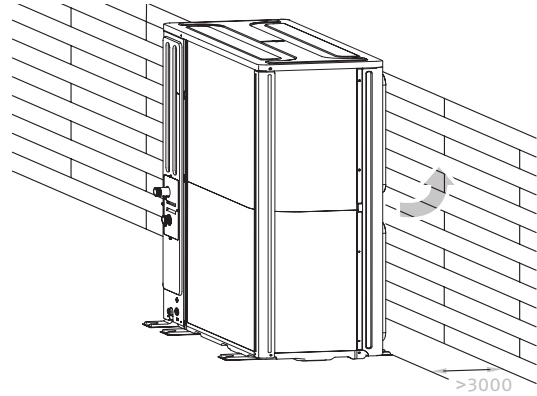

In a cold climate

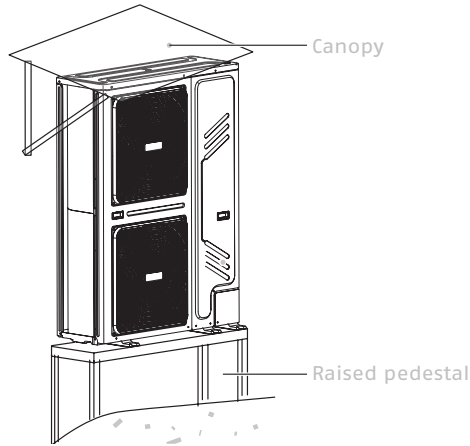

In the event of parallel installation on one row

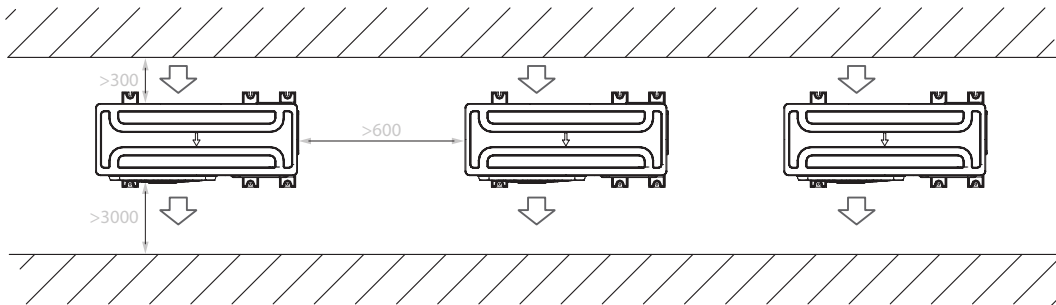

In the event of parallel installation on multiple rows

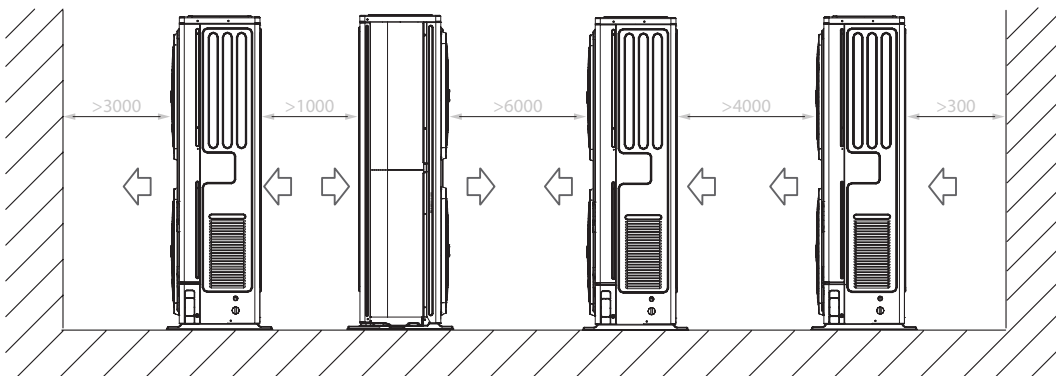

HEAT PUMPS

Air-water heat pumps

PLUMBING CONNECTIONS

NXHM 018T-030T

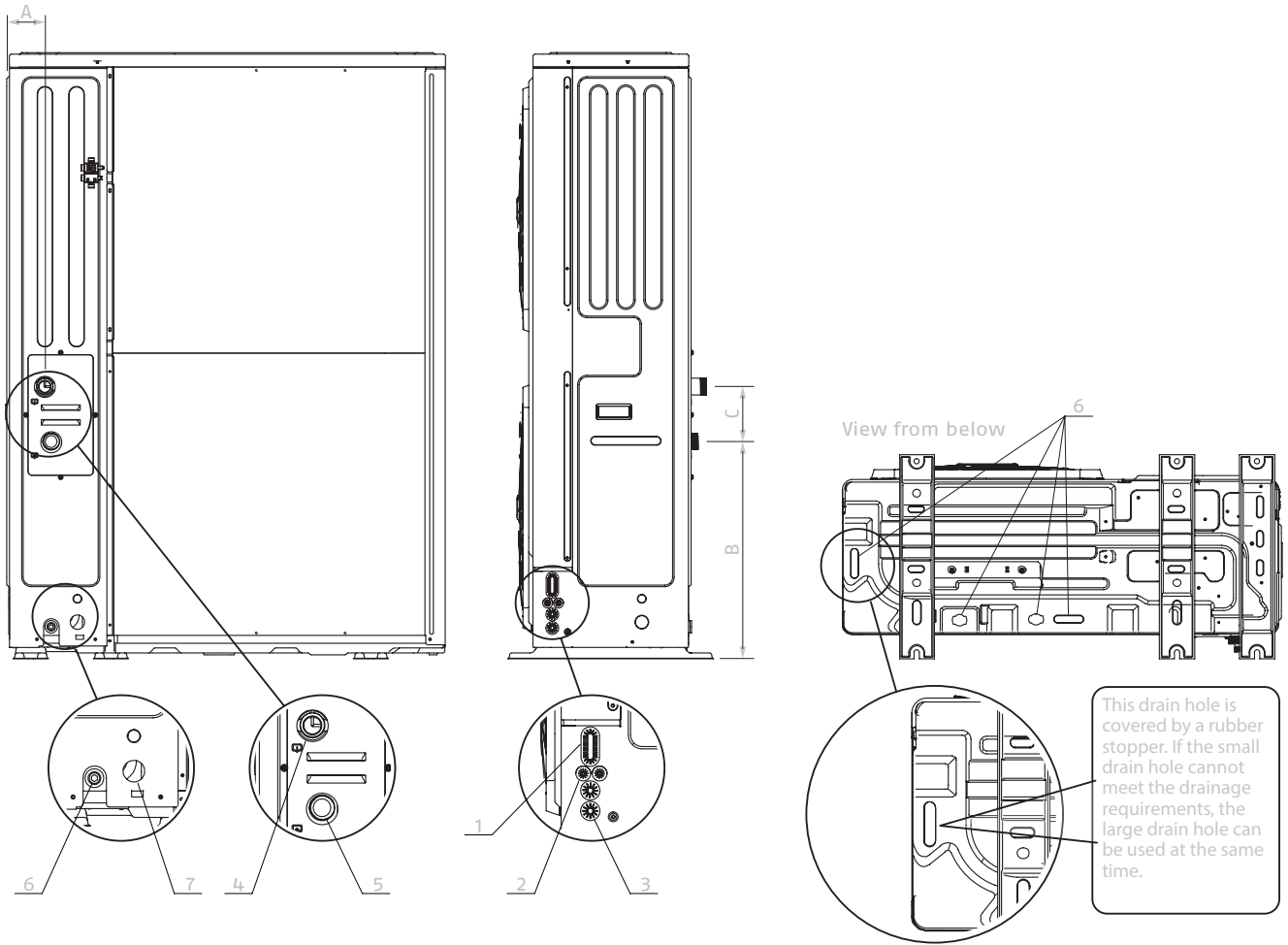

	Model	UM	NXHM 018T-030T
1	Hole for the HV wire	∅ mm	25
2	Hole for the LV wire	∅ mm	15
3	Hole for the HV or LV cable	∅ mm	15
4	Water outlet	∅	1 1/4"
5	Water inlet	∅	1 1/4"
6	Condensate outlet hose fitting (included)	∅ mm	35
7	Hole for safety valve drain pipe	∅ mm	15
A		mm	98
B		mm	558
C		mm	143

HYDRAULIC MODULE

NXHM 018T-030T

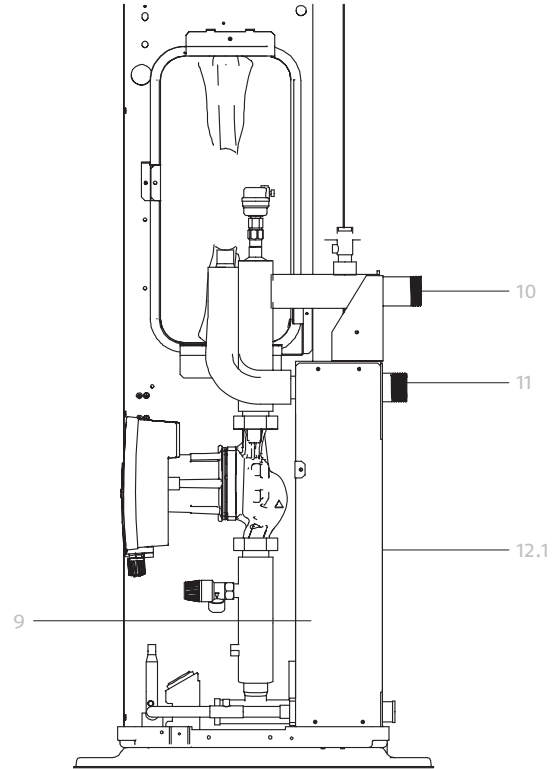
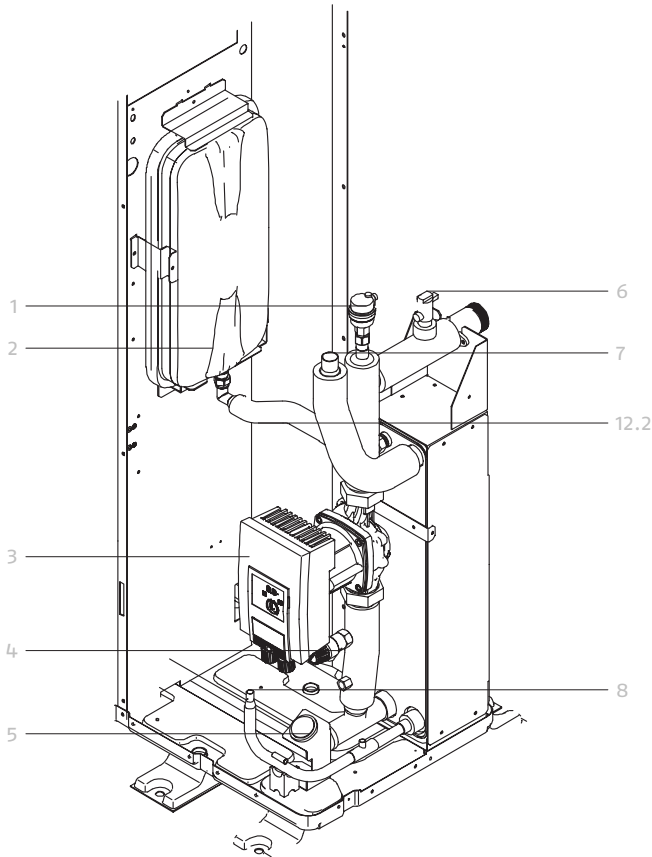

	Installation unit	Description
1	Air bleed valve	The air remaining in the water circuit will be automatically removed from the water circuit
2	Expansion vessel	Balances the pressure of the water system (volume of the expansion vessel: 8 l)
3	Circulation pump	Circulates water in the water circuit
4	Pressure relief valve	Prevents excessive water pressure by opening at 3 bar and draining water from the water circuit
5	Pressure gauge	Provides the water circuit pressure reading
6	Flow switch	Detects the water flow rate to protect the compressor and water pump in the event of insufficient water flow
7	Refrigerant gas connection	/
8	Refrigerant liquid connection	/
9	Plate heat exchanger	Transfers heat from the refrigerant to the water
10	Water outlet connection	/
11	Water inlet connection	/
12.1	Electric heating tape	For the heating plate heat exchanger
12.2	Electric heating tape	For the expansion vessel heating connection pipe

HEAT PUMPS

Air-water heat pumps

DIAGRAM OF FLOW RATE – HEAD – LOAD LOSS

The pump speed can be selected by adjusting the red knob on the pump. The point indicated by the notch indicates the pump speed. The default setting is maximum speed (C3). If the water flow in the system is too high, the speed can be set to low (C1). The external static pressure function available for the water flow is shown in the graph below.

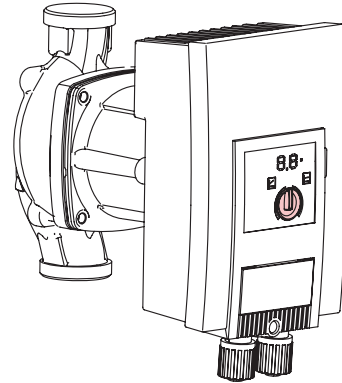

	Model	UM	NXHM 018T	NXHM 022T	NXHM 026T	NXHM 030T
Available pump head (A7; W35) (1)		kPa	100	92	78	58
Minimum water flow rate		m ³ /h	1.62	1.62	1.62	1.62
Maximum water flow rate		m ³ /h	3.90	4.70	5.00	5.40

(1) Outdoor air temperature 7°C BS, 6°C BU; water inlet/outlet 30/35°C.

NXHM 018T-030T

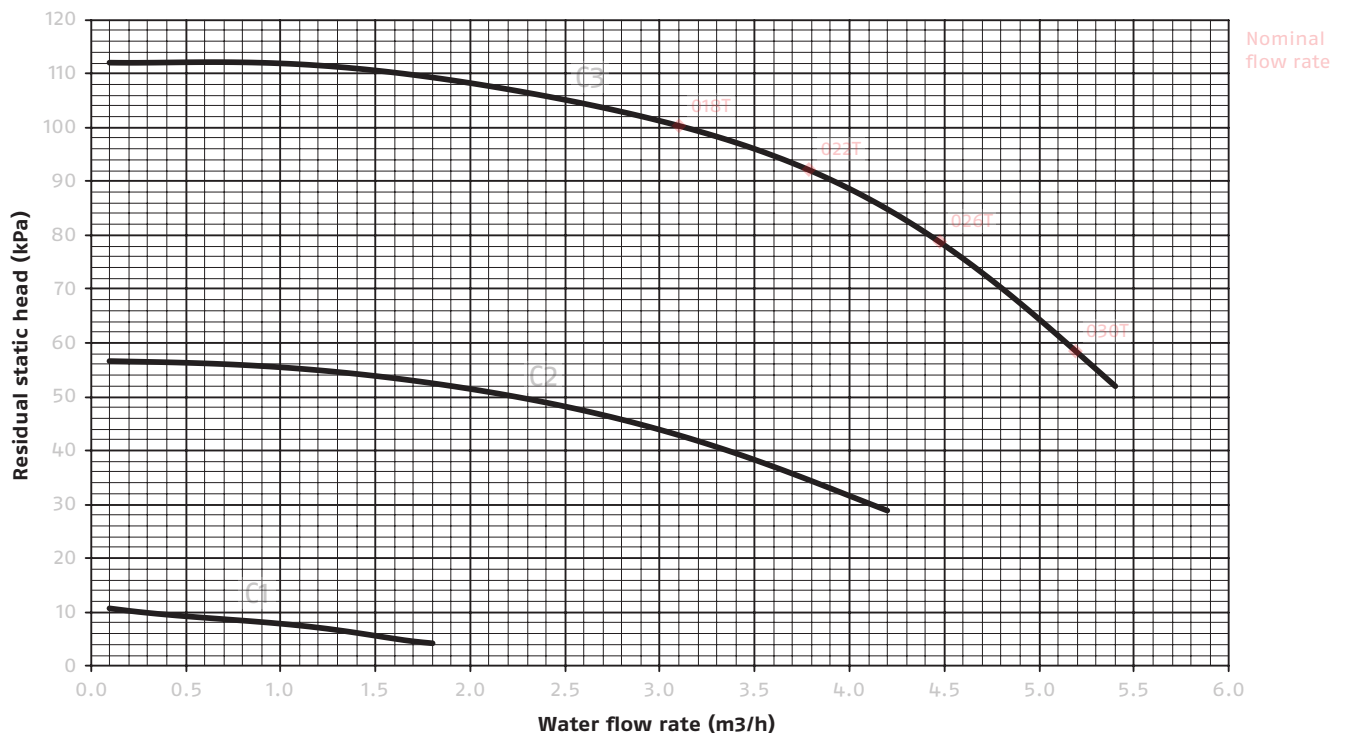

WATER IN THE HEATING SYSTEMS

CHEMICAL-PHYSICAL CHARACTERISTICS

The chemical-physical characteristics of the water must comply with European standard EN 14868 and the tables below:

System water reference values		
pH	-	7 - 8
Electrical conductivity	µS/cm	10 - 600
Chlorine ions	mg/l	< 10
Sulphuric acid ions	mg/l	< 30
Total iron	mg/l	< 5
Alkalinity M	mg/l	< 100
Total hardness	mmol/l	1 - 2.5
Sulphur ions	-	none
Ammonia ions	-	none
Silicon ions	mg/l	< 1

Well or groundwater not coming from the aqueduct should always be carefully analysed and if necessary conditioned with appropriate treatment systems.

If the initial water hardness exceeds the value indicated in the table, a water softening system must be used.

Excessive water softening (total hardness < 1.5 mmol/l) could lead to corrosion on contact with metal elements (pipes or boiler parts). The conductivity value must also be kept within 600 µS/cm.

Check the chloride concentration at the outlet after regeneration of the resins.

It is strictly prohibited to introduce acids into the washing circuit.

It is strictly prohibited to constantly or frequently top up the system, as this can damage the heat exchanger of the appliance.

SYSTEM WATER CONTENT AND FLOW RATE

Heat pumps require systems that guarantee a constant fluid flow rate to the device, within minimum and maximum values and with sufficient volumes to avoid any imbalance in the cooling circuits and ensure the correct degree of comfort.

SYSTEM WATER CONTENT

A minimum volume of water in the system's primary circuit must be guaranteed for the appliance to operate correctly.

The minimum volume is necessary to prevent the risk of ice formation during defrosting operations or continuous modulation of the compressor frequency.

It also provides the following advantages:

- less appliance wear;
- increase in system efficiency;
- improved stability and temperature precision.

Model	UM	NXHM 018T	NXHM 022T	NXHM 026T	NXHM 030T
Minimum system water content (1) (2)	l	40	40	40	40

(1) Excluding the volume of water inside the unit.

(2) In the case of cascade installation, the minimum volume should be $\geq 40 \text{ l} * n$ where n is the number of connected units.

HEAT PUMPS

Air-water heat pumps

ELECTRICAL CONNECTIONS

STANDARD WIRING COMPONENT SPECIFICATIONS

Panel 1: compressor compartment and electrical components: XT1.

POWER SUPPLY OF THE OUTDOOR UNIT (1)					
Model	UM	NXHM 018T	NXHM 022T	NXHM 026T	NXHM 030T
Maximum overcurrent protection (MOP)	A	18	21	24	28
Wiring size	mm ²	6	6	6	6

(1) The stated values are maximum values (see electrical data for exact values).
The default earth leakage circuit breaker must be a high-speed 30 mA (<0.1 s) switch.

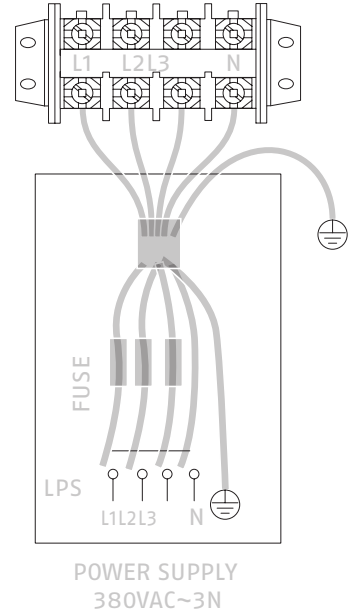

CONNECTION FOR PARALLEL SYSTEM (CASCADE)

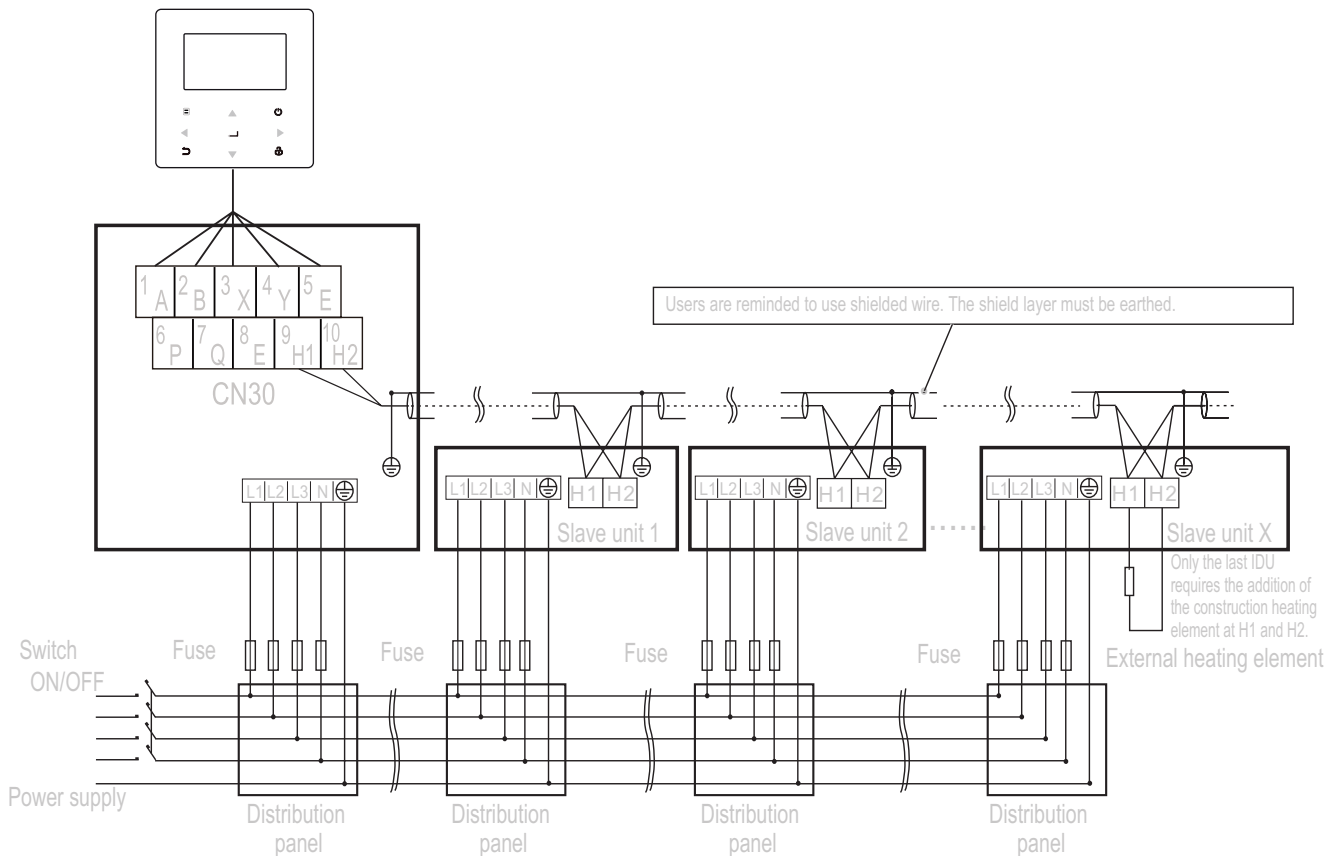

The parallel function of the system supports a maximum of 6 machines.
To ensure successful automatic addressing, all machines must be connected to the same power supply and which is evenly supplied.
Only the Master unit can connect the controller, the SW9 must be set to 'on' on the Master unit; the slave unit cannot connect the controller.
Users are reminded to use shielded wire. The shield layer must be earthed.

CONNECTIONS FOR OTHER COMPONENTS

For the electrical connections, please refer to the INSTALLER manual for the product.

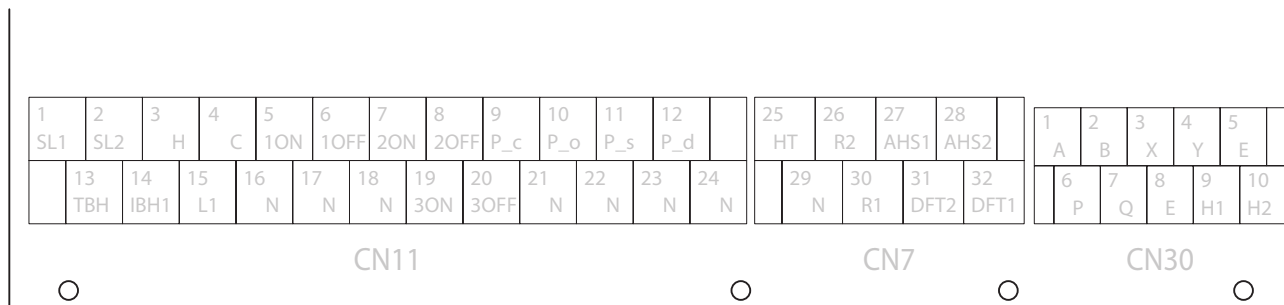

CODE	PRINT	CONNECTION A
1	1 SL1	Solar energy input signal
	2 SL2	
2	3 H	Room thermostat input (high voltage)
	4 C	
	15 L1	
3	5 1ON	SV1 (3-way valve)
	6 1OFF	
4	7 2ON	SV2 (3-way valve)
	8 2OFF	
5	9 P_c	Pump c (zone 2 pump)
	21 N	
6	10 P_o	External circulation pump / zone 1
	22 N	
7	11 P_s	Solar energy pump
	23 N	
8	12 P_d	DHW tube pump
	24 N	
9	13 TBH	Tank booster heater
	16 N	
10	14 IBH1	Internal backup heater 1
	17 N	
	18 N	
11	19 3ON	SV3 (3-way valve)
	20 3OFF	

CODE	PRINT	CONNECTION A
1	26 R2	Compressor operation
	30 R1	
	31 DFT2	
2	32 DFT1	Defrosting operation
	25 HT	
3	29 N	Anti-freeze heating element (external)
	27 AHS1	
3	28 AHS2	Additional heating source
	28 AHS2	

CODE	PRINT	CONNECTION A
1	1 A	Wired controller
	2 B	
	3 X	
	4 Y	
2	5 E	Outdoor unit
	6 P	
	7 Q	
3	8 E	Units connected in cascade
	9 H1	
	10 H2	

The port supplies the load with the control signal.

Two types of control signal port:

Type 1: Volt-free contact

Type 2: The port provides the signal with 220V voltage. If the load current is <0.2A, the load can connect directly to the port. If the load current is ≥0.2A, the AC contactor for the load must be connected.

HEAT PUMPS

Air-water heat pumps

CONTROL PANEL

The control panel is the interface for the installer and the user to carry out all operations to set the operating parameters and display the status of the components in the device.

Depending on the temperatures detected by the probes in the appliance and any probes installed in the domestic hot water tank, in the room and externally, the electronics modulate appliance operation, and the operating condition can be shown in the display.

Use the panel to set the required temperature for the system and for domestic hot water.

NXHM can be controlled via:

- Control panel
- External consents
- Modbus RTU

Control panel

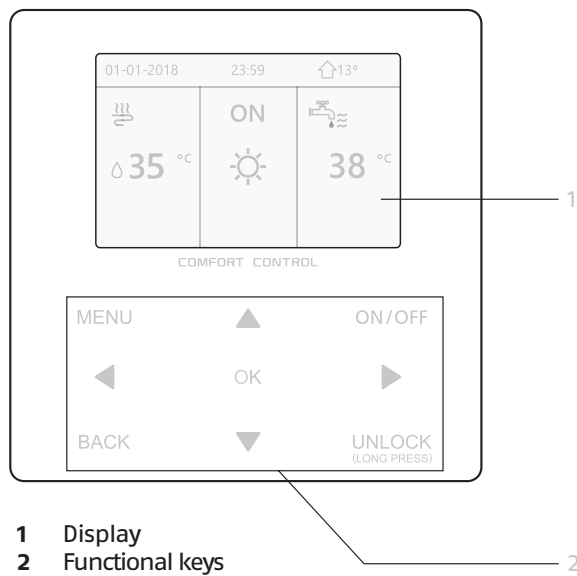

- 1 Display
- 2 Functional keys

Key	Description
MENU	Go to the menu structure (on the home page)
◀▶▲▼	Move the cursor on the display Move within the menu structure Adjust the settings
ON/OFF	Activate/ deactivate room heating /cooling operation or DHW mode Activate or deactivate functions in the menu structure
BACK	Go back to the next higher level
UNLOCK	Press and hold to unlock/lock the controller Unlock/lock certain functions such as 'DHW temperature control'.
OK	Go to the next step when setting a programming in the menu structure; confirm a selection to access a submenu in the menu structure

NXHM 018-030

PRODUCT DESCRIPTION FOR SPECIFICATIONS

External monobloc air-water heat pump, three-phase, with DC-inverter control and twin rotary compressor for all sizes to guarantee optimum dynamic balancing and reduce vibration, with continuous modulation from approx. 40% to 120%, designed to work with R32 refrigerant gas.

Given the wide operating range, it's ideal for every type of system, whether hybrid or monovalent. In heating mode in fact, it can supply water at 60°C with an outdoor temperature as low as -10°C, and in cooling mode water at 7°C with an outdoor temperature up to 46°C. It can also produce domestic hot water thanks to storage tanks and fixed coils or heat exchangers for instantaneous DHW production, as it can supply delivery water at 50°C with an outdoor temperature of 43°C.

Top level performance. Up to A+++ for low temperatures and A++ for medium temperatures in temperate zones, according to EN 14825_2016. All the performance values are certified by HP Keymark, MCS.

Built in accordance with the European eco-design regulations, which define the requirements for the ERP (Energy Related Products) standard in order to improve energy efficiency.

CHARACTERISTICS

- NXHM 018-030 provides an extremely high level of energy efficiency in both heating and cooling mode, thereby guaranteeing significant energy savings. The large, high-efficiency coils, together with the optimised circuits, ensure results that meet the European tax relief requisites. Efficiency levels in part load conditions (seasonal energy efficiency) are the highest in this industrial sector.
- Comfort throughout the year: the ground-breaking technology of NXHM means boosted comfort levels for users in terms of both water temperature control and quiet operation. The required temperature is reached quickly and kept constant, without any fluctuations. NXHM offers optimised, personalised comfort levels both in winter and in summer.
- NXHM can work in cooling mode even with low outdoor temperatures (from -5°C, and up to 43°C). To ensure the maximum comfort for the user, the units work in heating mode with outdoor temperatures down to -25°C, whereas in summer they can produce hot water up to 50°C for DHW applications, with the an outdoor temperature as high as 43°C.
- In the ambient comfort modes (both heating and cooling), weekly programming is a standard feature.
- In the DHW modes, weekly programming and an anti-legionella function - with thermal disinfection - are available as standard.
- A multitude of possible system layouts. Thanks to the sensors available as accessories, the unit can manage - for example - a solar system, one or two zones (one of them mixed) and DHW recirculation.
- Up to 6 units can be linked in a cascade. In cascade configurations, the master unit can be dedicated to DHW production.
- The unit can be connected to BMS systems using the Modbus protocol.
- USB port available for updating the electronic board software.
- A clean input is available, dedicated to smart grid functions.
- Operation guaranteed with at least 40lt of water in the system.

UNIT COMPONENTS

• STRUCTURE

Cabinet made of sheet steel painted with neutral-coloured powders (RAL 7044) to enhance resistance to corrosion caused by atmospheric agents. All the panels are removable.

• COMPRESSOR:

The dual compressor protection shield for sound insulation further reduces sound levels.

Advanced technology ensuring optimum energy efficiency and characterised by high output levels in peak conditions and optimised efficiency at low and medium compressor speeds.

The NXHM heat pump uses DC inverter technology that combines two electronic adjustment logics, pulse amplitude modulation (PAM) and pulse width modulation (PWM), to guarantee optimised compressor operation in all working conditions, minimise temperature fluctuation and ensure perfect comfort adjustment whilst at the same time considerably reducing energy consumption.

- PAM: modulation of the direct current pulse amplitude makes the compressor work in maximum load conditions (start-up and peak load) so as to increase the voltage in the case of a fixed frequency. The compressor works at high speed to quickly reach the required temperature.
- PWM: modulation of the direct current pulse width makes the compressor work in part load conditions, adapting the frequency in the case of a fixed voltage. The compressor speed is precisely adjusted and the system offers a high comfort level (no temperature fluctuations) in working conditions of outstanding efficiency.

The compressor frequency increases constantly until it reaches the maximum level. This ensures that there are no intensity peaks during the start-up phase, and also means a secure connection to the single-phase current supply even for high-output systems. This compressor start logic makes "soft start" starter devices unnecessary, while also guaranteeing that the maximum output is available immediately.

• EXTERNAL COIL:

The external coil is made of copper pipes and hydrophilic aluminium fins. This solution makes it easier for the water to move towards the bottom of the heat exchanger, by means of gravity.

In particular, this innovation means:

- frost takes longer to form, so it does not build up so much on the coil;
- the defrosting phase is more efficient thanks to improved water runoff on the fins which boosts operation in heating mode.

Blue Coating treatment is applied as standard to improve the resistance of the coils to corrosive agents, and is recommended in all applications where there is a moderate risk of corrosion.

• EXTERNAL FAN:

Single DC brushless fan motor with variable speed for optimum air distribution and extremely low noise levels. Two different maximum noise levels can be set.

HEAT PUMPS

Air-water heat pumps

- **ELECTRONIC EXPANSION VALVE:**

The electronic expansion valve is a dual-flow electronic expansion device whose job is to optimise the volume of the refrigerant fluid in the circuit and therefore the overheating issue, preventing the fluid from returning to the compressor. This device further boosts the high efficiency and reliability of the system as it enables it to work even with very low condensation pressure values across the whole operating range.

- **SOLENOID VALVE:**

Given the wide operating range of the unit, the solenoid valve (fully managed by the unit itself) allows the compressor to work at optimum temperature levels at all times.

- **PLATE HEAT EXCHANGER:**

Vertical plate heat exchanger in AISI 316 stainless steel.

- **BUILT-IN HYDRONIC UNIT:**

In domestic applications, the inertial storage tank can be connected directly underneath the unit to minimise the space taken up.

All the internal hydronic parts are insulated to reduce heat loss. The anti-freeze program contains special functions that use the heat pump and backup heater (if installed) to protect the whole system from the risk of freezing. When the water flow temperature in the system falls to a certain value, the unit heats the water using both the heat pump and the electric heating cock (and also the backup heater, if installed). The anti-freeze protection function is only deactivated when the temperature rises to a certain value.



RIELLO
Unit 7, Riverside Industrial Estate
Borderlake House
London Colney
St Albans
AL2 1HG
www.riello.com

The company is constantly striving to perfect its entire production range, so the design and size characteristics, technical data, equipment and accessories may vary.

RIELLO