

AUXG30KRLB

Please visit our [webstore](#) for full product and technical documentation 

Unit Type	Circular Flow Cassette	
Remote Controller	Option	
Nominal Cooling Capacity (kW)	8.5	
Nominal Heating Capacity (kW)	10.0	
Height (mm)	288	
Width (mm)	840	
Depth (mm)	840	
Weight (kg)	26	
Grille	UTGUKYAW	
Grille Dimensions (HxWxD) (mm)	53 x 950 x 950	
Grille Weight (kg)	6	
Airflow Rate - Cooling - High (m3/h)	1600	
Airflow Rate - Heating - High (m3/h)	1600	
Sound Pressure Level - Cooling - High (dB(A))	40	
Sound Pressure Level - Cooling - Low (dB(A))	33	
Sound Pressure Level - Heating - High (dB(A))	40	
Sound Pressure Level - Heating - Low (dB(A))	33	
Sound Power Level - Cooling - High (dB(A))	54	
Sound Power Level - Heating - High (dB(A))	54	
Moisture Removal (l/h)	2.5	
Refrigerant Type (Global Warming Potential)	R32 (675)	
Liquid Pipe Size	3/8"	
Gas Pipe Size	5/8"	
Unit Power Supply	From Outdoor Unit	



Document Downloads

- [Airflow - Fan Curve](#)
- [Controls & Accessories](#)
- [Dimensional Drawing](#)
- [Function Settings](#)
- [Inputs & Outputs](#)
- [Installation Manual](#)
- [Noise Curve](#)
- [Operation Manual](#)
- [Product Image](#)
- [Spare Parts List All Pages](#)
- [Specifications](#)
- [Wiring Diagram](#)

Related Items

- [AOYG30KATA](#) 8.5kW Economy Outdoor Unit - R32 Single Phase
- [AOYG30KBTB](#) 8.5kW Standard Outdoor Unit - R32 Single Phase
- [UTGUKYAW](#) 360 Cassette Grille Including Controller
- [UTYFYSXZ1](#) Wireless LAN interface
- [UTZVXRRA](#) Fresh Air Intake Kit for Cassette
- [UTYRCRYZ1](#) Compact Simple Remote controller
- [UTYRVNYM](#) LCD Wired Remote Controller
- [UTYRHRY](#) Simple Remote Controller (without Master Control)
- [UTYRSRY](#) Simple Remote Controller (with Master Control)
- [UTYRSNYM](#) Simplified Wired Remote Controller
- [UTYSHZXC](#) Human Sensor for Circular Flow Cassette
- [UTYTERX](#) External switch controller
- [FJRCWIFI1](#) IntesisHome Wireless LAN Adapter for Splits & VRF
- [UTYXCSX](#) External Input / Output PCB
- [UTZGXRA](#) External Input / output PCB Box
- [UTYLBTYC](#) Infra-Red Receiver Kit - 360 Cassettes
- [UTYXWZXZG](#) External Connect Kit
- [UTYVTGX](#) Splits Network Converter (DC Powered)
- [UTYVTGXV](#) Splits Network Converter (AC Powered)

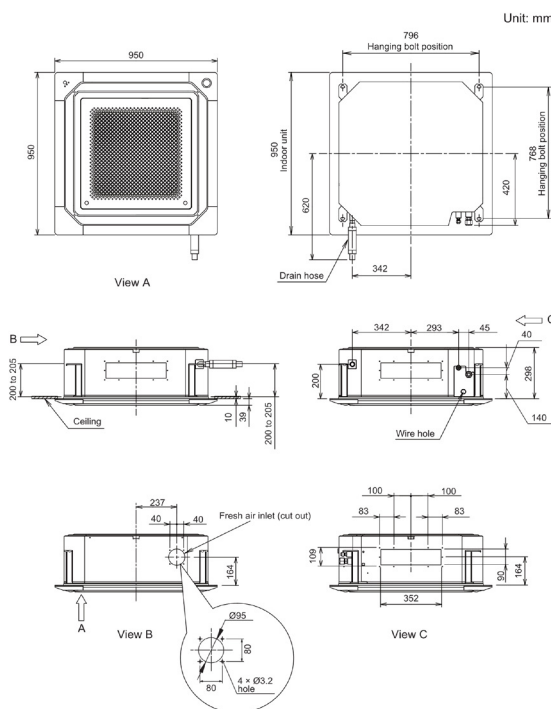

*Specifications and design are subject to change without notice for further improvement.
 *Actual products' colors may be different from the colors shown in this printed material.