

Compact air-air  
rooftop units

## **RPJ Series**

Air-air cooling units

## **IPJ Series**

Air-air heat pump units

TECHNICAL BROCHURE

**NA 18.757 C 07 - 2018**

# Vectios™ PJ



## Contents

Description.....	3
Range.....	3
Compliance.....	3
Model number nomenclature.....	4
Unit components.....	5
Factory options and accessories.....	7
Technical characteristics (EN-14511-2018).....	14
Overall dimensions of the different assemblies.....	16
Operation limits.....	17
Sound levels dB(A).....	17
Electrical connections.....	17
Cooling capacity (kW).....	18
Heating capacity (kW).....	20
Options for the outdoor unit.....	21
Options for the indoor unit.....	21
Pressure drops due to the indoor unit options.....	30
Dimensional drawings: RPJ series.....	31
Dimensional drawings: IPJ series.....	45
Centre of gravity and reactions in the supports: RPJ series.....	59
Centre of gravity and reactions in the supports: IPJ series.....	63
Recommended service clearance.....	67
Pre-assembly roofcurbs.....	69
Dimensional drawings with gas boiler.....	71
Weight overview of the various assemblies and the main options (kg).....	74



“  
 Integrated “plug&play” system  
 Eco-Design: *high seasonal efficiency*  
 Reliability with superior quality  
 Optimized dimensions and weights  
 Brand new *intelligent control* concept

Cooling capacity: 22,5 to 91,2 kW  
 Heating capacity: 22,0 to 90,1 kW



Cooling & heating



Heating recovery



Air filtration



Free cooling



Dehumidification



R410A

## DESCRIPTION

The **Vectios™ range** are compact, horizontal and autonomous air to air units, rooftop-type design. They are equipped with all the components required for the correct air conditioning to the installation.

- **RPJ series:** Units for **cooling** operation.
- **IPJ series:** Units for **reversible heat pump** operation.

The unit is connected directly to an air distribution ductwork without additional elements or equipment, pipes, cables, etc. taking up no floor space at all. This design reduces the cost of installation, facilities connections and ensures reliable operation.

The range of capacities of these units allows for the air conditioning of medium and large surface areas used for business or industry.

A vast number of options meet many operating requirements, such a:

- Recovery of the extracted air energy.
- Free-cooling.
- Air renewal.
- Indoor air quality control.
- Air filtration.
- Auxiliary devices for heating.
- Extension of operating limits for adaptation to extreme temperatures.

These units are equipped with electronic axial fans in the outdoor circuit, electronic plug-fans in the indoor circuit, air coils, hermetic scroll compressors and electronic control with microprocessor, optimized components for the refrigerant R-410A.

All of the units are tested and checked in the factory.

## RANGE

Vectios™ PJ models	Dimensions: L x W x H (mm)
0090 - 0120	2.225 x 1.750 x 1.230
0140 - 0160 - 0180 - 0190	2.225 x 1.750 x 1.230
0200 - 0220 - 0240	3.000 x 2.200 x 1.230
0280 - 0320 - 0360 - 0380	3.650 x 2.200 x 1.230

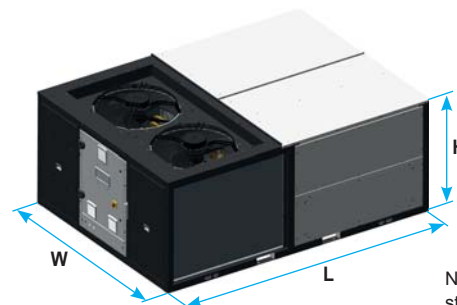

Note: Dimensions for the standard configuration.

## COMPLIANCE

- Machinery Directive 2006/42/EC (MD)
- Electromagnetic Compatibility Directive 2014/30/EU (EMC)
- Low Voltage Directive 2014/35/EU (LVD)
- Pressure Equipment Directive 2014/68/EU (Category 2) (PED)
- RoHS Directive 2011/65/EU (RoHS)
- Eco-design Directive 2009/125/EC (ECO-DESIGN)
- Energy Labelling Directive 2017/1369/EU (ECO-LABELLING)
- Harmonised Standard: EN 378-2:2012 (Refrigerating systems and heat pumps - Safety and environmental requirements).

## MODEL NUMBER NOMENCLATURE

IPJ_	0090	A	3	U	C0	AA	000	0	N	B	E	0	000	0000	0000	0	0	T100	00	P00	000	C100	0000	0000
1	2	3	4	5	6	7	8	9	10	11	12	13	14	15	16	17	18	19	20	21	22	23	24	25

### Group 1: Unit type

- RPJ: air/air cooling units
- IPJ: air/air heat pump

### Group 2: Unit model

- 1 circuit: 0090 / 0120 / 0140 / 0160 / 0180 / 0190
- 2 circuits: 200 / 0220 / 0240 / 0280 / 0320 / 0360 / 0380

### Group 3: Version of the series

### Group 4: Electrical power

- 3: 400V / 3ph + N / 50Hz
- 4: 400V / 3ph / 50Hz

### Group 5: Type of refrigerant

- U: R410A

### Group 6: Air flow + Assembly

- C0: Cross flow with standard assembly
- CS: Cross flow with 2 dampers
- CK: Cross flow with 3 dampers
- CA: Cross flow with axial return fan
- CP: Cross flow with lower return plug-fan
- CR: Cross flow with lower return plug-fan and active recovery
- CQ: Cross flow with upper return plug-fan or centrifugal fan
- CT: Cross flow with upper return plug-fan or centrifugal fan and active recovery
- CW: Cross flow with passive recovery
- T0: Tunnel flow with standard assembly
- TS: Tunnel flow with 2 dampers
- TP: Tunnel flow with return plug-fan
- TW: Tunnel flow with passive recovery

### Group 7: Coil coating : Outdoor - Indoor

- |                   |   |                 |
|-------------------|---|-----------------|
| AA — Outdoor coil | - | Indoor coil     |
| A: Aluminium      |   | A: Aluminium    |
| B: Polyurethane   |   | B: Polyurethane |
| C: Inera®         |   | C: Inera®       |
| D: Copper         |   | D: Copper       |
| E: Blygold®       |   | E: Blygold®     |

### Group 8: Heating

- 000: Without auxiliary heating
- G0x: Gas burner, 3 power outputs:  
x = Low (L) / Nominal (N) / High (H)
- G1x: Boiler + hot water coil, 3 power outputs:  
Low (L) / Nominal (N) / High (H)
- E0x: Electrical heaters, 3 power outputs:  
Low (L) / Nominal (N) / High (H)
- B0x: Hot water coil, 2 options:  
x = Standard (S) / Great cold (C)

### Group 9: Protection for low outdoor temperature

- 0: Without protection
- 1: Kit 1: Kit for outdoor temperature <-10°C
- 2: Kit 2: Kit for outdoor temperature <-14°C
- 3: Kit 3 : Kit 1 + Dampers with spring
- 4: Kit 4 : Kit 2 + Dampers with spring

### Group 10: Available pressure of the indoor fan

- N: 3 available pressures  
Low (L) / Nominal (N) / High (H)

### Group 11: Air filtration + stop-drop

- A: G4
- B: G4+ stop-drop
- C: G4 low pressure drop
- D: G4 low pressure drop + stop-drop
- E: G4 + M6

- F: G4 + M6 + stop-drop
- G: G4 + F7
- H: G4 + F7 + stop-drop
- I: G4 + F9
- J: G4 + F9 + stop-drop
- K: G4 l.p.d. + F7
- L: G4 l.p.d. + F7 + stop-drop
- M: G4 l.p.d. + F9
- N: G4 l.p.d. + F9 + stop-drop
- O: M6 + F7
- P: M6 + F7 + stop-drop
- Q: M6 + F9
- R: M6 + F9 + stop-drop
- S: F7 + F9
- T: F7 + F9 + stop-drop
- U: F9 + F9
- V: F9 + F9 + stop-drop

### Group 12: Type of outdoor fan

- A: AC (2-speed)
- E: EC (electronic)

### Group 13: Insulation

- 0: Standard insulation
- 1: Insulation Euroclass A2-s1, d0 (M0)

### Group 14: Indoor unit configuration

- 000 — Without optional accessories
  - └ A: Condensate drain pan in stainless steel
  - └ 1: Overpressure management
  - └ A: Clogged filters pressostat

### Group 15: Outdoor unit configuration

- 0000 — Without optional accessories
  - └ A: Unused
  - └ 1: Outdoor coil protective grille
  - └ A: Antivibration mounts
  - └ 1: Stop-drop at the fresh air intake

### Group 16: Passive recovery

- 0000 — Without optional accessories
  - └ 1: Filters G4
  - └ 2: Filters G4 low pressure drop
  - └ 3: Filters G4 + M6
  - └ A: Wheel speed with on/off control
  - └ B: Wheel speed with variable control
  - └ 1: Channel spacing of 2,0 mm
  - └ 2: Channel spacing of 2,5 mm
  - └ A: Material: Aluminium
  - └ B: Material: Aluminium with epoxy
  - └ C: Material: Hybrid wheel
  - └ D: Material: aluminium with silicagel

### Group 17: Extra heating

- 0: Without extra heating
- C: Heat recovery coil

### Group 18: Special applications

- 0: Without special applications
- Z: Air zoning
- L: Low return temperature application
- K: Zoning + Low temperature application

### Group 19: Sensors

- 0000 — Without options
  - └ H: Smoke detector sensor
  - └ A: Air quality sensor for environment
  - └ C: Air quality sensor duct-mounted
  - └ P: Air quality sensor on the pLAN network

- └ 1: 1 sensor RS485
- └ 2: 2 sensors RS485
- └ 3: 3 sensors RS485
- └ 4: 4 sensors RS485
- └ 5: 1 sensor NTC
- └ T: Ambient temperature sensor
- └ H: Ambient temperature+humidity sensor
- └ P: Ambient sensor on the pLAN network

### Group 20: Free-cooling + Outdoor humidity

- 00 — Without free-cooling + without sensor
  - └ 1: Outdoor humidity sensor on the unit
  - └ 2: Outdoor humidity sensor on pLAN network
  - └ T: Thermal free-cooling
  - └ M: Thermoenthalpic free-cooling
  - └ E: Enthalpic free-cooling

### Group 21: Terminal + Unit communication

- 000 — Without terminal + stand-alone + without card
  - └ M: Communication card RS485 Modbus/Carel
  - └ E: Communication card Ethernet PCoWeb
  - └ L: Communication card RS485 LonWorks®
  - └ B: Communication card Ethernet BACnet™
  - └ C: Communication card RS485 BACnet™
  - └ K: Communication card RS485 Konnex
  - └ 0: Free-standing unit
  - └ 1: Master unit
  - └ 2: Slave unit
  - └ P: VectigGD terminal in electrical cabinet
  - └ T: TCO user terminal in electrical cabinet
  - └ R: VectigGD terminal in electrical cabinet + TCO terminal remote up to 100 m
  - └ S: TCO terminal in electrical cabinet + VectigGD terminal remote up to 200 m
  - └ N: VectigGD terminal in electrical cabinet + VectigGD terminal remote up to 200 m

### Group 22: Miscellaneous item 1

- 000 — Without options
  - └ 1: Management of an on/off humidifier
  - └ 2: Management of a proportional humidifier
  - └ E: Energy meter
  - └ M: Energy meter and calculation of cooling and heating capacities
  - └ 1: Unused

### Group 23: Miscellaneous item 2

- C100 — Electrical switchgear + std phase relay
  - └ 1: Compressor soft starter
  - └ T: Tropicalization
  - └ 2: High performance phase monitoring relay
  - └ A: High performance switchgear

### Group 24: Centrifugal return fan

- 0000 — Without centrifugal return fan
  - └ 1: Low flow + nominal pressure
  - └ 2: Low flow + high pressure
  - └ 3: Nominal flow + nominal pressure
  - └ 4: Nominal flow + high pressure
  - └ 5: High flow + nominal pressure
  - └ 6: High flow + high pressure
  - └ Unused

### Group 25: Indoor air direction (coming soon)

- 0000 — Lower direction
  - └ 0: Lower supply and lower return
  - └ 1: Lateral supply and lower return
  - └ 2: Lower supply and lateral return
  - └ 3: Lateral supply and lateral return
  - └ Unused

## UNIT COMPONENTS

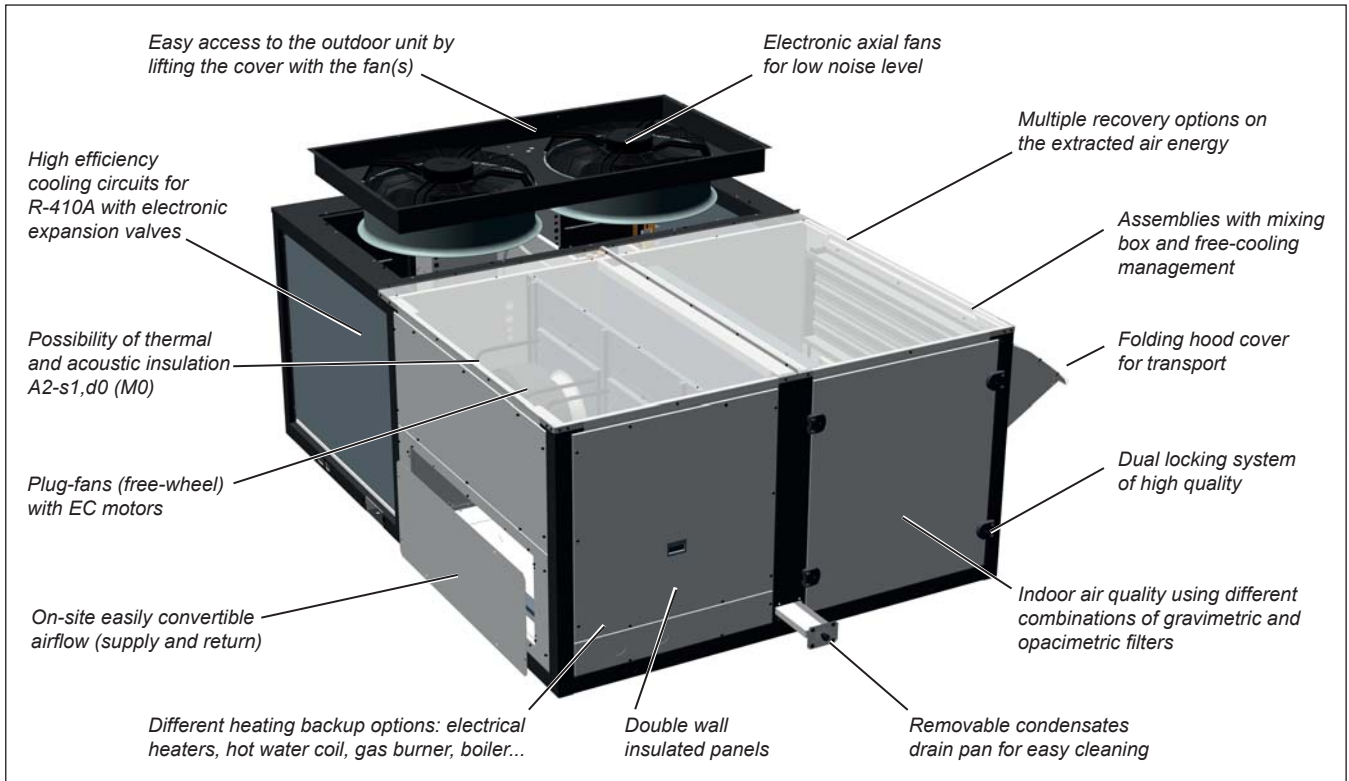

### Casing

- Casing made of galvanised steel metal with polyester paint, white colour RAL 7035 and graphite grey colour RAL 7024.
- New self-supporting frame that allow the transport of two stacked units and without the need for a wooden pallet.
- Removable panels for easy access to all components: electrical cabinet, compressors, fans, filters, etc.

### Outdoor unit

- Coil with copper pipes and aluminium fins.
- EC electronic axial fan(s) which adapt the rotation speed to the installation's requirements, thereby reducing electricity consumption, the sound level at partial charge and improving the unit's average seasonal efficiency.

The cover with the motor fan(s) may be lifted to access the inside of the outdoor unit.

### Indoor unit

- Thermal and acoustic insulation, in double wall panels and registers, with Euroclass A2-s1, d0 (M0) fire classification.
- Coil with copper pipes and aluminium fins.
- EC electronic supply plug-fans directly coupled with variable control speed and flow rate controller.

In tertiary sector installation, a high percentage of the annual air conditioning energy consumption comes from the use of fans for transporting air. Using fans which are more efficient has a direct impact on reducing consumption. Plug-fans with direct drive and variable speed offer the following advantages:

- Elimination of friction losses during transmission thanks to the

direct drive.

- Greater aeraulic efficiency of the rotor (reactive blades with an optimized profile), running at very high operating pressures.
- Greatly increased motor efficiency. Permanent magnets DC motors activated using electronic switching integrated into the motor itself.
- Variable speed to ensure a constant supply air flow rate, independent of the filters clogging level.
- Measuring the flow rate through a calibrated section at the fan intake and a differential pressure sensor allows the control to handle the flow rate reliably and precisely in both on CAV and VAV systems.
- Reusable gravimetric air filters G4, mounted on a frame. Dual locking system mounted on the access panel to filters.
- Removable and isolated condensates drain pan for easy cleaning.

### Cooling circuit

- Hermetic scroll-type compressors in tandem design that improves the management of stages and the part load efficiencies. Sound insulation, assembled over antivibration mounts. Control of phase equilibrium and the direction of rotation.
- Crankcase heater.
- Electronic expansion valve(s).
- Four-way cycle reversing valve(s) (heat pump units).
- Acid-resistant filter(s) dryer.
- Cooling design:
  - 1-air volume: IPJ models 0090 to 0190 and RPJ models.
  - 2-air volumes: IPJ models 0200 to 0380.



### Protections

- High pressure pressostat(s).
- High and low pressure transducers.
- Compressor discharge temperature control.
- Main door switch.
- Magnetohermic protection switches for the power line of compressors and fan motors.
- Automatic switch in the control circuit.

### Electrical cabinet

- Complete and fully wired electrical cabinet. Insulated access door to prevent condensation. Forced ventilation of the electrical cabinet. Protection IP54.
- Numeration of wired and identification of components in the electrical cabinet. It permits easy tracing and diagnostics.
- Hinges + quarter-turn latches on the removable access door.
- Electrical power supply with neutral.
- Main ground connection.
- Compressor and fan motor contacts.

### Vectic electronic control

The Vectic control consist of a control board, sensors, a graphic terminal, an user terminal (optional).

This system uses a RS485 field-bus to manage additional components. A BMS card (optional) allows the control board to be connected to a centralised technical management system.

It also manages a local connection between units through a pLAN network (Vectic Local Area Network), allowing data and information to be exchanged between units, for a maximum of 15 units.

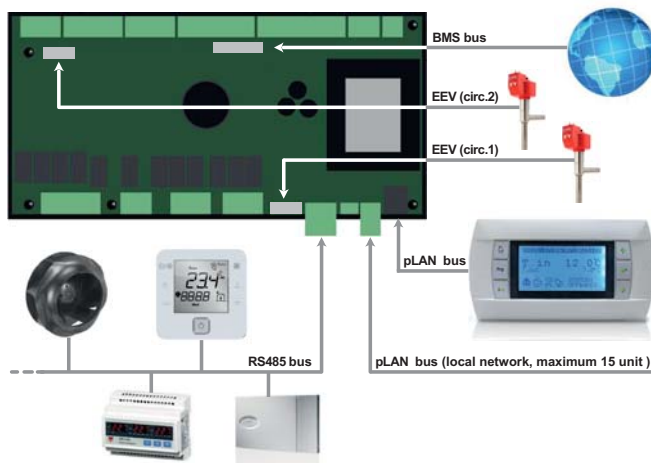

### Main functions:

- Selection of setpoint and operating mode: HEATING / COOLING / AUTO / VENTILATION.
- Continuous control of the operating parameters.
- Display of the values measured by the sensors.
- Compressors time delays.
- Defrosting management (heat pump units).
- Control of the supply air temperature.
- All-seasons operation via the condensation and evaporation pressure control.

The management of the unit in cooling mode is based on the principle of a high floating pressure. The condensation pressure setpoint is continually calculated depending on the outdoor temperature. This pressure is regulated by adjusting the air flow on the outdoor fans.

- Setpoint compensation based on the outdoor temperature.
- Hourly and weekly schedule.
- Fire protection.
- Diagnosis of faults and general alarm.

### Optional functions:

This control is used to manage addition components such as:

- External air damper for the renewal of fresh air, depending on the temperature of the mixed air or depending on the air quality sensor.
- Mixing box for thermal, enthalpic or thermoenthalpic free-cooling.
- Cooling circuit for the recovery of the extracted air energy.
- Rotary heat exchanger, with proportional or on/off control.
- Auxiliary electrical heaters: two-stage with on/off control or single-stage with proportional control.
- Hot water coil with 3-way valve, with proportional or on/off control.
- Gas burner with proportional control.
- Gas boiler with proportional control.
- Humidifier with proportional or on/off control.
- Clogged filter pressostat.
- Smoke detection station.
- Air quality sensor for measuring CO<sub>2</sub>.
- Energy meter and calculation of the cooling and heating capacities.
- Zoning of the air flow with dampers.
- Management of the low return temperature application.

### VecticGD graphic terminal:

This terminal, fitted as standard on the electrical cabinet, is very easy to use. It provides detailed explanations of control in easy to understand English. No decoding is required.



Only 6, large, easy-to-use buttons are required to maneuver through the entire menus.

This terminal is used to:

- Carry out initial programming of the unit.
- Modify operating parameters.
- Switch the unit ON / OFF.
- Select the operating mode and adjust the setpoints.
- Display the variables controlled and sensor values measured.
- Display the current alarms and their historical record.

### TCO user terminal (optional):

This terminal can be installed on the electrical cabinet, instead of the VecticGD graphic terminal. In this case, the remote connection of the VecticGD terminal is possible. Please consult the chapter "Options".

This terminal is used to:

- Switch the unit ON / OFF.
- Select the operating mode and adjust the setpoints.
- Display the installation's temperatures and humidity, outdoor temperature, supply air temperature, CO<sub>2</sub> sensor and opening of the outdoor damper.
- Display alarms codes.



## FACTORY OPTIONS AND ACCESSORIES

Family	Group	Description	Models	Installation in factory	Installation on site
Electrical power	4	400 V / 3 ph / 50 (without neutral)	All	✓	
Air flow + Assembly	6	CS: Cross flow with 2 dampers	All	✓	
		CK: Cross flow with 3 dampers	All	✓	
		CA: Cross flow with axial return fan	All	✓	
		CP: Cross flow with lower return plug-fan	All	✓	
		CR: Cross flow with lower return plug-fan and cooling recovery circuit (active recovery)	All	✓	
		CQ: Cross flow with upper return plug-fan or centrifugal fan	All	✓	
		CT: Cross flow with upper return plug-fan or centrifugal fan and cooling recovery circuit (active recovery)	All	✓	
		CW: Cross flow with rotary heat exchanger (passive recovery)	All	✓	
		TS: Tunnel flow with 2 dampers	0200 to 0380	✓	
		TP: Tunnel flow with return plug-fan	0200 to 0380	✓	
		TW: Tunnel flow with rotary heat exchanger (passive recovery)	0200 to 0380	✓	
Coil coating	7	Coil with copper pipes and copper fins	All	✓	
		Coil with copper pipes and fins of an aluminium alloy (INERA®)	All	✓	
		Coil with copper pipes and aluminium fins with polyurethane coating	All	✓	
		Blygold® coating	All	✓	
Heating	8	Auxiliary hot water coil : Standard or Great cold	All	✓	
		Auxiliary electrical heaters	All	✓	
		Natural or propane gas burner (supplied installed into a pre-assembly roofcurb)	All		✓
		Gas boiler + Auxiliary hot water coil	All	✓ (*)	
Protection low temperature	9	Kit 1: Antifreeze protection kit for low temperature (<-10°C)	All	✓	
		Kit 2: Antifreeze protection kit for low temperature (<-14°C)	All	✓	
		Kit 3: Kit 1 + Dampers with spring	All	✓	
		Kit 4: Kit 2 + Dampers with spring	All	✓	
Indoor fan	10	High available pressure of the indoor fan	All	✓	
		Low available pressure of the indoor fan	All	✓	
Air filtration + stop-drop	11	Stop-drop in the indoor air coil	All	✓	✓
		Gravimetric filters G4 with low pressure drop	All	✓	✓
		Gravimetric filters G4 + folded opacimetric filters M6, F7 or F9	All	✓	✓
		Gravimetric filters G4 low pressure drop + folded opacimetric filters F7 or F9	All	✓	✓
		Double stage of folded opacimetric filters (M6+F7, M6+F9, F7+F9 or F9+F9)	All	✓	✓
Outdoor fan	12	Axial 2-speed outdoor fan(s) directly coupled to the motor	All	✓	
Insulation	13	Ceramic fibre for thermal and acoustic insulation, Euroclass A2-s1, d0 (M0)	All	✓	
Indoor unit	14	Condensate drain pan in stainless steel	All	✓	✓
		Management of the overpressure	All	✓	
		Differential pressure switch to detect clogged filters	All	✓	
Outdoor unit	15	Outdoor coil protective grille	All	✓	✓
		Stop-drop at the fresh air intake	All	✓	✓
		Antivibration mounts made of rubber	All	✓	✓
Passive recov.	16	Rotary heat exchanger with CW and TW assemblies	All	✓	
Extra heating	17	Heat recovery coil	All	✓	
Special applications	18	Air zoning	All	✓	
		Low return temperature application	All	✓	
		Air zoning + Low return temperature application	All	✓	
Sensors	19	Ambient temperature sensor: one NTC sensor connected to the control board or 1 to 4 RS485 sensors	All	✓	✓
		Ambient temperature + humidity sensor: one to four sensors with RS485 communication	All	✓	✓
		CO <sub>2</sub> air quality sensor environment installed, duct-mounted or installed on a pLAN local network	All	✓	✓
		Smoke detecting station in accordance with the NF S 61-961 standard	All	✓	✓
Free-cooling + Outd. humidity	20	Type of free-cooling: thermal, enthalpic or thermoenthalpic	All	✓	✓
		Outdoor air humidity sensor: supplied with the unit or installed on a pLAN local network	All	✓	✓
Terminal + Unit communication	21	TCO terminal installed in the electrical cabinet	All	✓	✓
		VectiGD terminal installed in the electrical cabinet + TCO terminal remote up to 100m	All	✓	✓
		TCO terminal installed in the electrical cabinet + VectiGD terminal remote up to 200m	All	✓	✓
		VectiGD terminal installed in the electrical cabinet + VectiGD terminal remote up to 200m	All	✓	✓
		Unit configuration: stand-alone, master or slave	All	✓	✓
		Communication cards: RS485 Modbus/Carel; Ethernet PCoWeb; RS485 LonWorks®; Ethernet BACnet™; RS485 BACnet™; RS485 Konnex	All	✓	✓
Miscellaneous item 1	22	Management of an humidifier with proportional or on/off control	All	✓	
		Energy meter	All	✓	
		Energy meter and calculation of the cooling and heating capacities	All	✓	
Miscellaneous item 2	23	Compressor soft starter	All	✓	
		Tropicalised components on the electrical cabinet: control board, cards and terminals	All	✓	
		High performance phase monitoring relay	All	✓	
		High performance magnetothermic switches	All	✓	
Return fan	24	Centrifugal return fan (CQ and CT assemblies). 6 combinations of air flow and available pressure	All	✓	
Air direction (coming soon)	25	0: Lower supply and lower return; 1: Lateral supply and lower return 2: Lower supply and lateral return; 3: Lateral supply and lateral return	All	✓	
Roofcurb	--	Standardised pre-assembly roofcurbs with adjustable height	Cross flow		✓
		Adaptation roofcurbs for replacing units on site	Tunnel flow		✓

(\*) Part of this option must be intalled on-site.

**Assembly (Group 6) + Indoor air direction (Group 25)**

Assembly	Description	Air flow	Models	Indoor air direction			
				0 Lower supply Lower return	1 Lateral supply Lower return	2 Lower supply Lateral return	3 Lateral supply Lateral return
C0	Standard	Cross Flow	All				
CS	Fresh air damper, interlocked with return damper	Cross Flow	All				
CK	Fresh air damper and exhaust air damper	Cross Flow	All			X	X
CA	Axial return fan	Cross Flow	All			X	X
CP	Lower return EC plug-fan	Cross Flow	All			X	X
CR	Lower return EC plug-fan + cooling recovery circuit	Cross Flow	All			X	X
CQ	Return EC plug-fan or centrifugal fan in top box	Cross Flow	All	X	X		

I: air supply

R: air return

N: fresh air intake

E: air extraction



Assembly	Description	Air flow	Models	Indoor air direction			
				0 Lower supply Lower return	1 Lateral supply Lower return	2 Lower supply Lateral return	3 Lateral supply Lateral return
CT	Return EC plug-fan or centrifugal fan in top box + cooling recovery circuit	Cross Flow	All	X	X		
CW	Lower return EC plug-fan + rotary heat exchanger	Cross Flow	All			X	X
T0	Standard in Tunnel Flow	Tunnel Flow	0200 to 0380		X		X
TS	Fresh air damper, interlocked with return damper	Tunnel Flow	0200 to 0240		X		X
			0280 to 0380		X		X
TP	Lower return EC plug-fan	Tunnel Flow	0200 to 0240		X	X	X
			0280 to 0380		X	X	X
TW	Lower return EC plug-fan + rotary heat exchanger	Tunnel Flow	0200 to 0380		X	X	X

I: air supply

R: air return

N: fresh air intake

E: air extraction

## Electrical power (Group 4)

These units can be supplied for the following power supply voltages:

- 400 V / 3 ph + N / 50 Hz (standard)
- 400 V / 3 ph / 50 Hz (optional)

## Coils coating (Group 7)

- Coils with copper pipes and copper fins. Upon request.
- Coils with copper pipes and fins of an aluminium alloy (INERA®), of high performance and great resistance to the corrosion.
- Coils with copper pipes and aluminium fins with polyurethane coating.
- Blygold® coating.

Note: These coating can be applied to various coils (outdoor, indoor and hot water coil) according to the combinations available in our "Selection Software".

## Heating (Group 8)

The unit only can incorporate one of these heating elements:

- **Auxiliary electrical heaters**, with two power stages and on/off control, for assembly and connection inside the unit.

Up to 3 values of total power available for each model:

Vectios™ PJ	E0L (Low)	E0N (Nominal)	E0H (High)
0090 to 0120	12 kW	18 kW	unavailable
0140 to 0190	12 kW	18 kW	27 kW
0200 to 0380	18 kW	27 kW	36 kW

- **Auxiliary hot water coil**, with three-way valve and proportional control, for assembly inside the unit.

The unit incorporates an anti-freeze thermostat as safety system.

There are two configuration types available:

- Standard (B0S), the only safety system is the anti-freeze thermostat.
- Great Cold (B0C), with anti-freeze technology based on the water temperature. This protection is made up of a circulation pump and two sensors inserted in the input and the output of the coil.

Important: this option is mandatory for an outdoor temperature lower than -20°C WB. Consult for percentages of glycol water above 20%.

Note: on units with the "Great Cold" option, air supply only may be lateral (factory-configured).

- **Gas boiler + Auxiliary hot water coil.** Natural or propane gas boiler with modulating actuator, in accordance with the Gas Directive 2009/142/EC, mounted on the side of the unit.

The boiler is connected to the water circuit of the auxiliary coil.



Up to 3 values of total power available for each model:

Vectios™ PJ	G1L (Low)	G1N (Nominal)	G1H (High)
0090 to 0190	unavailable	Condexa PRO 40 (coming soon)	Condexa PRO 70
0200 to 0380	Condexa PRO 50 (coming soon)	Condexa PRO 70	Condexa PRO 100

- Natural or propane **gas burner** with modulating actuator, in accordance with the Gas Directive 2009/142/EC, installed inside a pre-assembly roofcurb.

Condensation boiler with premixing and modulation technology that allows outputs close to 109% with regard to the lower heating value (LCV).

Up to 3 values of total power available for each model:

Vectios™ PJ	G0L (Low)	G0N (Nominal)	G0H (High)
0090 to 0190	PCH020	PCH034	PCH045
0200 to 0240	unavailable	PCH065	PCH080
0280 to 0380	unavailable	PCH080	PCH105

Note: It's recommended to use the clogged filter pressostat (optional) in units with gas burner.



## Protection for low outdoor T (Group 9)

- Kit 1: Antifreeze protective kit (<-10°C). Mandatory for an outdoor temperature lower than -10°C WB.

- Electrical heater for protection of the components of the electrical cabinet.
- Compressor with protection for low temperature.

- Kit 2: Antifreeze protective kit (<-14°C). Mandatory for an outdoor temperature lower than -14°C WB.

In addition to the options of -10°C, this includes:

- Reinforced electrical heater for protection of the components of the electrical cabinet.
- Electrical heater for anti-freeze protection of dampers of the mixing box (if applicable).
- Protective kit of the gas burner for low temperature (if applicable).

- Kit 3: Kit 1 + Dampers of the mixing box with spring for automatic closing in case of a power failure.

- Kit 4: Kit 2 + Dampers of the mixing box with spring for automatic closing in case of a power failure.

### Available pressure of the indoor fan (Group 10)

- There are 3 optional fans depending on the available pressure:
    - Low pressure (L): all models except for 0280 and 0320.
    - Nominal pressure (N): all models.
    - High pressure (H): models 0200 to 0380.
- Important: our "Selection Software" will choose the supply fan with lower consumption for the available pressure required.

### Air filtration + stop-drop (Group 11)

Options to improve indoor air quality:

- Different combinations of filters are available:
  - G4 gravimetric filters with low pressure drop.
  - G4 gravimetric filters + M6, F7 or F9 folded opacimetric filters.
  - G4 gravimetric filters with low pressure drop + F7 or F9 folded opacimetric filters.
  - Dual-stage of folded opacimetric filters (M6+F7, M6+F9, F7+F9 or F9+F9).

Classification of our filters according to the new ISO 16890 Standard:

- G4 → ISO Coarse 60%
  - M6 → ISO ePM2.5 50%
  - F7 → ISO ePM1 60%
  - F9 → ISO ePM1 90%
- Stop-drop in the indoor air coil. Recommended in cases where a high moisture content in the air is foreseen or when the air flow is high.
- Note: with hot water coil it is not possible to assemble the stop-drop.

### Type of outdoor fan (Group 12)

- Axial 2-speed outdoor fan(s) directly coupled to the motor. Watertight motor class F, IP54 and internal thermal protection. Dynamically balanced propellers and outdoor protective grille.

### External insulation (Group 13)

- Ceramic panel for thermal and acoustic insulation, with Euroclass A2-s1, d0 (M0) fire classification.



Note: panels and registers of the indoor unit always include thermal and acoustic insulation, with Euroclass A2-s1, d0 (M0) fire classification.

### Indoor unit configuration (Group 14)

- Condensate drain pan in stainless steel for corrosion protection.
- Control of the overpressure (available in CP, CQ, CW, TP and TW assemblies). In installations with different air flow in supply and return, to prevent the entry of outside air or to eliminate odours from inside, the fresh air damper and the exhaust damper will be managed independently.
- Differential pressure switch to detect clogged filters as safety protection.

### Outdoor unit configuration (Group 15)

- Outdoor coil protective grille.
- Stop-drop at the fresh air intake. This stop-drop and the thermoenthalpic free-cooling are necessary in cases where a high moisture content in the air is foreseen.
- Antivibration mounts made of rubber.

### Passive recovery (Group 16)

- The rotary heat exchanger is fitted into a module placed on one side of the unit (assemblies CW and TW). This module is supplied disassembled with the unit, for installation on site.

This rotary recovery unit is used to transfer the sensible and latent heat from the air-conditioned room's return air to the fresh air used for ventilation, before it's discharged outdoors. This option reduces the compressors runtime, ensuring energy saving and benefiting the environment.

The efficiency of energy recovery depend on the wheel selected: material, wheel diameters, channel cross section and type of speed control.



### Extra heating (Group 17)

- Heat recovery coil (HRC). The coil function is to pre-heat the air that will pass through the main indoor coil. For this, it uses the temperature of an outdoor water installation.
- This option is compatible with C0, CS, CQ, CT, T0 and TS assemblies.

### Special applications (Group 18)

- Zoning of the air flow up to 4 different zones with a minimum air flow of 35 %. This function allows to adapt the indoor air flow to the requirements of the installation.
- Low return temperature application. This function allows to blow air with low temperature attending to the demands of the installation.

### Sensors (Group 19)

- Sensor(s) of ambient temperature. There are 3 options:
  - One NTC sensor connected to the control board.
    - Note: An ambient sensor with RS485 communication is required for installation at more than 30 meters.
  - One to four sensors with RS485 communication.
  - Sensor(s) installed on the master unit of the local network (pLAN).

- One to four sensors of ambient temperature + humidity, with RS485 communication or installed on the pLAN network. This sensor is compulsory in units with enthalpic or thermoenthalpic free-cooling (optional). In this case, the outdoor air humidity sensor is also added.
- Smoke detecting sensor. Smoke detecting station in accordance with the NF S 61-961 standard.
- Air quality sensor to enable measuring CO<sub>2</sub>. There are 3 options:
  - Sensor for installation in the environment.
  - Sensor duct-mounted (attached picture),
  - Sensor installed on the master unit of the local network (pLAN).



### Free-cooling + outdoor humidity (Group 20)

- Running the unit in free-cooling mode allows it to make best use of outdoor air conditions when these are more favourable than the return air conditions. This allows the cooling capacity to be reduced. The percentage of outdoor air can vary between 0% and 100%.

There are three options for free-cooling management:

- Thermal, by comparing the temperatures.
- Enthalpic, by comparing the enthalpies. Recommended in cases where a high moisture content in the air is foreseen.
- Thermoenthalpic, by comparing the enthalpies and correcting for temperature. This is the optimum solution as it takes the variability of the climate into account.

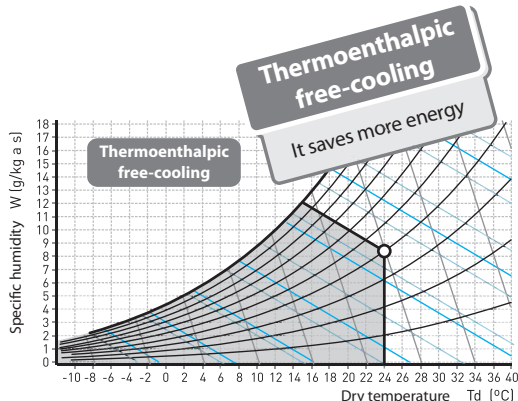
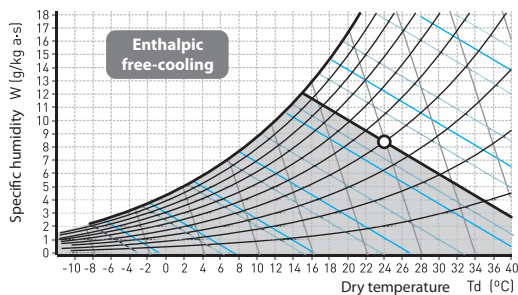
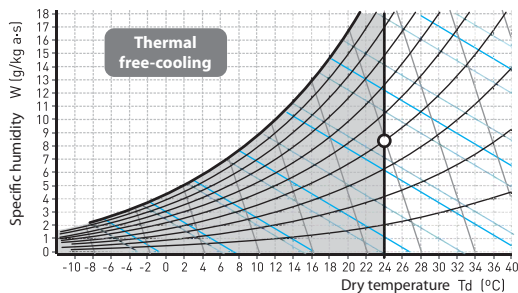

- Outdoor air humidity sensor (compulsory in units with optional enthalpic or thermoenthalpic free-cooling). There are 2 options:
  - Sensor supplied with the unit.
  - Sensor installed on another unit of the local network (pLAN).

### Terminal + unit communication (Group 21)

- By default, the electronic control Vectic is supplied with a graphic terminal installed in the electrical cabinet of the unit, but these other configurations also are available:



VecticGD graphic terminal



TCO user terminal

- TCO user terminal installed in the electrical cabinet, instead of the VecticGD graphic terminal.
- VecticGD graphic terminal installed in the electrical cabinet and TCO user terminal remote up to 100 meters.
- TCO user terminal installed in the electrical cabinet and VecticGD graphic terminal remote up to 200 meters (two TCONN bypass cards must be used from 50 to 200 meters).
- VecticGD terminal installed in the electrical cabinet and VecticGD terminal remote up to 200 meters (two TCONN bypass cards must be used from 50 to 200 meters).
- Control without terminal (for units with shared terminal in a pLAN network).
- By default, the electronic control is configured for a stand-alone unit, but it is also possible to place it in a pLAN network (μPC MEDIUM Local Area Network) as Master or Slave.

- This control allows the connection to a centralised technical management system by using a specific BMS card for some of the following communication protocols:

- RS485 serial cards for network communication with protocols: Carel, Modbus, LonWorks®, BACnet™ MSTP, Konnex.
- Ethernet pCO Web card for network communication with protocols: Modbus TCP/IP, BACnet™ Ethernet, TCP/IP, SNMP V1-2-3, FTP and HTTP.

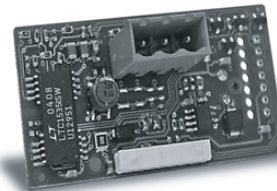

RS485 Carel/Modbus card



Ethernet pCO Web card

### Supervision solutions

Different solutions of supervision are available bases on the dimensions of the installation for unit fitted with Ethernet pCO Web and RS485 Carel / Modbus cards.

- **pCO Web**

It is the solution for the management and supervision of a single unit if this incorporates the Ethernet pCO Web card.

• **PlantWatchPRO3**

This is a solution designed for the monitoring of small and medium-size installations, capable of manage up to 30 units. Suitable for technical environments, no parts are in movement. It's available in two versions: panel and wall.

Includes: 7 " touch display, buzzer for notifications, 1 USB port and 1 SD card slot for downloading reports, charge devices models and applying service packs.

For this option, each unit needs one RS485 Carel / Modbus board.

• **BOSS**

This is the solution for the management and supervision of air-conditioning installations with up to 300 units. Integrated Hotspot Wi-Fi. It offers advanced monitoring and maintenance functions and allows zones and groups to be created to simplify the management of the installation. It also allows energy meters to be integrated to monitor the installation electricity consumption.

BOSS is available in two versions:

- CPU device.
- CPU device, monitor, keyboard and screen.

For this option, each unit needs one RS485 Carel / Modbus board.

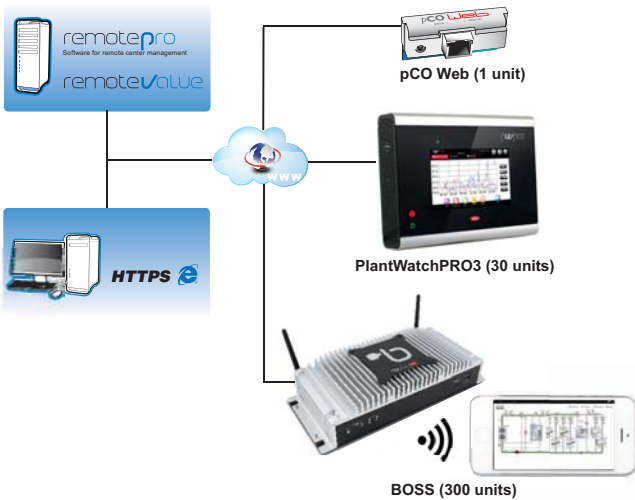

These systems are used to manage the installation remotely. All the information on the system can be accessed via a simple Internet connection. The online interface, the same one used by the local user, enables monitoring and complete configuration of the installation: from the office or anywhere else the user happens to be.

To control multiple sites remotely, there are special tools dedicated to centralized management, such as **RemotePRO** and **RemoteValue**.

**Miscellaneous item 1 (Group 22)**

- Management of an humidifier with proportional or on/off control.
- Energy meter for monitoring of the power consumption of the installation.
- Energy meter and calculation of the cooling and heating capacities. In addition to the energy meter, the unit incorporates mixing and supply enthalpic sensors with RS485 communication that enable cooling and heating capacities to be calculated.



**Miscellaneous item 2 (Group 23)**

- Compressor soft starter.
- High performance phase monitoring relay, which allows the protection settings to be adjusted (highly recommended for installations with power system voltage instability, lag between current and voltage, high level of electromagnetic disturbances EMC, etc.
- High performance electrical switchgear.
- Tropicalization: tropicalised components on the electrical cabinet with protective varnish: control board, cards and terminals.

**Centrifugal return fan (Group 24)**

- Centrifugal return fan, coupled by pulleys and belts. Electric motor with tensioner, class F, IP55 and internal thermal protection. Turbine with an impeller of front-curved blades. Greased spherical bearings, with no maintenance required.

Available in CQ and CT assemblies.

There are 6 fan options depending on the air flow and the available pressure:

- 1: Low flow + nominal pressure
- 2: Low flow + high pressure
- 3: Nominal flow + nominal pressure
- 4: Nominal flow + high pressure
- 5: High flow + nominal pressure
- 6: High flow + high pressure

**Pre-assembly roofcurbs**

- The "Cross flow" assemblies can rest on standardised pre-assembly roofcurbs with adjustable height, built in galvanised steel panelling with polyester paint and thermal insulation.

The levelling system uses angle pieces that allow adjustments in the X and Y axes.



- The "Tunnel flow" assemblies have a wide range of adaptation roofcurbs which are ready for the replacement on site of existing units from different manufacturers (upon request).

## TECHNICAL CHARACTERISTICS (EN-14511-2018)

RPJ series		0090	0120	0140	0160	0180	0190	0200	0220	0240	0280	0320	0360	0380
Cooling capacities	Cooling capacity ① (kW)	23,00	29,01	34,98	38,96	43,58	45,21	50,10	54,50	60,20	69,06	73,15	81,26	90,85
	Power input ② (kW)	7,17	9,34	10,65	12,14	14,15	14,92	15,61	17,30	20,00	21,51	22,93	26,38	30,18
	EER performance	3,21	3,11	3,28	3,21	3,08	3,03	3,21	3,15	3,01	3,21	3,19	3,08	3,01
	SEER	4,92	4,89	4,60	4,46	4,34	4,33	4,66	4,58	4,50	4,51	4,50	4,32	4,26
	ηs	194%	193%	181%	175%	171%	170%	183%	180%	177%	177%	177%	170%	167%
Outdoor circuit fan	Nominal air flow (m³/h)	9.000	14.500	17.000	17.000	17.000	17.750	31.000	31.000	31.000	33.000	33.000	34.500	35.000
	Available static pressure (mm.w.c)	5												
	Type	Electronic axial fan												
	Number / Diameter (mm)	1 / 630		1 / 800				2 / 800						
	Motor output (kW)	0,9		2,6				2 x 2,6						
	Maximum speed (r.p.m.)	1.140		1.020				1.020						
	Maximum absorbed current (A)	1,6		3,9				7,8						
Indoor circuit supply fan	Nominal air flow (m³/h)	5.100	6.500	8.500	8.750	9.000	9.000	12.000	12.500	12.500	15.500	15.500	16.000	16.000
	Available static pressure (mm.w.c)	12	12	12	15	15	15	20	20	20	20	20	20	25
	Type	Electronic plug-fan												
	Number / Diameter (mm)	1 / 500		1 / 500				2 / 500				2 / 500		
	Motor output (kW)	1 x 2,65		1 x 2,83				2 x 2,65				2 x 2,83		
	Power input (kW)	0,62	1,01	1,79	1,90	2,00	2,04	2,04	2,20	2,20	3,53	3,53	3,42	3,75
	Speed (r.p.m.)	1.700												
Maximum absorbed current (A)	4,2		4,3				8,4				8,6			
Compressor	Type	Scroll												
	No. compressors / stages / circuits	2 / 2 / 1												
	Oil type	Copeland 3MAF 32cST, Danfoss POE 160SZ, ICI Emkarate RL 32CF, Mobil EAL Artic 22CC												
	Volume of oil (l)	2,5	2,5	3,3	3,5	3,5	3,5	3,6	5,0	5,0	5,0	6,5	6,8	6,8
Electrical characteristics	Mains voltage	400 V / III ph / 50 Hz (±10%)												
	Power supply	3 Wires + Ground + Neutral												
	Maximum absorbed current (A)	18,9	26,5	26,4	29,9	33,6	34,0	42,6	49,0	53,5	54,6	55,7	61,3	74,3
Refrigerant	Type	R-410A												
	Global warming potential (GWP) ③	2.088												
	Charge (kg)	8,0	8,3	11,0	11,0	11,3	11,6	9,7	9,7	10,0	17,0	17,5	17,5	18,0
	Environment impact (tCO2eq)	16,7	17,3	23,0	23,0	23,6	24,2	20,3	20,3	20,9	35,5	36,5	36,5	37,6
Weight	C0 assembly (kg)	594	617	699	698	704	701	914	929	936	1.035	1.059	1.057	1.078

① Cooling capacity calculated in accordance with the EN-14511-2018 standard given for indoor temperature conditions 27°C, 19°C WB and 35°C outdoor temperature.

② Total power input by compressors and motorised fans under nominal conditions, calculated in accordance with the EN-14511-2018 standard.

③ Climatic warming potential of a kilogram of fluorinated greenhouse gas in relation to a kilogram of carbon dioxide over a period of 100 years.

## TECHNICAL CHARACTERISTICS (EN-14511-2018)

IPJ series		0090	0120	0140	0160	0180	0190	0200	0220	0240	0280	0320	0360	0380	
Cooling capacities	Cooling capacity ① (kW)	22,51	28,04	33,83	37,32	41,97	44,42	53,71	58,34	60,95	69,04	73,04	81,58	91,20	
	Power input ③ (kW)	7,04	9,03	10,30	11,84	13,47	14,33	16,62	18,47	19,47	21,36	23,00	25,89	29,08	
	EER performance	3,20	3,11	3,28	3,15	3,12	3,10	3,23	3,16	3,13	3,23	3,18	3,15	3,14	
	SEER	4,91	4,89	4,60	4,46	4,35	4,40	4,83	4,85	4,90	4,66	4,57	4,47	4,47	
	ηs	193%	193%	181%	175%	171%	173%	190%	191%	193%	183%	180%	176%	176%	
Heating capacities	Heating capacity ② (kW)	21,99	27,86	33,21	36,79	42,03	44,78	50,96	56,07	58,86	68,01	72,12	80,77	90,10	
	Power input ③ (kW)	5,80	7,96	9,06	10,17	11,95	12,90	14,38	15,95	16,82	18,90	20,19	22,82	25,79	
	COP performance	3,79	3,50	3,67	3,62	3,52	3,47	3,54	3,51	3,50	3,60	3,57	3,54	3,49	
	SCOP	3,48	3,45	3,45	3,45	3,47	3,45	3,60	3,68	3,50	3,43	3,59	3,56	3,58	
	ηs	136%	135%	135%	135%	136%	135%	141%	144%	137%	134%	140%	140%	140%	
Outdoor circuit fan	Nominal air flow (m³/h)	9.000	14.500	17.000	17.000	17.000	17.750	31.000	31.000	31.000	33.000	33.000	34.500	35.000	
	Available static pressure (mm.w.c)	5													
	Type	Electronic axial fan													
	Number / Diameter (mm)	1 / 630	1 / 800					2 / 800							
	Motor output (kW)	0,9	2,6					2 x 2,6							
	Maximum speed (r.p.m.)	1.140	1.020					1.020							
	Maximum absorbed current (A)	1,6	3,9					7,8							
Indoor circuit supply fan	Nominal air flow (m³/h)	5.100	6.500	8.500	8.750	9.000	9.000	12.000	12.500	12.500	15.500	15.500	16.000	16.000	
	Available static pressure (mm.w.c)	12	12	12	15	15	15	20	20	20	20	20	20	25	
	Type	Electronic plug-fan													
	Number / Diameter (mm)	1 / 500			1 / 500				2 / 500				2 / 500		
	Motor output (kW)	1 x 2,65			1 x 2,83				2 x 2,65				2 x 2,83		
	Power input (kW)	0,62	1,01	1,79	1,90	2,00	2,04	2,04	2,20	2,20	3,53	3,53	3,42	3,75	
	Speed (r.p.m.)	1.700													
Maximum absorbed current (A)	4,2		4,3				8,4				8,6				
Compressor	Type	Scroll													
	No. compressors / stages / circuits	2 / 2 / 1						4 / 4 / 2							
	Oil type	Copeland 3MAF 32cST, Danfoss POE 160SZ, ICI Emkarate RL 32CF, Mobil EAL Artic 22CC													
	Volume of oil (l)	2,5	2,5	3,3	3,5	3,5	3,5	5,0	5,0	5,8	6,6	6,9	7,1	7,1	
Electrical characteristics	Mains voltage	400 V / III ph / 50 Hz (±10%)													
	Power supply	3 Wires + Ground + Neutral													
	Maximum absorbed current (A)	18,9	26,5	26,4	29,9	33,6	34,0	48,1	53,5	53,2	56,3	60,2	68,8	73,8	
Refrigerant	Type	R-410A													
	Global warming potential (GWP) ④	2.088													
	Charge (kg)	8,0	8,3	11,0	11,0	11,3	11,6	12,5	12,8	13,0	20,0	20,3	20,3	20,5	
	Environment impact (tCO2eq)	16,7	17,3	23,0	23,0	23,6	24,2	26,1	26,7	27,1	41,8	42,4	42,4	42,8	
Weight	C0 assembly (kg)	585	610	675	680	685	690	990	995	1.040	1.155	1.160	1.165	1.170	

① Cooling capacity calculated in accordance with the EN-14511-2018 standard given for indoor temperature conditions 27°C, 19°C WB and 35°C outdoor temperature.

② Heating capacity calculated in accordance with the EN-14511-2018 standard given for indoor temperature conditions 20°C and 6°C WB outdoor temperature.

③ Total power input by compressors and motorised fans under nominal conditions, calculated in accordance with the EN-14511-2018 standard.

④ Climatic warming potential of a kilogram of fluorinated greenhouse gas in relation to a kilogram of carbon dioxide over a period of 100 years.

**OVERALL DIMENSIONS OF THE DIFFERENT ASSEMBLIES**

**Cross flow**

Vectios™ PJ	C0 and CS assemblies			CK, CA, CP and CR assemblies			CW assembly			CQ and CT assemblies		
	Length (mm)	Width (mm)	Height (mm)	Length (mm)	Width (mm)	Height (mm)	Length (mm)	Width (mm)	Height (mm)	Length (mm)	Width (mm)	Height (mm)
0090	2.225	1.750	1.230	2.230	1.755	1.905	2.230	2.565	1.905	2.230	1.760	1.975
0120	2.225	1.750	1.230	2.230	1.755	1.905	2.230	2.565	1.905	2.230	1.760	1.975
0140	2.225	1.750	1.230	2.230	1.755	1.905	2.230	2.565	1.905	2.230	1.760	1.975
0160	2.225	1.750	1.230	2.230	1.755	1.905	2.230	2.565	1.905	2.230	1.760	1.975
0180	2.225	1.750	1.230	2.230	1.755	1.905	2.230	2.565	1.905	2.230	1.760	1.975
0190	2.225	1.750	1.230	2.230	1.755	1.905	2.230	2.565	1.905	2.230	1.760	1.975
0200	3.000	2.200	1.230	3.000	2.205	1.905	3.000	3.015	1.905	3.000	2.210	1.995
0220	3.000	2.200	1.230	3.000	2.205	1.905	3.000	3.015	1.905	3.000	2.210	1.995
0240	3.000	2.200	1.230	3.000	2.205	1.905	3.000	3.015	1.905	3.000	2.210	1.995
0280	3.650	2.200	1.230	3.655	2.205	1.905	3.655	3.015	1.905	3.655	2.210	1.995
0320	3.650	2.200	1.230	3.655	2.205	1.905	3.655	3.015	1.905	3.655	2.210	1.995
0360	3.650	2.200	1.230	3.655	2.205	1.905	3.655	3.015	1.905	3.655	2.210	1.995
0380	3.650	2.200	1.230	3.655	2.205	1.905	3.655	3.015	1.905	3.655	2.210	1.995

**Tunnel flow**

Vectios™ PJ	T0 and TS assemblies			TP assembly			TW assembly		
	Length (mm)	Width (mm)	Height (mm)	Length (mm)	Width (mm)	Height (mm)	Length (mm)	Width (mm)	Height (mm)
0200	3.000	2.200	1.230	3.865	2.200	1.230	4.675	2.210	1.905
0220	3.000	2.200	1.230	3.865	2.200	1.230	4.675	2.210	1.905
0240	3.000	2.200	1.230	3.865	2.200	1.230	4.675	2.210	1.905
0280	3.650	2.200	1.230	3.655	2.210	1.905	4.465	2.210	1.905
0320	3.650	2.200	1.230	3.655	2.210	1.905	4.465	2.210	1.905
0360	3.650	2.200	1.230	3.655	2.210	1.905	4.465	2.210	1.905
0380	3.650	2.200	1.230	3.655	2.210	1.905	4.465	2.210	1.905



*Cross flow (all models)*



*Tunnel flow (models 0200 to 0380)*



## OPERATION LIMITS

Inlet air conditions		Cooling		Heating
		RPJ	IPJ	IPJ
Indoor coil	Minimum	13°C BH		10°C
	Maximum	24°C BH		27°C
Outdoor coil	Minimum	12°C ①		-15°C BH ②
	Maximum	52°C	48°C	15°C BH

① With a condensation pressure control operating down to -10°C.

② When the outdoor temperature is usually below 5°C WB, the installation of a support element is recommended.

## SOUND LEVELS dB(A)

### Sound power level (LW)

Vectios™ PJ	0090	0120	0140	0160	0180	0190	0200	0220	0240	0280	0320	0360	0380
63 Hz	55,2	60,8	61,4	60,9	61,3	63,1	64,3	64,5	64,9	64,8	64,6	64,6	65,3
125 Hz	64,2	66,7	68,9	66,1	70,0	71,1	69,6	69,9	71,5	72,4	71,3	71,4	74,0
250 Hz	71,8	74,8	76,1	72,9	76,3	76,4	77,0	77,7	78,9	79,7	78,4	77,9	79,3
500 Hz	70,2	76,7	76,4	76,8	77,1	78,3	79,5	80,1	80,4	79,9	80,1	80,2	80,9
1000 Hz	72,0	76,2	76,3	77,5	77,3	78,2	79,4	79,9	80,2	79,8	80,4	80,6	80,7
2000 Hz	69,7	73,5	74,3	75,3	74,1	75,5	77,0	77,4	77,8	77,7	78,3	78,1	77,7
4000 Hz	62,6	69,2	70,3	70,6	70,4	72,2	73,1	73,4	73,7	73,8	73,9	74,2	74,4
8000 Hz	59,0	63,7	65,5	65,8	65,6	67,5	67,9	68,2	68,6	68,9	69,1	69,4	69,6
Total dB(A)	77,5	82,0	82,5	82,5	83,0	84,0	85,0	85,5	86,0	86,0	86,0	86,0	86,5

### Sound pressure level (LP)

Measurement conditions: in a clear field, measured at a distance of 5 metres, directivity 2 and at 1,5 metres from the ground.

Vectios™ PJ	0090	0120	0140	0160	0180	0190	0200	0220	0240	0280	0320	0360	0380
Total dB(A)	51,0	55,5	56,0	56,0	56,5	57,5	58,3	58,8	59,3	59,3	59,1	59,1	59,6

Note: The sound pressure level depends on the installation conditions and, as such, it only indicated as a guide. Values obtained according to the ISO 3744 standard.

## ELECTRICAL CONNECTIONS

No.	Vectios™ PJ		0090 to 0380
1	Main power supply	400 III (±10%)	3 Wires + Ground + Neutral
2	Remote connection of graphic terminal (by default installed on the electrical cabinet) ①		telephone cable 6 wires standard (RJ12 connector)
4	Remote off/on (optional)		2 wires
5	General fault signal (optional)		2 wires
6	Circulation pump signal for HWC (antifreeze sec.) (opt.)		1 wire
7	Ambient sensor	NTC	2 wires
8		RS485	5 wires ②
9	Air quality sensor (optional)		3 wires

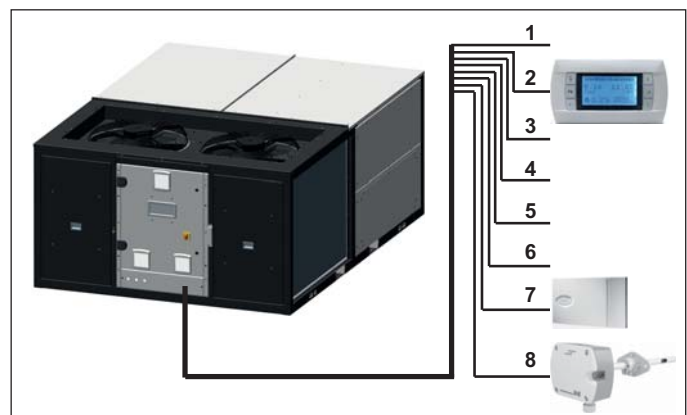

① In this case, it's possible to install the user terminal on the electrical cabinet.

② Up to four RS485 ambient sensors can be connected in series on the field-bus of the control board.



**COOLING CAPACITY (kW)**

**Outdoor temperature 35°C**

RPJ series	Flow (m³/h)	Indoor air temperature																							
		15°C / 50% HR			20°C / 50% HR			23°C / 50% HR			25°C / 50% HR			27°C / 50% HR			29°C / 50% HR			31°C / 50% HR					
		Pft	Pfs	Pa	Pft	Pfs	Pa	Pft	Pfs	Pa	Pft	Pfs	Pa	Pft	Pfs	Pa	Pft	Pfs	Pa	Pft	Pfs	Pa			
0090	4.080	16,4	15,1	5,9	19,0	16,0	6,0	20,5	16,5	6,1	21,5	16,8	6,2	22,6	17,2	6,2	23,7	17,4	6,3	24,9	17,7	6,4			
	5.100	17,0	16,8	5,9	19,6	17,9	6,1	21,1	18,5	6,2	22,2	19,0	6,2	23,3	19,3	6,3	24,5	19,7	6,4	25,6	20,0	6,4			
	6.120	17,5	18,3	5,9	20,1	19,6	6,1	21,6	20,4	6,2	22,7	20,9	6,3	23,8	21,4	6,3	25,0	21,8	6,4	26,1	22,3	6,5			
0120	5.200	21,0	19,3	7,3	24,2	20,4	7,4	26,1	21,1	7,5	27,4	21,5	7,6	28,7	21,9	7,7	30,1	22,2	7,7	31,6	22,6	7,8			
	6.500	21,7	21,5	7,3	25,0	22,8	7,5	27,0	23,6	7,6	28,3	24,1	7,6	29,6	24,6	7,7	31,1	25,1	7,8	32,5	25,5	7,8			
	7.800	22,4	23,3	7,3	25,7	24,9	7,5	27,6	25,9	7,6	28,9	26,6	7,7	30,3	27,2	7,7	31,7	27,7	7,8	33,1	28,3	7,9			
0140	6.800	25,2	23,8	8,3	29,3	25,3	8,3	31,7	26,2	8,3	33,3	26,8	8,3	35,1	27,3	8,3	36,9	27,8	8,3	38,8	28,3	8,3			
	8.500	26,1	26,4	8,3	30,3	28,2	8,3	32,7	29,4	8,3	34,4	30,1	8,3	36,2	30,8	8,3	38,0	31,5	8,3	40,0	32,1	8,3			
	10.200	26,8	28,2	8,3	31,1	30,6	8,3	33,5	32,2	8,3	35,2	33,1	8,3	37,0	34,0	8,3	38,8	34,8	8,3	40,8	35,6	8,3			
0160	7.000	28,4	25,9	9,1	32,8	27,3	9,3	35,4	28,2	9,5	37,2	28,8	9,6	39,0	29,3	9,7	41,0	29,8	9,8	42,9	30,2	9,9			
	8.750	29,4	28,7	9,2	33,9	30,5	9,4	36,5	31,6	9,5	38,3	32,3	9,6	40,2	33,0	9,7	42,2	33,6	9,8	44,2	34,2	10,0			
	10.500	30,3	31,0	9,2	34,8	33,2	9,4	37,4	34,6	9,6	39,2	35,5	9,7	41,1	36,3	9,8	43,1	37,1	9,9	45,1	37,8	10,0			
0180	7.200	31,6	28,1	10,3	36,6	29,6	10,7	39,4	30,5	10,9	41,4	31,1	11,1	43,5	31,6	11,2	45,6	32,0	11,4	48,0	32,5	11,6			
	9.000	32,8	31,0	10,4	37,8	32,8	10,8	40,8	34,0	11,0	42,8	34,7	11,2	44,9	35,4	11,4	47,1	36,0	11,5	49,5	36,6	11,7			
	10.800	33,7	33,7	10,5	38,8	35,9	10,9	41,8	37,3	11,1	43,8	38,0	11,3	46,0	38,9	11,4	48,3	39,7	11,6	50,6	40,4	11,8			
0190	7.200	32,9	28,7	11,0	38,0	30,1	11,3	41,0	31,0	11,5	43,0	31,5	11,7	45,1	32,0	11,8	47,3	32,5	11,9	49,6	32,9	12,1			
	9.000	34,3	31,7	11,1	39,4	33,4	11,4	42,4	34,5	11,6	44,5	35,1	11,8	46,6	35,8	11,9	48,9	36,4	12,0	51,2	36,9	12,2			
	10.800	35,2	34,4	11,2	40,5	36,4	11,5	43,5	37,7	11,7	45,6	38,5	11,8	47,8	39,3	12,0	50,0	40,0	12,1	52,4	40,7	12,2			
0200	9.600	35,7	33,1	11,3	41,4	35,1	11,6	44,6	36,4	11,8	46,9	37,2	11,9	49,3	38,0	12,0	51,8	38,7	12,1	54,4	39,4	12,3			
	12.000	37,0	36,3	11,4	42,8	39,0	11,7	46,1	40,7	11,9	48,5	41,7	12,0	51,0	42,8	12,1	53,5	43,7	12,2	56,1	44,6	12,4			
	14.400	38,0	39,1	11,5	43,9	42,4	11,8	47,3	44,6	11,9	49,7	45,8	12,1	52,1	47,1	12,2	54,7	48,2	12,3	57,3	49,2	12,4			
0220	10.000	38,8	34,9	12,6	45,0	37,0	13,0	48,5	38,3	13,2	51,0	39,1	13,4	53,6	39,9	13,6	56,3	40,7	13,7	59,1	41,3	13,9			
	12.500	40,4	38,7	12,7	46,7	41,2	13,1	50,3	42,9	13,4	52,9	43,9	13,5	55,5	44,8	13,7	58,2	45,7	13,9	61,1	46,5	14,1			
	15.000	41,5	41,7	12,8	47,9	44,8	13,2	51,6	46,9	13,4	54,1	48,0	13,6	56,8	49,2	13,8	59,6	50,4	14,0	62,5	51,5	14,2			
0240	10.000	42,9	37,4	14,8	49,5	39,4	15,3	53,4	40,7	15,6	56,1	41,5	15,8	58,9	42,2	16,0	61,9	42,9	16,3	64,9	43,5	16,5			
	12.500	44,8	41,2	14,9	51,6	43,7	15,4	55,6	45,3	15,8	58,3	46,2	16,0	61,2	47,2	16,2	64,2	48,0	16,4	67,3	48,9	16,7			
	15.000	46,1	44,7	15,0	53,1	47,7	15,6	57,0	49,5	15,9	59,9	50,8	16,1	62,9	51,9	16,3	65,9	52,9	16,6	69,0	54,0	16,8			
0280	12.400	50,3	46,4	15,4	58,1	49,0	15,9	62,6	50,6	16,2	65,8	51,7	16,3	69,0	52,6	16,5	72,4	53,5	16,8	76,0	54,4	17,0			
	15.500	52,0	51,3	15,5	60,0	54,5	16,0	64,6	56,6	16,3	67,9	57,9	16,5	71,1	59,0	16,7	74,6	60,2	16,9	78,2	61,3	17,1			
	18.600	53,6	55,5	15,6	61,5	59,5	16,1	66,1	62,1	16,4	69,3	63,6	16,6	72,6	65,1	16,8	76,1	66,6	17,0	79,8	67,7	17,2			
0320	12.400	53,2	47,9	16,7	61,3	50,4	17,2	66,0	52,1	17,5	69,3	53,0	17,7	72,7	53,9	17,9	76,4	54,8	18,2	80,2	55,6	18,4			
	15.500	55,1	52,8	16,8	63,5	56,0	17,4	68,3	58,0	17,7	71,7	59,3	17,9	75,2	60,4	18,1	78,9	61,6	18,3	82,6	62,6	18,6			
	18.600	56,5	57,2	16,9	65,0	61,1	17,4	69,9	63,5	17,8	73,3	65,1	18,0	76,9	66,6	18,2	80,6	68,0	18,5	84,6	69,4	18,7			
0360	12.800	59,1	52,0	19,2	68,0	54,5	19,9	73,1	56,1	20,3	76,7	57,1	20,6	80,5	58,0	20,9	84,4	58,9	21,2	88,4	59,6	21,5			
	16.000	61,5	57,3	19,4	70,6	60,4	20,1	75,7	62,4	20,5	79,4	63,7	20,8	83,2	64,8	21,1	87,2	65,9	21,4	91,3	66,9	21,8			
	19.200	63,1	62,0	19,5	72,3	65,8	20,2	77,7	68,3	20,7	81,4	69,7	21,0	85,2	71,2	21,2	89,2	72,5	21,6	93,4	73,8	21,9			
0380	12.800	65,7	56,0	22,7	75,5	58,4	23,5	81,1	59,9	24,0	85,0	60,9	24,4	89,2	61,8	24,7	93,5	62,6	25,0	98,1	63,3	25,4			
	16.000	68,3	61,3	22,9	78,5	64,4	23,8	84,4	66,4	24,3	88,3	67,6	24,6	92,7	68,7	24,9	97,0	69,7	25,3	101,6	70,7	25,7			
	19.200	70,6	66,5	23,1	80,8	70,1	24,0	86,7	72,4	24,4	90,7	73,8	24,8	95,0	75,2	25,2	99,4	76,5	25,5	104,1	77,7	26,0			

Pft: Total gross cooling capacity in kW  
 Pfs: Sensitive cooling capacity in kW  
 Pa: Compressor power input in kW

**Correction coefficients: variation of outdoor temperature and humidity**

Outdoor temp.	20°C	25°C	30°C	35°C	40°C	45°C	48°C	50°C	52°C	Relative humidity	40%	50%	60%	70%	80%	90%	Correction
Coefficient K1	1,161	1,111	1,045	1,000	0,939	0,874	0,845	0,815	0,797	Coefficient K4	0,962	1,000	1,045	1,089	1,133	1,176	<b>PFT = Pft x K1 x K4</b>
Coefficient K2	1,085	1,058	1,030	1,000	0,968	0,934	0,910	0,909	0,894	Coefficient K5	1,108	1,000	0,929	0,760	0,684	0,532	<b>PFS = Pfs x K2 x K5</b>
Coefficient K3	0,711	0,797	0,893	1,000	1,119	1,249	1,332	1,393	1,415	Coefficient K6	0,992	1,000	1,010	1,020	1,031	1,040	<b>PA = Pa x K3 x K6</b>

## COOLING CAPACITY (kW)

### Outdoor temperature 35°C

IPJ series	Flow (m³/h)	Indoor air temperature																				
		15°C / 50% HR			20°C / 50% HR			23°C / 50% HR			25°C / 50% HR			27°C / 50% HR			29°C / 50% HR			31°C / 50% HR		
		Pft	Pfs	Pa	Pft	Pfs	Pa	Pft	Pfs	Pa	Pft	Pfs	Pa	Pft	Pfs	Pa	Pft	Pfs	Pa	Pft	Pfs	Pa
0090	4.080	15,9	14,7	5,7	18,5	15,8	5,9	20,1	16,5	6,0	21,1	16,9	6,1	22,2	17,3	6,1	23,3	17,7	6,2	24,4	18,0	6,3
	5.100	16,6	16,4	5,8	19,2	17,7	5,9	20,7	18,6	6,0	21,8	19,1	6,1	22,9	19,6	6,2	24,0	20,0	6,2	25,1	20,5	6,3
	6.120	17,0	17,7	5,8	19,7	19,4	6,0	21,2	20,4	6,1	22,2	21,0	6,1	23,4	21,7	6,2	24,5	22,2	6,3	25,5	22,8	6,3
0120	5.200	20,5	19,5	7,0	23,6	20,4	7,2	25,4	21,0	7,2	26,6	21,4	7,3	27,9	21,7	7,4	29,2	22,0	7,4	30,5	22,1	7,5
	6.500	21,3	21,7	7,1	24,4	22,8	7,2	26,2	23,5	7,3	27,4	24,0	7,3	28,7	24,4	7,4	30,0	24,8	7,4	31,3	25,0	7,5
	7.800	21,8	23,3	7,1	24,9	24,8	7,2	26,7	25,9	7,3	28,0	26,4	7,4	29,3	27,0	7,4	30,6	27,5	7,5	31,9	27,8	7,5
0140	6.800	24,4	24,0	7,7	28,4	25,4	7,8	30,7	26,2	7,9	32,3	26,8	7,9	34,0	27,3	7,9	35,7	27,7	8,0	37,5	28,0	8,0
	8.500	25,4	26,6	7,8	29,4	28,3	7,9	31,7	29,5	7,9	33,3	30,1	8,0	35,0	30,8	8,0	36,8	31,4	8,0	38,5	31,7	8,1
	10.200	26,3	27,7	7,8	30,2	30,3	7,9	32,5	31,8	7,9	34,1	33,0	8,0	35,8	33,9	8,0	37,6	34,7	8,1	39,3	35,2	8,1
0160	7.000	27,5	26,1	8,9	31,7	27,3	9,1	34,1	28,0	9,2	35,7	28,5	9,3	37,5	29,0	9,4	39,3	29,3	9,5	41,1	29,6	9,6
	8.750	28,4	28,7	9,0	32,7	30,4	9,2	35,1	31,4	9,3	36,8	32,0	9,4	38,6	32,6	9,4	40,4	33,2	9,5	42,3	33,5	9,6
	10.500	29,2	30,8	9,0	33,5	32,9	9,2	36,0	34,4	9,3	37,7	35,1	9,4	39,5	36,0	9,5	41,3	36,6	9,6	43,1	37,1	9,7
0180	7.200	30,8	28,3	9,8	35,5	29,6	10,2	38,2	30,4	10,3	40,1	30,9	10,4	42,0	31,4	10,6	44,0	31,7	10,7	46,1	32,0	10,9
	9.000	31,9	31,3	9,9	36,7	32,9	10,2	39,4	33,9	10,4	41,4	34,6	10,5	43,4	35,2	10,7	45,4	35,7	10,8	47,5	36,0	11,0
	10.800	32,7	33,8	9,9	37,6	35,9	10,3	40,4	37,2	10,5	42,3	38,0	10,6	44,4	38,8	10,8	46,4	39,4	10,9	48,5	39,8	11,1
0190	7.200	32,7	29,4	10,5	37,6	30,6	10,8	40,4	31,4	11,0	42,3	31,8	11,1	44,4	32,3	11,3	46,5	32,6	11,4	48,5	32,8	11,5
	9.000	33,9	32,4	10,6	38,9	34,0	10,9	41,7	35,0	11,1	43,7	35,6	11,2	45,8	36,1	11,3	47,9	36,6	11,5	50,0	36,9	11,6
	10.800	34,9	35,1	10,7	39,9	37,0	11,0	42,8	38,3	11,2	44,8	39,0	11,3	46,9	39,7	11,4	49,0	40,4	11,5	51,1	40,7	11,7
0200	9.600	38,7	37,0	12,8	44,7	38,8	13,0	48,2	40,0	13,1	50,5	40,7	13,2	53,0	41,3	13,3	55,6	41,9	13,4	58,1	42,2	13,5
	12.000	40,1	40,9	12,8	46,2	43,2	13,1	49,7	44,8	13,2	52,1	45,6	13,3	54,6	46,5	13,4	57,2	47,2	13,5	59,7	47,6	13,6
	14.400	41,5	43,4	12,9	47,4	46,7	13,1	50,8	48,9	13,2	53,3	50,2	13,3	55,8	51,3	13,4	58,3	52,3	13,5	60,7	52,9	13,7
0220	10.000	42,4	39,7	14,4	48,7	41,4	14,7	52,4	42,6	14,8	55,0	43,3	14,9	57,6	44,0	15,0	60,3	44,5	15,1	63,0	44,8	15,3
	12.500	43,9	43,9	14,5	50,3	46,2	14,7	54,1	47,7	14,9	56,7	48,6	15,0	59,3	49,4	15,1	62,1	50,1	15,2	64,8	50,6	15,3
	15.000	45,1	47,7	14,5	51,5	50,5	14,8	55,3	52,4	14,9	57,9	53,5	15,1	60,6	54,4	15,2	63,4	55,5	15,3	66,1	56,1	15,4
0240	10.000	43,9	40,6	15,5	50,6	42,4	15,7	54,5	43,7	15,9	57,2	44,3	16,0	60,0	45,0	16,1	62,9	45,6	16,1	65,8	45,9	16,2
	12.500	45,6	45,0	15,6	52,4	47,3	15,8	56,4	48,8	15,9	59,1	49,6	16,0	61,9	50,5	16,1	64,9	51,3	16,2	67,8	51,7	16,3
	15.000	46,8	48,8	15,6	53,7	51,6	15,9	57,7	53,5	16,0	60,5	54,6	16,1	63,4	55,6	16,2	66,3	56,6	16,3	69,2	57,3	16,3
0280	12.400	48,7	45,4	15,8	57,2	48,7	16,0	62,0	50,9	16,1	65,4	52,2	16,1	68,9	53,4	16,2	72,6	54,7	16,3	76,5	55,8	16,4
	15.500	50,4	50,1	15,9	59,0	54,3	16,1	64,0	57,0	16,1	67,5	58,7	16,2	71,1	60,2	16,3	74,9	61,8	16,4	78,8	63,2	16,5
	18.600	51,9	53,6	16,0	60,6	58,9	16,1	65,6	62,5	16,2	69,1	64,5	16,3	72,7	66,5	16,4	76,5	68,3	16,5	80,4	70,1	16,5
0320	12.400	51,9	47,2	17,3	60,6	50,5	17,5	65,6	52,7	17,7	69,1	54,0	17,7	72,8	55,2	17,9	76,6	56,4	18,0	80,6	57,5	18,1
	15.500	53,8	52,1	17,4	62,7	56,3	17,6	67,8	58,9	17,7	71,4	60,5	17,8	75,1	62,0	17,9	79,0	63,5	18,0	83,0	64,9	18,1
	18.600	55,4	56,2	17,4	64,3	61,3	17,6	69,5	64,6	17,8	73,1	66,5	17,9	76,8	68,4	18,0	80,7	70,1	18,1	84,8	71,9	18,2
0360	12.800	59,0	53,5	19,1	68,1	55,9	19,6	73,3	57,4	19,9	77,0	58,3	20,1	80,8	59,1	20,3	84,7	59,9	20,6	88,7	60,3	20,8
	16.000	61,3	59,1	19,2	70,6	62,1	19,7	75,9	64,0	20,0	79,6	65,2	20,3	83,5	66,2	20,5	87,5	67,2	20,8	91,5	67,8	21,0
	19.200	63,0	64,0	19,3	72,4	67,7	19,8	77,8	70,1	20,1	81,6	71,5	20,4	85,5	72,8	20,6	89,6	74,1	20,9	93,6	74,9	21,1
0380	12.800	64,8	55,4	22,0	75,2	58,6	22,6	81,3	60,7	23,0	85,5	62,0	23,3	89,8	63,1	23,5	94,3	64,3	23,8	99,0	65,3	24,1
	16.000	67,6	60,8	22,1	78,2	64,8	22,8	84,4	67,5	23,2	88,6	69,0	23,4	93,0	70,5	23,7	97,6	71,8	24,0	102,3	73,2	24,3
	19.200	69,7	65,9	22,3	80,4	70,6	22,9	86,7	73,7	23,3	91,0	75,5	23,6	95,4	77,2	23,9	100,0	78,9	24,2	104,7	80,6	24,5

Pft: Total gross cooling capacity in kW  
 Pfs: Sensitive cooling capacity in kW  
 Pa: Compressor power input in kW

### Correction coefficients: variation of outdoor temperature and humidity

Outdoor temp.	20°C	25°C	30°C	35°C	40°C	45°C	48°C	Relative humidity	40%	50%	60%	70%	80%	90%	Correction
Coefficient K1	1,161	1,111	1,045	1,000	0,939	0,874	0,845	Coefficient K4	0,962	1,000	1,045	1,089	1,133	1,176	<b>PFT = Pft x K1 x K4</b>
Coefficient K2	1,085	1,058	1,030	1,000	0,968	0,934	0,910	Coefficient K5	1,108	1,000	0,929	0,760	0,684	0,532	<b>PFS = Pfs x K2 x K5</b>
Coefficient K3	0,711	0,797	0,893	1,000	1,119	1,249	1,332	Coefficient K6	0,992	1,000	1,010	1,020	1,031	1,040	<b>PA = Pa x K3 x K6</b>

## HEATING CAPACITY (kW)

### Indoor temperature 20°C

IPJ series	Flow (m³/h)	Outdoor air temperature																	
		-15°C WB		-10°C WB		-5°C WB		-3°C WB		0°C WB		3°C WB		6°C WB		10°C WB		15°C WB	
		Pc	Pa	Pc	Pa	Pc	Pa	Pc	Pa	Pc	Pa	Pc	Pa	Pc	Pa	Pc	Pa	Pc	Pa
0090	4.080	11,6	4,3	13,4	4,5	15,7	4,6	16,6	4,7	18,2	4,8	19,7	4,9	21,3	5,1	23,6	5,3	26,7	5,6
	5.100	12,0	4,2	13,7	4,3	15,8	4,4	16,9	4,5	18,4	4,5	19,9	4,6	21,6	4,7	23,9	4,9	27,2	5,1
	6.120	12,1	4,0	13,8	4,2	15,9	4,2	17,1	4,3	18,6	4,4	20,1	4,4	21,9	4,5	24,1	4,7	27,6	4,8
0120	5.200	14,5	5,4	16,9	5,6	19,4	5,8	21,2	6,0	23,0	6,1	24,8	6,3	26,9	6,5	29,5	6,7	33,2	7,1
	6.500	14,6	4,1	16,9	5,4	19,5	5,5	21,4	5,6	23,3	5,8	25,1	5,9	27,2	6,0	30,0	6,2	33,9	6,5
	7.800	14,7	5,1	17,0	5,2	19,6	5,3	21,4	5,4	23,4	5,5	25,3	5,6	27,5	5,7	30,2	5,9	34,3	6,1
0140	6.800	18,4	6,4	20,6	6,6	23,5	6,7	24,8	6,9	27,0	7,0	29,2	7,1	31,6	7,3	34,7	7,4	39,3	7,7
	8.500	18,5	6,3	20,8	6,3	23,6	6,5	25,0	6,5	27,3	6,6	29,5	6,7	32,0	6,9	35,2	7,0	40,0	7,2
	10.200	18,7	6,1	21,0	6,1	23,8	6,2	25,2	6,3	27,5	6,4	29,7	6,5	32,3	6,6	35,5	6,7	40,5	6,8
0160	7.000	19,8	7,0	22,7	7,2	26,3	7,5	27,7	7,6	30,1	7,8	32,4	8,1	35,1	8,4	38,4	8,8	43,4	9,4
	8.750	19,8	6,6	22,9	6,8	26,4	7,0	27,9	7,2	30,3	7,4	32,7	7,6	35,5	7,9	39,0	8,2	44,3	8,7
	10.500	20,0	6,4	23,1	6,6	26,6	6,8	28,1	6,9	30,6	7,1	33,0	7,3	35,8	7,5	39,5	7,8	44,9	8,2
0180	7.200	22,6	7,8	26,2	8,2	30,0	8,6	31,7	8,8	34,4	9,1	37,0	9,6	40,1	9,9	44,0	10,4	49,6	11,2
	9.000	22,7	7,4	26,3	7,7	30,3	8,1	32,0	8,2	34,8	8,5	37,5	8,9	40,6	9,2	44,7	9,6	50,6	10,3
	10.800	22,8	7,1	26,4	7,4	30,4	7,7	32,2	7,9	35,0	8,1	37,9	8,4	41,0	8,7	45,2	9,1	51,3	9,7
0190	7.200	24,3	8,7	28,0	8,9	32,1	9,3	33,8	9,6	36,7	9,9	39,6	10,3	42,7	10,7	46,9	11,3	52,6	12,1
	9.000	24,4	8,1	28,2	8,5	32,3	8,9	34,2	9,1	37,1	9,4	40,1	9,7	43,4	10,0	47,6	10,5	53,7	11,1
	10.800	24,5	7,9	28,3	8,2	32,5	8,5	34,4	8,7	37,4	9,0	40,4	9,2	43,9	9,5	48,2	9,9	54,6	10,5
0200	9.600	26,7	9,7	30,9	10,0	36,3	10,5	38,5	10,6	42,0	10,9	45,4	11,2	49,4	11,6	54,2	12,0	61,2	12,7
	12.000	26,7	9,3	31,1	9,6	36,5	9,9	38,8	10,0	42,4	10,3	45,9	10,5	50,0	10,8	55,1	11,1	62,4	11,7
	14.400	26,9	8,9	31,4	9,2	36,7	9,5	39,0	9,7	42,7	9,8	46,3	10,0	50,5	10,2	55,7	10,5	63,3	11,0
0220	10.000	30,1	11,0	35,1	11,4	40,5	11,9	42,8	12,1	46,5	12,5	50,2	12,8	54,3	13,2	59,5	13,7	66,9	14,5
	12.500	30,3	10,5	35,3	10,8	40,8	11,2	43,2	11,4	47,0	11,7	50,7	11,9	55,1	12,3	60,5	12,6	68,3	13,3
	15.000	30,3	10,1	35,4	10,4	41,0	10,8	43,4	10,9	47,3	11,1	51,1	11,4	55,6	11,6	61,2	11,9	69,3	12,4
0240	10.000	32,0	11,9	37,0	12,4	42,7	12,8	45,1	13,1	48,9	13,4	52,7	13,8	57,0	14,1	62,3	14,6	70,1	15,4
	12.500	31,9	11,4	37,3	11,7	43,1	12,1	45,5	12,3	49,5	12,5	53,3	12,8	57,9	13,1	63,4	13,5	71,6	14,1
	15.000	32,3	11,1	37,5	11,3	43,3	11,6	45,8	11,8	49,8	12,0	53,8	12,2	58,4	12,5	64,2	12,8	72,7	13,2
0280	12.400	35,1	13,5	41,7	13,9	48,4	14,3	51,1	14,5	55,6	14,8	60,0	15,1	65,1	15,4	71,3	15,8	80,7	16,4
	15.500	35,4	13,0	42,0	13,3	48,8	13,6	51,6	13,7	56,2	14,0	60,7	14,2	66,0	14,4	72,5	14,7	82,4	15,2
	18.600	35,7	12,4	42,3	12,7	49,0	13,1	51,9	13,2	56,6	13,4	61,2	13,6	66,6	13,8	73,3	14,0	83,5	14,4
0320	12.400	38,9	14,2	44,8	14,6	51,6	15,2	54,5	15,5	59,1	15,9	63,7	16,4	69,1	16,9	75,7	17,5	85,4	18,5
	15.500	39,2	13,6	45,1	14,0	52,1	14,4	55,0	14,6	59,8	15,0	64,6	15,3	70,1	15,7	77,0	16,3	87,3	17,0
	18.600	39,5	13,0	45,4	13,3	52,3	13,9	55,3	14,0	60,2	14,3	65,1	14,6	70,8	15,0	77,9	15,4	88,5	16,1
0360	12.800	43,8	15,7	50,7	16,4	58,3	17,1	61,5	17,6	66,7	18,2	71,8	18,9	77,6	19,7	85,1	20,7	95,9	22,3
	16.000	44,3	14,8	51,2	15,4	58,8	16,1	62,1	16,5	67,4	17,0	72,7	17,6	78,9	18,2	86,6	19,1	98,1	20,4
	19.200	44,8	13,9	51,6	14,6	59,1	15,5	62,5	15,7	67,9	16,2	73,4	16,7	79,7	17,3	87,7	18,0	99,7	19,2
0380	12.800	49,7	17,9	57,1	18,8	65,4	19,8	68,9	20,4	74,7	21,1	80,4	21,9	86,8	22,9	95,0	24,1	106,6	26,0
	16.000	49,9	17,1	57,5	17,8	66,0	18,7	69,6	19,2	75,6	19,8	81,5	20,5	88,3	21,3	96,8	22,3	109,2	23,8
	19.200	50,3	16,4	57,9	17,2	66,4	18,0	70,1	18,3	76,2	18,9	82,4	19,5	89,4	20,1	98,2	21,0	111,2	22,3

Pc: Total gross heating capacity in kW

Pa: Compressor power input in kW

### Correction coefficients: variation of indoor temperature

Indoor temperature	10°C	12°C	14°C	16°C	18°C	20°C	21°C	22°C	23°C	24°C	25°C	26°C	27°C	Correction
Coefficient K1	1,042	1,033	1,026	1,017	1,009	1,000	0,995	0,991	0,986	0,982	0,977	0,972	0,969	<b>PC = Pc x K1</b>
Coefficient K2	0,790	0,836	0,869	0,911	0,954	1,000	1,024	1,047	1,072	1,098	1,123	1,150	1,178	<b>PA = Pa x K2</b>

## OPTIONS FOR THE OUTDOOR UNIT

### Axial 2-speed outdoor fan

Vectios™ PJ		0090	0120	0140	0160	0180	0190	0200	0220	0240	0280	0320	0360	0380
Nominal air flow	(m <sup>3</sup> /h)	9.000	14.500	17.000	17.000	17.000	17.750	31.000	31.000	31.000	33.000	33.000	34.500	35.000
Available static pressure	(mm.w.c.)	4												
Number	(mm)	1	1				2							
Diameter	(mm)	630	800				800							
Output	(kW)	0,4 / 0,6	1,2 / 1,9				2 x (1,2 / 1,9)							
Maximum speed	(r.p.m.)	690 / 840	670 / 880				670 / 880							
Maximum absorbed current	(A)	1,2	3,9				2 x 3,9							

## OPTIONS FOR THE INDOOR UNIT

### Stop-drop in the indoor air coil

Air flow at which it is recommended to install a stop-drop in the indoor coil.

Vectios™ PJ	0090	0120	0140	0160	0180	0190	0200	0220	0240	0280	0320	0360	0380
Air flow (m <sup>3</sup> /h)	7.776	7.776	10.206	10.206	10.206	10.206	14.580	14.580	14.580	14.580	18.468	18.468	18.468

Note: for operating conditions with high dehumidification in the indoor coil (e.g. in installations close to the coast) it may be necessary to install a separator even if the flow is less than the previous one.

Note: with hot water coil it is not possible to assemble the stop-drop.

### Supply plug-fan EC with high (H) or low (L) available pressure

Vectios™ PJ		0090	0120	0140	0160	0180	0190	0200	0220	0240	0280	0320	0360	0380	
Nominal air flow	(m <sup>3</sup> /h)	5.100	6.500	8.500	8.750	9.000	9.000	12.000	12.500	12.500	15.500	15.500	16.000	16.000	
Nominal available static pressure	(mm.w.c.)	12	12	12	15	15	15	20	20	20	20	20	25	25	
Low pressure (L)	Number / Diameter	(mm)	1 / 500		--			--				--		2 / 500	
	Output	(kW)	1,3		--			5,6				--		2 x 2,6	
	Speed	(r.p.m.)	1.350		--			2.200				--		1.700	
	Maximum absorbed current	(A)	2,1		--			8,9				--		2 x 4,0	
High pressure (H)	Number / Diameter	(mm)	--		2 / 500			--				2 / 500			
	Output	(kW)	--		2 x 2,6			--				2 x 5,6			
	Speed	(r.p.m.)	--		1.700			--				2.200			
	Maximum absorbed current	(A)	--		2 x 4,2			--				2 x 8,4			

Note: the value of power input according to the selected flow can be found at our "Selection Software".

### Axial return fan (CA assembly)

Vectios™ PJ		0090	0120	0140	0160	0180	0190	0200	0220	0240	0280	0320	0360	0380	
Maximum air flow	(m <sup>3</sup> /h)	5.100	6.500	8.500	8.750	9.000	9.000	12.000	12.500	12.500	15.500	15.500	16.000	16.000	
Available static pressure	(mm.w.c.)	5													
Number / Diameter	(mm)	1 / 500		2 / 450			--				2 / 500		3 / 500		
Output	(kW)	0,7		2 x 0,5			--				2 x 0,7		3 x 0,7		
Speed	(r.p.m.)	1.390		1.360			--				1.390		1.390		
Maximum absorbed current	(A)	1,4		2 x 1,0			--				2 x 1,4		3 x 1,4		

**Centrifugal return fan (CQ / CT assemblies)**

Vectios™ PJ		0090	0120	0140	0160	0180	0190	0200	0220	0240	0280	0320	0360	0380	
Option 1: Low flow + nominal pressure	Available pressure (mm.w.c.)	20													
	Air flow (m³/h)	4.080	5.200	6.960	7.400	7.560	7.560	9.600	10.000	10.000	12.800	12.800	13.200	13.200	
	Motor output (kW)	0,75	1,10	1,50	2,20	2,20	2,20	2,20	2,20	2,20	2,20	2 x 1,50	2 x 1,50	2 x 1,50	2 x 1,50
	Power input (kW)	0,73	1,20	1,46	1,65	1,73	1,73	1,88	2,06	2,06	2,06	2 x 1,22	2 x 1,22	2 x 1,30	2 x 1,30
	Max. abs. current (A)	2,10	3,20	4,10	6,90	6,90	6,90	6,90	6,90	6,90	6,90	2 x 4,10	2 x 4,10	2 x 4,10	2 x 4,10
	Speed (r.p.m.)	888	976	806	830	839	839	683	696	696	696	779	779	788	788
	Code	OPK0671	OPK0673	OPK0677	OPK0684	OPK0684	OPK0684	OPK0682	OPK0682	OPK0682	OPK0682	2 x OPK0677	2 x OPK0677	2 x OPK0677	2 x OPK0677
Option 2: Low flow + high pressure	Available pressure (mm.w.c.)	50													
	Air flow (m³/h)	4.080	5.200	6.960	7.400	7.560	7.560	9.600	10.000	10.000	12.800	12.800	13.200	13.200	
	Motor output (kW)	1,50	2,20	3,00	3,00	3,00	3,00	3,00	4,00	4,00	4,00	2 x 2,20	2 x 2,20	2 x 2,20	2 x 2,20
	Power input (kW)	1,26	1,78	2,26	2,50	2,59	2,59	2,96	3,12	3,12	3,12	2 x 2,02	2 x 2,02	2 x 2,11	2 x 2,11
	Max. abs. current (A)	4,10	6,90	7,20	7,20	7,20	7,20	7,20	9,00	9,00	9,00	2 x 6,90	2 x 6,90	2 x 6,90	2 x 6,90
	Speed (r.p.m.)	1.326	1.341	1.133	1.139	1.142	1.142	954	958	958	958	1.130	1.130	1.131	1.131
	Code	OPK0672	OPK0674	OPK0680	OPK0680	OPK0680	OPK0680	OPK0681	OPK0683	OPK0683	OPK0683	2 x OPK0676	2 x OPK0676	2 x OPK0676	2 x OPK0676
Option 3: Nominal flow + nominal pressure	Available pressure (mm.w.c.)	20													
	Air flow (m³/h)	5.100	6.500	8.700	9.250	9.450	9.450	12.000	12.500	12.500	16.000	16.000	16.500	16.500	
	Motor output (kW)	1,10	1,50	1,50	2,20	2,20	2,20	2,20	2,20	2,20	2,20	2 x 1,50	2 x 1,50	2 x 1,50	2 x 1,50
	Power input (kW)	1,15	1,26	1,55	1,73	1,81	1,81	2,00	2,18	2,18	2,18	2 x 1,30	2 x 1,30	2 x 1,38	2 x 1,38
	Max. abs. current (A)	3,20	4,10	4,10	6,90	6,90	6,90	6,90	6,90	6,90	6,90	2 x 4,10	2 x 4,10	2 x 4,10	2 x 4,10
	Speed (r.p.m.)	967	783	656	672	679	679	545	553	553	553	637	637	644	644
	Code	OPK0673	OPK0677	OPK0678	OPK0682	OPK0682	OPK0682	OPK0685	OPK0685	OPK0685	OPK0685	2 x OPK0678	2 x OPK0678	2 x OPK0678	2 x OPK0678
Option 4: Nominal flow + high pressure	Available pressure (mm.w.c.)	50													
	Air flow (m³/h)	5.100	6.500	8.700	9.250	9.450	9.450	12.000	12.500	12.500	16.000	16.000	16.500	16.500	
	Motor output (kW)	2,20	2,20	3,00	3,00	3,00	3,00	4,00	4,00	4,00	4,00	2 x 3,00	2 x 3,00	2 x 3,00	2 x 3,00
	Power input (kW)	1,72	2,07	2,56	2,79	2,88	2,88	3,46	3,67	3,67	3,67	2 x 2,30	2 x 2,30	2 x 2,39	2 x 2,39
	Max. abs. current (A)	6,90	6,90	7,20	7,20	7,20	7,20	9,00	9,00	9,00	9,00	2 x 7,20	2 x 7,20	2 x 7,20	2 x 7,20
	Speed (r.p.m.)	1.338	1.130	949	951	953	953	797	799	799	799	949	949	949	949
	Code	OPK0674	OPK0676	OPK0681	OPK0681	OPK0681	OPK0681	OPK0686	OPK0686	OPK0686	OPK0686	2 x OPK0681	2 x OPK0681	2 x OPK0681	2 x OPK0681
Option 5: High flow + nominal pressure	Available pressure (mm.w.c.)	20													
	Air flow (m³/h)	6.120	7.800	10.440	11.100	11.340	11.340	14.400	15.000	15.000	19.200	19.200	19.800	19.800	
	Motor output (kW)	1,10	1,50	2,20	2,20	2,20	2,20	3,00	4,00	4,00	4,00	2 x 2,20	2 x 2,20	2 x 2,20	2 x 2,20
	Power input (kW)	1,13	1,24	2,28	1,72	1,79	1,79	2,90	3,14	3,14	3,14	2 x 1,88	2 x 1,88	2 x 2,01	2 x 2,01
	Max. abs. current (A)	3,20	4,10	6,90	6,90	6,90	6,90	7,20	9,00	9,00	9,00	2 x 6,90	2 x 6,90	2 x 6,90	2 x 6,90
	Speed (r.p.m.)	766	633	711	533	536	536	585	597	597	597	683	683	693	693
	Code	OPK0675	OPK0678	OPK0682	OPK0685	OPK0685	OPK0685	OPK0687	OPK0689	OPK0689	OPK0689	2 x OPK0682	2 x OPK0682	2 x OPK0682	2 x OPK0682
Option 6: High flow + high pressure	Available pressure (mm.w.c.)	50													
	Air flow (m³/h)	6.120	7.800	10.440	11.100	11.340	11.340	14.400	15.000	15.000	19.200	19.200	19.800	19.800	
	Motor output (kW)	2,20	2,20	4,00	4,00	4,00	4,00	5,50	5,50	5,50	5,50	2 x 3,00	2 x 3,00	2 x 4,00	2 x 4,00
	Power input (kW)	1,90	2,26	3,35	3,12	3,21	3,21	4,51	4,83	4,83	4,83	2 x 2,96	2 x 2,96	2 x 3,07	2 x 3,07
	Max. abs. current (A)	6,90	6,90	9,00	9,00	9,00	9,00	11,60	11,60	11,60	11,60	2 x 7,20	2 x 7,20	2 x 9,00	2 x 9,00
	Speed (r.p.m.)	1.131	950	964	796	796	796	809	814	814	814	954	954	957	957
	Code	OPK0676	OPK0679	OPK0683	OPK0686	OPK0683	OPK0683	OPK0688	OPK0688	OPK0688	OPK0688	2 x OPK0681	2 x OPK0681	2 x OPK0683	2 x OPK0683

### Return plug-fan EC (CP / CR / CQ / CT / TP assemblies)

Vectios™ PJ		0090	0120	0140	0160	0180	0190	0200	0220	0240	0280	0320	0360	0380
Nominal air flow	(m³/h)	5.100	6.500	8.500	8.750	9.000	9.000	12.000	12.500	12.500	15.500	15.500	16.000	16.000
Nominal available static pressure	(mm.w.c.)	12	12	12	15	15	15	20	20	20	20	20	25	25
Number / Diameter	(mm)	1 / 500						2 / 500						
Output	(kW)	2,6						2 x 2,6						
Speed	(r.p.m.)	1.700						1.700						
Maximum absorbed current	(A)	4,0						2 x 4,0						

Note: the value of power input according to the selected flow can be found at our "Selection Software".

### Return plug-fan EC (CW / TW assemblies)

Vectios™ PJ		0090	0120	0140	0160	0180	0190	0200	0220	0240	0280	0320	0360	0380
Nominal air flow	(m³/h)	5.100	6.500	8.500	8.750	9.000	9.000	12.000	12.500	12.500	15.500	15.500	16.000	16.000
Nominal available static pressure	(mm.w.c.)	12	12	12	15	15	15	20	20	20	20	20	25	25
Nominal pressure (N)	Number / Diameter	(mm)	1 / 500						2 / 500					
	Output	(kW)	2,6						2 x 2,6					
	Speed	(r.p.m.)	1.700						1.700					
	Maximum absorbed current	(A)	4,0						2 x 4,0					
High pressure (H)	Number / Diameter	(mm)	--	1 / 500				--	2 / 500					
	Output	(kW)	--	2,8				--	2 x 2,8					
	Speed	(r.p.m.)	--	1700				--	1.700					
	Maximum absorbed current	(A)	--	4,3				--	2 x 4,3					

Note: the value of power input according to the selected flow can be found at our "Selection Software".

### Rotary heat exchange (CW / TW assemblies)

This rotary recovery unit is used to transfer the sensible and latent heat from the air-conditioned room's return air to the fresh air used for ventilation, before it's discharged outdoors.

The return air circulates in half of the heat recovery unit and the ventilation air circulates in the other half, in the opposite direction. As the rotor rotates, very fine channels of air which form the matrix come into contact with the fresh air and the return air in turn, thereby transferring heat and humidity from one to the other.

The efficiency of the recovery depends on the following factors:

- **Wheel diameters:**
  - 800 mm: models 0090 to 0190
  - 1200 mm: models 0200 to 0240
  - 1500 mm: models 0280 to 0380
- **Matrix materials:**
  - Aluminum: sensible heat recovery.
  - Epoxy coated aluminium: sensible heat recovery in aggressive environments.
  - Hybrid wheel: enthalpic recovery.
  - Silicagel coated aluminium: enthalpic recovery with high efficiency in the recovery of latent heat.
- **Channel cross section:**

The wheel is formed of two panels of aluminium, one smooth and one fluted. The fluted panel can be provided in two different configurations:

  - 2.0 mm cross section: the commonly-used cross section due to its high efficiency and moderate pressure drops.
  - 2.5 mm cross section: low pressure drop. Designed for high frontal speeds with low pressure drops.

The rotary heat exchanger is fitted into a module placed on one side of the unit.

This module features filters on the fresh air intake and the exhaust air outlet: gravimetric filters G4 (default option), G4 with low pressure drop or G4 + M6 (optional).

This assembly can be supplied, in option, with a speed drive for the wheel which avoids the risk of ice forming on the wheel during the defrost operation. The speed drive is compulsory with output temperatures on both sides of the wheel lower than 1°C or an average temperature on the wheel lower than 3°C.



**Important:** the calculations for the selection of a rotary heat exchanger according to the parameters described above should be done using our "Selection Software".

### Cooling recovery circuit (CR / CT assemblies)

Thermodynamic circuit dedicated to the recovery of the extracted air energy, with independent and proportional control, adapted to the air renewal requirements in order to raise the COP, EER and seasonal efficiency of the unit set.

The circuit is composed of:

- Return EC plug-fan.
- Air circuit comprised of coils with copper pipes and aluminium fins.
- Electronic expansion valve.
- Hermetic scroll-type compressor with sound insulation, assembled over antivibration mounts.
- Crankcase heater.
- Four-way cycle reversing valve.
- Anti-acid dehydrator filter.
- High and low pressure transducers.
- Condensates drain pan.

Vectios™ PJ		0090 to 0120	0140 to 0190	0200 to 0240	0280 to 0380
Compressor type		Scroll			
No. of compressors / circuits		1 / 1			
Max. absorbed current	(A)	5,4	7,2	10,1	12,1
Oil type		Copeland 3MAF 32cST, Danfoss POE 160SZ, ICI Emkarate RL 32CF, Mobil EAL Artic 22CC			
Volume of oil	(l)	0,7	1,2	1,7	1,8
Charge of R-410A	(kg)	1,7	2,5	3,0	3,4
Environment impact	(tCO2eq)	3,5	5,2	6,3	7,1

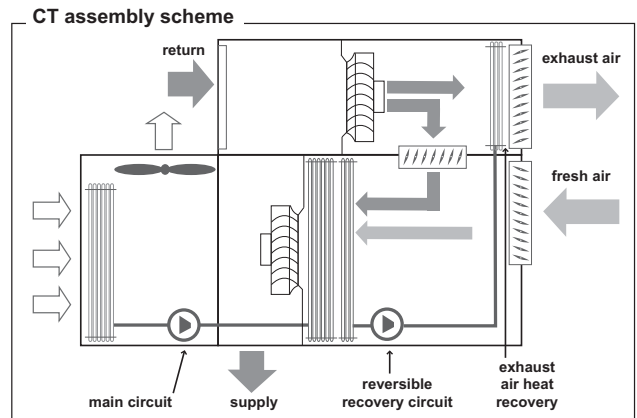
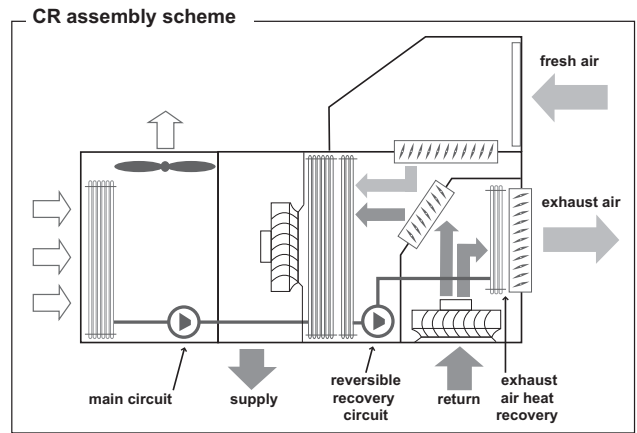

### Total cooling capacity with recovery circuit

Vectios™ PJ			0090	0120	0140	0160	0180	0190	0200	0220	0240	0280	0320	0360	0380	
Nominal air flow			(m³/h)	5.100	6.500	8.500	8.750	9.000	9.000	12.000	12.500	12.500	15.500	15.500	16.000	16.000
Outdoor temperature 35°C / 40% HR Indoor temperature 27°C / 50% HR	20% fresh air	Pft (kW)	29,6	36,2	45,7	49,5	54,3	56,7	70,4	75,4	77,9	90,7	94,7	103,5	112,8	
		Pfs (kW)	23,7	29,6	38,1	40,2	42,5	43,4	55,9	59,0	59,9	72,1	73,6	78,2	81,7	
		Pa (kW)	8,5	9,6	11,5	12,8	14,0	14,7	17,8	19,5	20,5	21,7	23,3	25,8	29,0	
	40% fresh air	Pft (kW)	31,3	37,9	48,3	52,0	56,9	59,4	73,7	78,8	81,4	95,2	99,3	108,1	117,7	
		Pfs (kW)	25,0	31,1	39,7	41,8	44,3	45,3	58,8	62,0	62,9	76,0	77,4	82,0	85,6	
		Pa (kW)	8,1	9,3	10,9	12,3	13,5	14,2	17,1	18,9	19,9	20,9	22,6	25,1	28,3	
	80% fresh air	Pft (kW)	33,6	40,3	51,9	55,7	60,8	63,3	78,7	84,0	86,8	102,3	106,4	115,2	125,4	
		Pfs (kW)	27,4	33,6	42,4	44,4	47,0	47,9	62,4	65,8	66,9	82,3	84,1	88,0	92,7	
		Pa (kW)	8,0	9,1	10,6	12,1	13,4	14,0	16,8	18,5	19,6	20,6	22,2	25,0	28,2	

Pft: Total gross cooling capacity (sum of the power of the main circuit and the recovery circuit)

### Total heating capacity with recovery circuit

Vectios™ PJ			0090	0120	0140	0160	0180	0190	0200	0220	0240	0280	0320	0360	0380	
Nominal air flow			(m³/h)	5.100	6.500	8.500	8.750	9.000	9.000	12.000	12.500	12.500	15.500	15.500	16.000	16.000
Outdoor temperature 6°C BH Indoor temperature 20°C	20% fresh air	Pct (kW)	29,6	35,7	44,1	47,7	52,8	55,5	68,0	73,2	75,9	87,5	91,6	100,6	110,0	
		Pa (kW)	6,6	7,8	9,2	10,2	11,5	12,3	14,6	16,1	16,9	18,6	19,9	22,5	25,6	
	40% fresh air	Pct (kW)	30,9	37,0	45,9	49,6	54,8	64,2	70,6	75,9	78,7	90,7	94,8	103,9	113,4	
		Pa (kW)	6,4	7,5	8,8	9,8	11,0	11,8	14,0	15,4	16,3	17,9	19,1	21,5	24,5	
	80% fresh air	Pct (kW)	32,6	38,8	47,5	52,0	57,4	60,2	74,4	79,7	82,6	95,1	99,3	108,5	118,3	
		Pa (kW)	5,9	6,8	8,1	8,9	10,0	10,8	12,8	14,0	14,8	16,3	17,4	19,6	22,3	

Pct: Total gross heating capacity (sum of the power of the main circuit and the recovery circuit)



### Auxiliary electrical heaters

Auxiliary electrical heaters, with two power stages and on/off control, for assembly and connection inside the unit.

■ Up to 3 values of total power available for each model:

Vectios™ PJ	E0L (Low)	E0N (Nominal)	E0H (High)
0090 to 0120	12 kW	18 kW	unavailable
0140 to 0190	12 kW	18 kW	27 kW
0200 to 0380	18 kW	27 kW	36 kW

■ Characteristics:

Total power (kW)	12	18	27	36
Stages power (kW)	6 + 6	9 + 9	9 + 18	18 + 18
Current (400 V / III ph) (A)	17,3	26,0	39,0	52,0
Power supply	400 V / III ph			

### Auxiliary hot water coil

Auxiliary hot water coil, with three-way valve and proportional control, for assembly and connection inside the unit.

This option always incorporates an anti-freeze thermostat as safety system.

Vectios™ PJ		0090	0120	0140	0160	0180	0190	0200	0220	0240	0280	0320	0360	0380	
Air pressure drop	(mm.w.c.)	2,4	3,5	3,5	3,6	4,3	4,3	3,4	3,6	3,6	3,5	3,7	3,7	3,7	
Water 80/60°C and inlet air 20°C	Heating capacity	(kW)	27,6	32,0	47,6	48,4	49,2	49,2	95,8	98,3	98,3	129,0	129,0	131,5	131,5
	Water flow	(m³/h)	1,4	1,6	2,1	2,1	2,1	2,1	2,7	2,8	2,8	3,6	3,6	3,7	3,7
	Water pressure drop	(m.w.c)	0,2	0,3	0,5	0,5	0,5	0,5	0,5	0,5	0,5	0,9	0,9	1,0	0,9
Water 90/70°C and inlet air 20°C	Heating capacity	(kW)	34,2	39,8	58,7	59,8	90,8	90,8	118,5	121,5	121,5	158,7	158,7	161,9	161,9
	Water flow	(m³/h)	1,7	2,0	2,6	2,6	2,6	2,6	3,4	3,4	3,4	4,5	4,5	4,6	4,6
	Water pressure drop	(m.w.c)	0,3	0,4	0,7	0,7	0,8	0,8	0,7	0,7	0,7	1,3	1,4	1,4	1,4

Note: With stop-drop in the indoor air coil it is not possible to assemble the hot water coil.

### Position of the hydraulic connections of the hot water coil

#### Cross flow assemblies

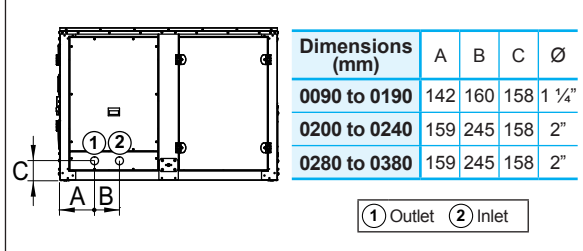

#### Tunnel flow assemblies

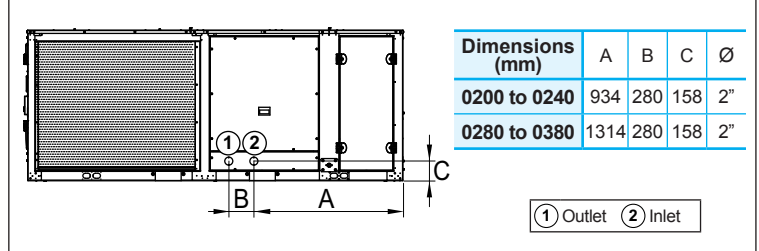

Note: The Input / Output connections of the coil are located inside the unit. The connection can be established via the unit base using flexible tubing or via the side panel. In the above diagrams, the position of the sheet metal precuts is shown on the side panel.

### “Great Cold” option (B0C)

Note: on units with the “Great Cold” option, air supply only may be lateral (factory-configured).

- This anti-freeze safety incorporates:
  - Circulation pump.
  - Water temperature sensors located in the inlet and the outlet of the coil.

Important: this option is mandatory for an outdoor temperature lower than -20°C WB. Consult for percentages of glycol water above 20%.

■ Characteristics of the water circuit:

Vectios™ PJ		0090 to 0200	0220 to 0380
Circulation pump	Motor output (W)	90	140
	Max. absorbed current (A)	0,75	1,15

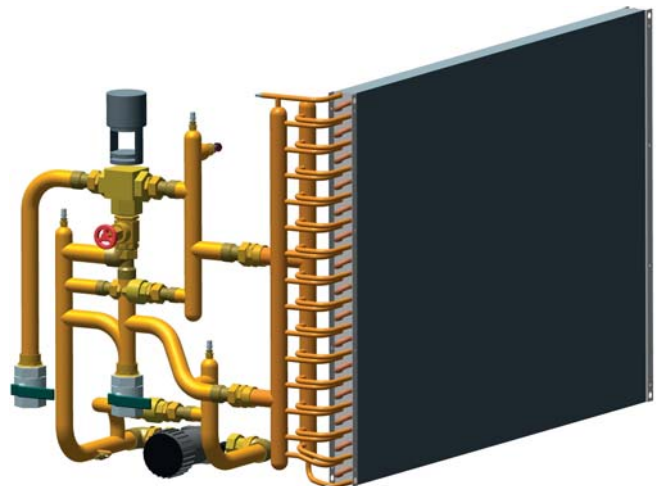

### Gas boiler + Auxiliary hot water coil

Natural or propane gas boiler with modulating actuator, in accordance with the Gas Directive 2009/142/EC, mounted on the side of the unit.

■ Up to 3 values of total power available for each model:

Vectios™ PJ	G1L (Low)	G1N (Nominal)	G1H (High)
0090 to 0190	unavailable	Condexa PRO 40 (coming soon)	Condexa PRO 70
0200 to 0380	Condexa PRO 50 (coming soon)	Condexa PRO 70	Condexa PRO 100

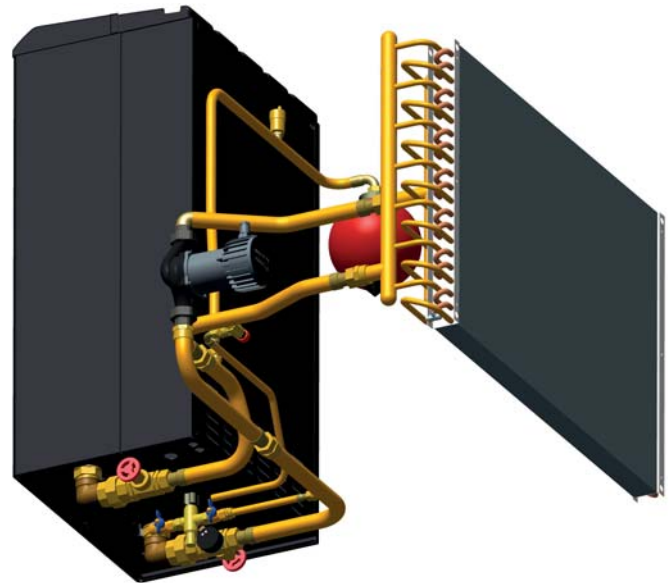

■ Characteristics of the water circuit:

Vectios™ PJ		0090 to 0200	0220 to 0380
Expansion vessel	Volume (l)	5	5
	Filling pressure (kg/cm <sup>2</sup> )	1,5	1,5
Circulation pump	Motor output (W)	90	140
	Max. absorbed current (A)	0,75	1,15

■ The key features of the boiler are:

- Burner with premixing and modulation technology that allows outputs close to 109% (Hi performance).
- Heat exchanger made of stainless steel with a low carbon content.
- Proportional air / gas valve. Low NOx emissions (class 5, according to standard EN 297).
- Condensate drain with siphon.
- Forced draught.
- Electronic ignition.
- Safety devices: safety thermostat, low water pressure safety switch, flowmeter, Delta-T control, smoke temperature sensor.
- NTC sensor for boiler water temperature regulation.
- Working temperature of water from -7°C to 100°C. Consult for percentages of glycol water above 20%.
- Electronic controller with microprocessor and Multifunction LCD display for boiler's control, configuration and diagnostics. Possibility of ModBus communication.
- The electronic control of the unit will only manage the boiler connection as heating support depending on the ambient conditions.

■ The boiler is connected to the hydraulic circuit of the auxiliary hot water coil. The water circuit, installed inside the unit, is composed of:

- Water coil.
- Circulation pump.
- Expansion vessel.
- Gate valves.
- Safety valve with a tare value of 4 bar.
- Automatic air bleeder valve.

■ Type of gas used depending on the destination country:

Country	Category	Gas	Pressure (mbar)	Gas	Pressure (mbar)
Italy, Ireland, Great Britain, Portugal, Slovenia, Slovakia, Greece	I12H3+	G20	20	G30/G31	28-30/37
Spain	I12H3+	G20	18	G30/G31	28-30/37
Romania, Bulgaria, Turkey, Denmark, Estonia, Sweden, Norway, Latvia, Lithuania, Finland, Russia	I12H3B/P	G20	20	G30	30
Hungary	I12H3B/P	G20	25	G30	30
Poland	I12H3B/P	G20	25	G30	37
Croatia	I12H3B/P	G20	20	G30/G31	30
Holland	I12H3B/P	G25	25	G30	30
Czech Republic, Austria, Switzerland	I12H3B/P	G20	20	G30	50
Luxembourg	I12H3B/P	G20	20	G30	50
	I12E3P	G20	20	G31	37
Belgium	I2E(S)	G20/G25	20/25	--	--
	I3+	--	--	G30/G31	28-30/37
France	I12E+3+,	G20/G25	20/25	G30/G31	28-30/37
Malta, Cyprus, Iceland	I3B/P	--	--	G30	30
Germany	I12ELL3B/P	G20/G25	25	G30	50

■ Technical characteristics of the boiler:

Model		Condexa PRO 40 (coming soon)	Condexa PRO 50 (coming soon)	Condexa PRO 70	Condexa PRO 100
Type of equipment		B23 - B53 - B53P			
EC certification		PIN. 0085CP0214			
NOx Class (according to standard EN 297)		Val 5			
Boiler performance	Total thermal power (Hs)			76/15	108/21,6
	Total thermal power (Hi)			68/14	97/19,4
	Nominal power supplied to the water 100% (80°C - 60°C)			66,7	95,2
	Nominal power supplied to the water 100% (50°C - 30°C)			73,5	105
	Nominal power supplied to the water 100% (60°C - 40°C)			71	101
	Condensate hourly production 100% (50°C - 30°C) with gas G20			8,5	12,3
	Performance with nominal power (80°C - 60°C)			98,1	98,1
	Performance with nominal power (50°C - 30°C)			108,1	108,2
	Performance with nominal power Tm = 50°C (60°C - 40°C)			104,4	104,1
	Performance with reduced load 30% (80°C - 60°C)			98,5	98,3
	Performance with reduced load 30% (50°C - 30°C)			109	109
	Performance with reduced load 30% Tm = 50°C (60°C - 40°C)			105,3	105
	Losses in enclosure (Tm = 70°C)			0,1	
Energy efficiency marking (Directive 92/42 EC)		★★★★			
Energy efficiency	Seasonal energy efficiency class in heating			A	A
	Seasonal energy efficiency in heating			92,7	92,7
Gas supply	Gas category	II2H3+			
	Natural Gas consumption (G20) (nominal / minimum)	m³/h		7,2/1,4	10,3/2,1
Electrical data	Power supply	230 Vac - 50 Hz			
	Power input at 100%	W		77	203
	Power input at 30%	W		30	31
	Power input in stand-by	W		13	6
	Ingress protection rating	IP X5D			
	Operating temperatures	de -15°C to +70°C			
Connections	Ø Gas supply			G1"	G1"
	Ø Flue outlet	mm		DN80	DN110
	Ø Condensate drain	mm		25	25
Heating circuit	Control of heating temperature (min. / max.)	°C 20 / 80			
	Working pressure (max. / min.)	bar 6 / 0,7			

### Heat recovery coil

The function of the heat recovery coil is to pre-heat the air that will pass through the main indoor coil. For this, it uses the temperature of an outdoor water installation. Unit's control doesn't manage this function.

This option is compatible with C0, CS, CQ, CT, T0 and TS assemblies.

Vectios™ PJ		0090	0120	0140	0160	0180	0190	0200	0220	0240	0280	0320	0360	0380	
Air pressure drop	(mm.w.c.)	2,6	3,9	5,0	5,5	5,7	5,7	4,3	4,6	4,6	4,5	4,5	4,7	4,7	
Water 35/30°C (30% MEG) and inlet air 20°C	Heating capacity	(kW)	11,2	13,0	17,0	17,5	17,8	17,8	23,7	24,6	24,6	32,8	32,8	33,4	33,4
	Water flow	(m³/h)	2,1	2,4	3,2	3,3	3,3	3,3	4,4	4,6	4,6	6,1	6,1	6,2	6,2
	Water pressure drop	(m.w.c.)	1,2	1,6	2,9	3,0	3,1	3,1	1,9	2,0	2,0	4,0	4,0	4,1	4,1

### Position of the hydraulic connections of the heat recovery coil

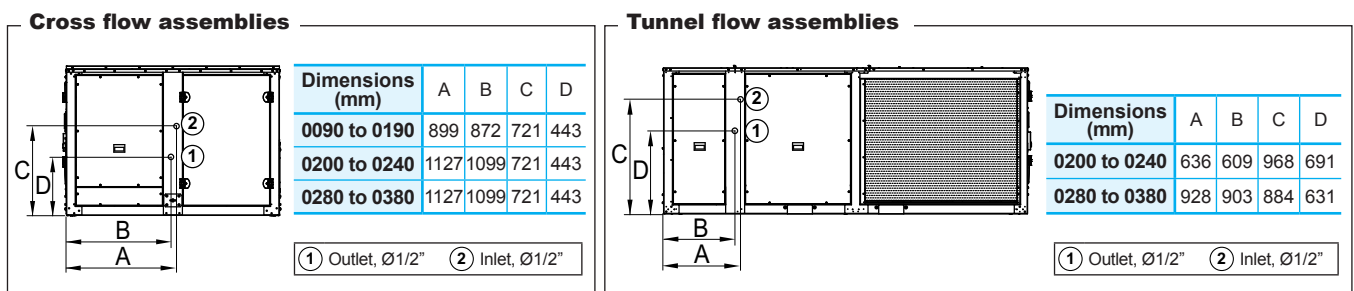

## Gas burner

Natural or propane gas burner with modulating actuator, in accordance with the Gas Directive 2009/142/EC, installed inside a pre-assembly roofcurb.

- Up to 3 values of total power available for each model:

Vectios™ PJ	G0L (Low)	G0N (Nominal)	G0H (High)
0090 to 0190	PCH020	PCH034	PCH045
0200 to 0240	unavailable	PCH065	PCH080
0280 to 0380	unavailable	PCH080	PCH105

- The key features of the boiler are:
  - Condensation boiler with premixing and modulation technology that allows outputs close to 109% (Hi performance).
  - The premixed burner, in combination with the air/gas valve, ensures a "clean" combustion. Low NOx emissions (class 5, according to standard EN 297).
  - The combustion chamber and the burner are entirely made of stainless steel.
  - Electronic controller with microprocessor and multifunction LCD display, located inside the burner, for burner's control, configuration and diagnostics.
  - The electronic control of the unit will only manage the burner connection as heating support depending on the ambient conditions.



Note: It's recommended to use the clogged filter pressostat (optional) in units with gas burner.

Model		PCH020	PCH034	PCH045	PCH065	PCH080	PCH105							
Type of equipment		B23P - B53P - C13 - C43 - C53 - C63 - C83												
EC certification		PIN.		0694CP1457										
NOx Class		Val		5										
Heater performance	Range	Min.	Max	Min.	Max	Min.	Max	Min.	Max	Min.	Max	Min.	Max	
	Thermal output (Hi)	kW	4,75	19,00	7,60	34,85	8,50	44,00	12,40	65,00	16,40	82,00	18,00	100,00
	Useful thermal output	kW	4,97	18,18	8,13	33,56	9,00	42,40	13,40	62,93	17,77	80,03	19,63	97,15
	Hi performance (L.C.V.)	%	104,63	95,68	106,97	96,30	105,88	96,37	108,06	96,82	108,35	97,60	109,06	97,15
	Hs performance (H.C.V.)	%	94,26	86,20	96,37	86,76	95,39	87,36	97,36	87,22	97,62	87,93	98,25	87,52
	Flue losses with burner off (Hi)	%	0,4	4,3	0,6	3,7	0,5	3,7	0,2	3,2	0,3	2,4	0,2	2,8
	Flue losses with burner off (Hi)	%	<0,1											
	Losses in enclosure ①		0%											
	Max. condensation ②	l/h	0,4	0,9	1,1	2,1	3,3	2,7						
Exhaust gases - Polluting emissions	Carbon monoxide - CO - (0% of O2) ③	ppm	< 5											
	Nitrogen oxides - NOx - (0% of O2) ④		40 mg/kWh - 22,28 ppm	41 mg/kWh - 23,24 ppm	35 mg/kWh - 19,84 ppm	40 mg/kWh - 22,68 ppm	34 mg/kWh - 19,27 ppm	45 mg/kWh - 25,51 ppm						
	Available pressure at flue	Pa	80	90	100	120								
Electrical data	Power supply	230 Vac - 50 Hz monofásico												
	Power input	12	45	11	74	24	82	15	97	40	123	20	130	
	Power input in stand-by	<5												
	Ingress protection rating	IP X5D												
	Operating Temperatures	from -15°C to +40°C												
Connections	Ø gas connection	GAS	UNI/ISO 7/1- 3/4"											
	Ø intake/exhaust pipes	mm	80/80											

① Enclosure losses match those of the machine housing the PCH.  
 ② Max. condensation produced acquired from testing 30%Qn.  
 ③ Value referenced to cat. H (G20)  
 ④ Weighted value to EN1020 ref. to class H (G20), referred to Hi (L.C.V.).

■ Gas setting:

Gas type	Gas settings	PCH020		PCH034		PCH045		PCH065		PCH080		PCH105		
		min.	max.	min.	max.	min.	max.	min.	max.	min.	max.	min.	max.	
G20	Air supply pressure	mbar 20 [min 17-max 25]												
	Ø pilot nozzle	mm 0,7												
	Gas consumption (15°C-1013mbar)	m3/h	0,51	2,01	0,80	3,69	0,90	4,66	1,31	6,88	1,74	8,68	1,90	10,58
	Carbon dioxide - CO <sub>2</sub> content	%	8,8	9,1	8,7	9,1	8,7	9,1	8,7	9,1	8,7	9,1	8,5	9,1
	Fumes temperature	°C	39	113	31	94	30	94	31	86	26,5	70	28	80
	Fume mass flow rate (max.)	kg/h	31		57		72		107		135		165	
	Gas butterfly valve	mm	5,8		7,4		7,5		11,0		12,2		15,8	
G25	Air supply pressure	mbar 25 [min 17-max 30] (20 for Germany)												
	Ø pilot nozzle	mm 0,7 (0,75 for Germany)												
	Gas consumption (15°C-1013mbar)	m3/h	0,59	2,34	0,93	4,29	1,05	5,41	1,53	8,00	2,02	10,1	2,21	12,30
	Carbon dioxide - CO <sub>2</sub> content	%	8,8	9,0	8,6	9,0	8,8	8,9	8,8	9,2	8,6	8,9	8,8	9,0
	Fumes temperature	°C	39	113	31	94	30	94	31	86	26,5	70	28	80
	Fume mass flow rate (max.)	kg/h	--											
G30	Gas butterfly valve	mm Not necessary												
	Air supply pressure	mbar 30 [min 25-max 35] - 50 [min 42,5-max 57,5]												
	Ø pilot nozzle	mm 0,51												
	Gas consumption (15°C-1013mbar)	m3/h	0,40	1,58	0,63	2,90	0,71	3,65	1,03	5,39	1,36	6,80	1,49	8,30
	Carbon dioxide - CO <sub>2</sub> content	%	10,8	11,4	10,8	11,5	10,8	10,9	10,7	11,3	11,2	11,6	10,9	11,2
	Fumes temperature	°C	39	113	31	94	30	94	31	86	26,5	70	28	80
G31	Fume mass flow rate (max.)	kg/h --												
	Gas butterfly valve	mm 3,7		5,0		5,2		6,5		7,0		9,3		
	Air supply pressure	mbar 30 [min 25-max 35] - 37 [min 25-max 45] - 50 [min 42,5-max 57,5]												
	Ø pilot nozzle	mm 0,51												
	Gas consumption (15°C-1013mbar)	m3/h	0,39	1,55	0,62	2,85	0,70	3,60	1,01	5,31	1,34	6,70	1,47	8,18
	Carbon dioxide - CO <sub>2</sub> content	%	9,3	9,8	9,2	9,7	9,3	9,4	9,4	9,6	9,3	9,6	9,1	9,6
G31	Fumes temperature	°C	39	113	31	94	30	94	31	86	26,5	70	28	80
	Fume mass flow rate (max.)	kg/h	24		45		58		84		107		130	
	Gas butterfly valve	mm 3,7		5,0		5,2		6,5		7,0		9,3		

■ Type of gas used depending on the destination country:

Country	Category	Gas	Pressure (mbar)	Gas	Pressure (mbar)
Austria, Switzerland	I12H3B/P	G20	20	G30/G31	50
Belgium < 70kW	I2E(S)B,I3P	G20/G25	20/25	G31	37
Belgium > 70kW	I2E(R)B,I3P	G20/G25	20/25	G31	37
Germany	I12ELL3B/P	G20	20	G30/G31	50
Denmark, Finland, Greece, Sweden, Norway, Italy, Czech Republic, Estonia, Lithuania, Slovenia, Albania, Macedonia, Bulgaria, Romania, Croatia, Turkey, Azerbaijan	I12H3B/P	G20	20	G30/G31	30
Spain, United Kingdom, Ireland, Portugal, Slovakia	I12H3P	G20	20	G31	37
France	I12Esi3P	G20/G25	20/25	G31	37
Luxembourg	I12E3P	G20/G25	20	G31	37/50
Netherlands	I12L3B/P	G25	25	G30/G31	50
Hungary	I12HS3B/P	G20/G25.1	25	G30/G31	30
Cyprus, Malta	I3B/P	--	--	G30/G31	30
Latvia	I2H	G20	20		
Iceland	I3P	--	--	G31	37
Poland	I12E3B/P	G20/G2.350	20/13	G30/G31	37
Russia	I12H3B/P	G20	20	G30/G31	30

**PRESSURE DROPS DUE TO THE INDOOR UNIT OPTIONS**

Vectios™ PJ	Flow (m³/h)	Pressure drops (mm.w.c)																			
		Filters ①										Stop-drop		H.W.C	E.H.	Gas burner					
		G4 l.p.d	G4 + M6	G4 + F7	G4 + F9	G4 l.p.d + F7	G4 l.p.d + F9	M6 + F7	M6 + F9	F7 + F9	F9 + F9	Ind. coil	Air intake ②			PCH-020	PCH-034	PCH-045	PCH-065	PCH-080	PCH-105
0090	4.080	-1,8	3,2	4,7	11,0	2,9	9,2	4,0	10,3	11,8	18,1	1,9	0,7	1,7	2,0	2,6	2,8	2,1	--	--	--
	5.100	-1,7	4,4	6,2	14,1	4,5	12,3	5,1	13,0	14,8	22,6	2,6	1,0	2,4	3,1	4,0	4,4	3,3	--	--	--
	6.120	-2,1	5,8	7,9	17,4	5,8	15,3	6,2	15,7	17,7	27,2	3,4	1,4	3,2	4,4	5,8	6,3	4,8	--	--	--
0120	5.200	-1,8	4,6	6,4	14,4	4,6	12,6	5,2	13,3	15,0	23,1	2,6	1,1	2,5	3,2	4,0	3,9	3,2	--	--	--
	6.500	-2,3	6,4	8,6	18,6	6,3	16,4	6,6	16,7	18,8	28,9	3,7	1,5	3,5	5,0	6,3	6,1	5,0	--	--	--
	7.800	-3,3	8,6	11,0	23,2	7,7	19,8	8,0	20,1	22,6	34,7	5,1	2,0	4,7	7,2	9,0	8,8	7,2	--	--	--
0140	6.800	-1,8	4,5	6,3	14,3	4,6	12,6	5,2	13,2	15,0	23,0	2,6	1,7	2,5	2,6	6,6	6,8	5,6	--	--	--
	8.500	-2,2	6,4	8,5	18,6	6,3	16,3	6,6	16,6	18,8	28,8	3,7	2,4	3,6	4,0	10,3	10,6	8,7	--	--	--
	10.200	-3,3	8,5	11,0	23,1	7,7	19,8	7,9	20,0	22,5	34,6	5,0	3,2	4,8	5,8	14,8	15,2	12,5	--	--	--
0160	7.000	-1,8	4,7	6,6	14,8	4,8	13,0	5,4	13,6	15,4	23,7	2,7	1,8	2,8	2,7	7,8	7,6	6,3	--	--	--
	8.750	-2,4	6,7	8,9	19,2	6,5	16,8	6,8	17,1	19,3	29,6	3,9	2,6	4,0	4,3	12,2	11,8	9,9	--	--	--
	10.500	-3,5	8,9	11,4	23,9	7,9	20,3	8,2	20,6	23,1	35,6	5,3	3,5	5,3	6,2	17,5	17,0	14,2	--	--	--
0180	7.200	-1,8	5,0	6,8	15,3	5,0	13,5	5,5	14,0	15,9	24,4	2,9	1,9	2,9	2,9	8,0	7,8	6,8	--	--	--
	9.000	-2,5	7,0	9,2	19,9	6,7	17,4	7,0	17,6	19,9	30,5	4,1	2,7	4,1	4,5	12,5	12,2	10,6	--	--	--
	10.800	-3,8	9,3	11,9	24,7	8,1	20,9	8,4	21,2	23,8	36,7	5,5	3,6	5,5	6,5	18,0	17,5	15,2	--	--	--
0190	7.200	-1,8	5,0	6,8	15,3	5,0	13,5	5,5	14,0	15,9	24,4	2,9	1,9	2,9	2,9	8,0	7,8	6,8	--	--	--
	9.000	-2,5	7,0	9,2	19,9	6,7	17,4	7,0	17,6	19,9	30,5	4,1	2,7	4,1	4,5	12,5	12,2	10,6	--	--	--
	10.800	-3,8	9,3	11,9	24,7	8,1	20,9	8,4	21,2	23,8	36,7	5,5	3,6	5,5	6,5	18,0	17,5	15,2	--	--	--
0200	9.600	-1,7	4,5	6,2	14,1	4,5	12,4	5,1	13,0	14,8	22,7	2,6	1,2	2,4	3,1	--	--	--	6,4	6,2	--
	12.000	-2,2	6,3	8,4	18,3	6,2	16,1	6,5	16,4	18,5	28,4	3,7	1,6	3,4	4,8	--	--	--	10,1	9,7	--
	14.400	-3,2	8,3	10,8	22,7	7,6	19,5	7,8	19,8	22,2	34,2	4,9	2,2	4,6	6,9	--	--	--	14,5	13,9	--
0220	10.000	-1,8	4,7	6,6	14,8	4,8	13,0	5,4	13,6	15,4	23,7	2,7	1,2	2,5	3,3	--	--	--	7,1	6,4	--
	12.500	-2,4	6,7	8,9	19,2	6,5	16,8	6,8	17,1	19,3	29,6	3,9	1,7	3,6	5,2	--	--	--	11,1	10,1	--
	15.000	-3,5	8,9	11,4	23,9	7,9	20,3	8,2	20,6	23,1	35,6	5,3	2,3	4,9	7,5	--	--	--	16,0	14,5	--
0240	10.000	-1,8	4,7	6,6	14,8	4,8	13,0	5,4	13,6	15,4	23,7	2,7	1,2	2,5	3,3	--	--	--	7,1	6,4	--
	12.500	-2,4	6,7	8,9	19,2	6,5	16,8	6,8	17,1	19,3	29,6	3,9	1,7	3,6	5,2	--	--	--	11,1	10,1	--
	15.000	-3,5	8,9	11,4	23,9	7,9	20,3	8,2	20,6	23,1	35,6	5,3	2,3	4,9	7,5	--	--	--	16,0	14,5	--
0280	12.400	-1,8	4,6	6,4	14,5	4,6	12,7	5,3	13,3	15,1	23,2	2,7	1,2	2,6	3,1	--	--	--	--	4,6	6,7
	15.500	-2,3	6,5	8,6	18,7	6,3	16,5	6,6	16,7	18,9	29,0	3,8	1,7	3,7	4,9	--	--	--	--	7,2	10,5
	18.600	-3,4	8,6	11,1	23,3	7,7	19,9	8,0	20,2	22,7	34,9	5,1	2,3	5,0	7,0	--	--	--	--	10,4	15,1
0320	12.400	-1,8	4,6	6,4	14,5	4,6	12,7	5,3	13,3	15,1	23,2	2,7	1,2	2,6	3,1	--	--	--	--	4,6	6,7
	15.500	-2,3	6,5	8,6	18,7	6,3	16,5	6,6	16,7	18,9	29,0	3,8	1,7	3,7	4,9	--	--	--	--	7,2	10,5
	18.600	-3,4	8,6	11,1	23,3	7,7	19,9	8,0	20,2	22,7	34,9	5,1	2,3	5,0	7,0	--	--	--	--	10,4	15,1
0360	12.800	-1,8	4,8	6,7	15,0	4,9	13,2	5,4	13,7	15,6	23,9	2,8	1,3	2,7	3,3	--	--	--	--	4,9	7,1
	16.000	-2,4	6,8	9,0	19,4	6,6	17,0	6,9	17,3	19,5	30,0	4,0	1,8	3,9	5,2	--	--	--	--	7,6	11,1
	19.200	-3,6	9,1	11,6	24,2	7,9	20,6	8,2	20,9	23,4	36,0	5,4	2,4	5,2	7,5	--	--	--	--	11,0	15,9
0380	12.800	-1,8	4,8	6,7	15,0	4,9	13,2	5,4	13,7	15,6	23,9	2,8	1,3	3,0	3,3	--	--	--	--	4,9	7,1
	16.000	-2,4	6,8	9,0	19,4	6,6	17,0	6,9	17,3	19,5	30,0	4,0	1,8	4,3	5,2	--	--	--	--	7,6	11,1
	19.200	-3,6	9,1	11,6	24,2	7,9	20,6	8,2	20,9	23,4	36,0	5,4	2,4	5,8	7,5	--	--	--	--	11,0	15,9

① The pressure drops in the filters are based on clean filters. Data refer to the difference with regard to the G4 pressure drops (standard), considered as part of the machine pressure drops.

② The pressure drops in the stop-drops of the fresh air intake are based on 20% of flow.

Abbreviations:

- l.p.d. = low pressure drop
- H.W.C. = hot water coil
- E.H. = electrical heaters

**DIMENSIONAL DRAWINGS: RPJ SERIES**

**RPJ - 0090 / 0120 / 0140 / 0160 / 0180 / 0190, C0 and CS assemblies**

- ➔ Outdoor air circulation
  - ➔ Standard indoor air circulation
  - ⚠ Electrical cabinet
  - ⚡ Electric power supply
  - 🚪 Door switch
  - ⑥ Lower air supply
  - ⑦ Lateral air supply
  - ⑧ Lower air return
  - ⑨ Lateral air return
  - ⑩ Fresh air intake (CS assembly)
  - ⑫ Condensate outlet 1/2"M
  - ⑬ HWC connections (option)
- Anti-vibration anchoring: rivet nut M12



Vectios™ PJ

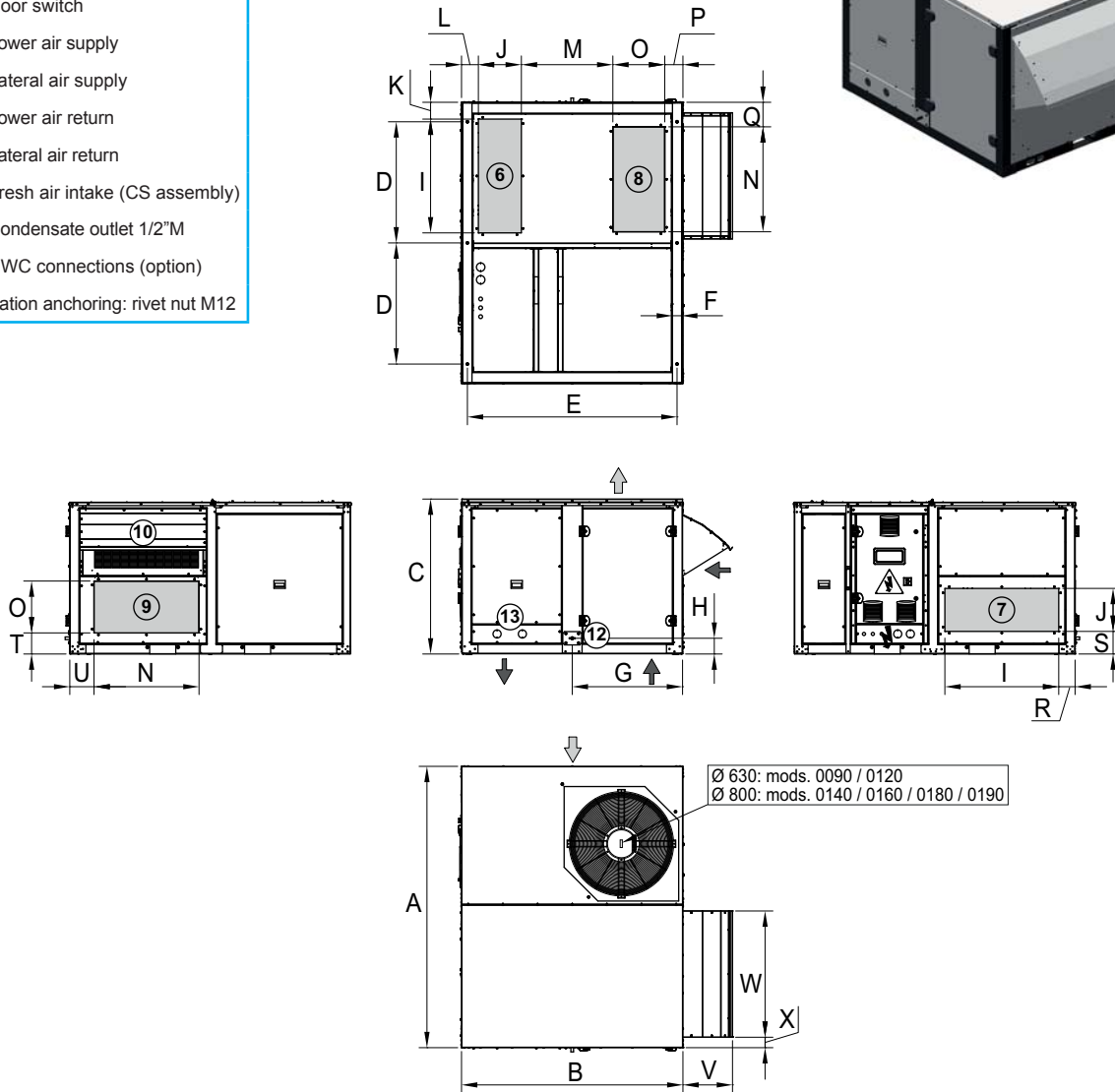

Dimensions	L x W x H			Supply										Return										
	A	B	C	D	E	F	G	H	I	J	K	L	M	N	O	P	Q	R	S	T	U	V	W	X
0090 to 0190 (mm)	2.225	1.750	1.230	958	1.657	72	872	125	900	340	133	133	723	830	410	144	194	129	179	167	191	392	998	83

Note: Drawings without scale. Refer to the certified dimensional drawings available on request, when designing an installation.

**DIMENSIONAL DRAWINGS: RPJ SERIES**

**RPJ - 0200 / 0220 / 0240 / 0280 / 0320 / 0360 / 0380, C0 and CS assemblies**

- ➔ Outdoor air circulation
  - ➔ Standard indoor air circulation
  - ⚠ Electrical cabinet
  - ⚡ Electric power supply
  - 🚪 Door switch
  - ⑥ Lower air supply
  - ⑦ Lateral air supply
  - ⑧ Lower air return
  - ⑨ Lateral air return
  - ⑩ Fresh air intake (CS assembly)
  - ⑫ Condensate outlet 1/2" M
  - ⑬ HWC connections (option)
- Anti-vibration anchoring: rivet nut M12

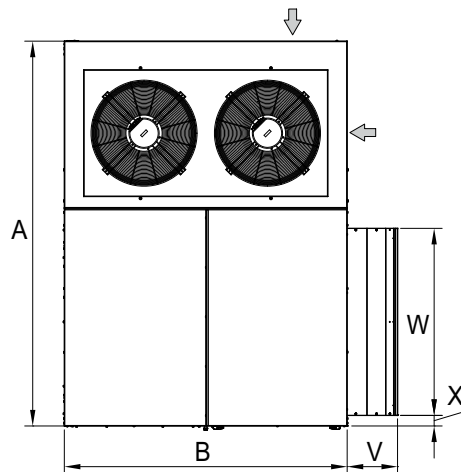
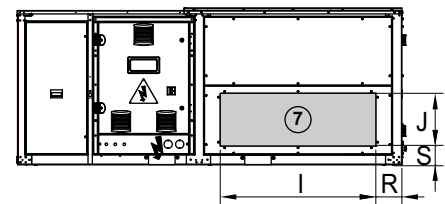
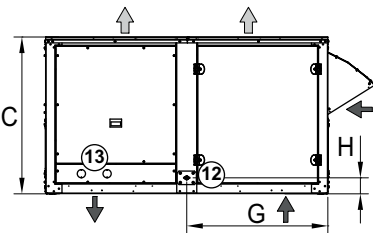
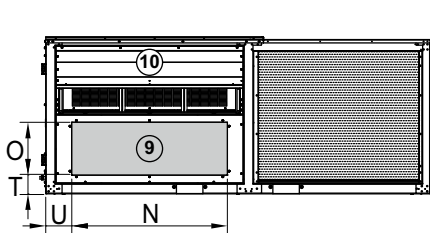
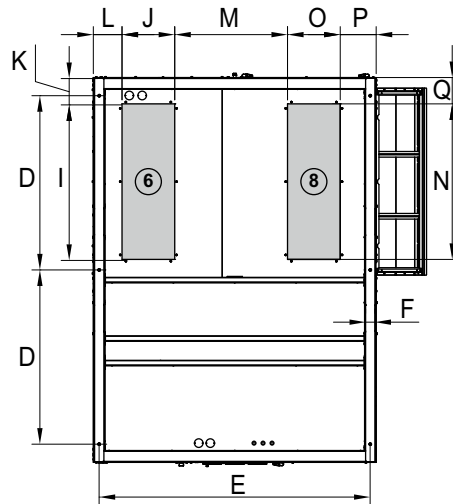

Dimensions	L x W x H			Supply										Return										
	A	B	C	D	E	F	G	H	I	J	K	L	M	N	O	P	Q	R	S	T	U	V	W	X
<b>0200 to 0240 (mm)</b>	3.000	2.200	1.230	1.356	2.108	72	1.098	125	1.210	410	205	223	877	1.210	410	279	205	203	147	147	203	392	1.455	82
<b>0280 to 0380 (mm)</b>	3.650	2.200	1.230	1.683	2.108	72	1.098	125	1.510	410	245	223	877	1.510	410	279	245	243	147	147	243	392	1.835	82

Note: Drawings without scale. Refer to the certified dimensional drawings available on request, when designing an installation.



**DIMENSIONAL DRAWINGS: RPJ SERIES**

**RPJ - 0090 / 0120 / 0140 / 0160 / 0180 / 0190, CK, CA, CP and CR assemblies**

- ➔ Outdoor air circulation
  - ➔ Standard indoor air circulation
  - ⚠ Electrical cabinet
  - ⚡ Electric power supply
  - ⏻ Door switch
  - ⑥ Lower air supply
  - ⑦ Lateral air supply
  - ⑧ Lower air return
  - ⑩ Fresh air intake
  - ⑪ Exhaust air outlet
  - ⑫ Condensate outlet 1/2"M
  - ⑬ HWC connections (option)
  - ⑳ Recovery circuit condensate outlet 1/2"M (CR assembly)
- Anti-vibration anchoring: rivet nut M12

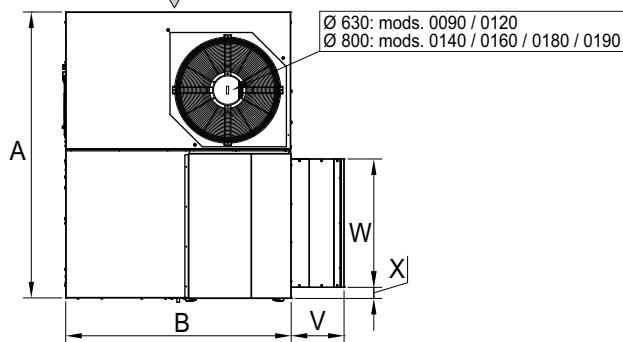
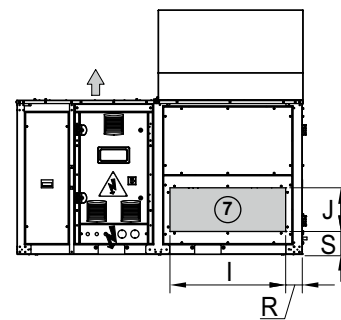
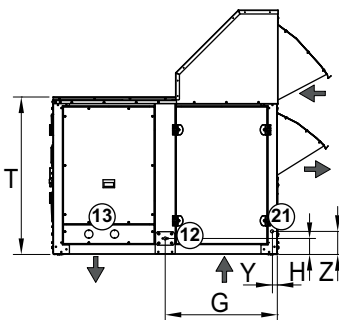
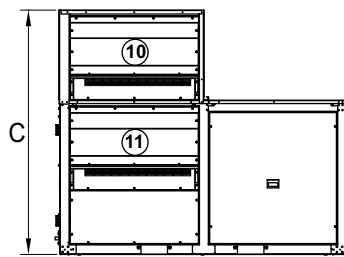
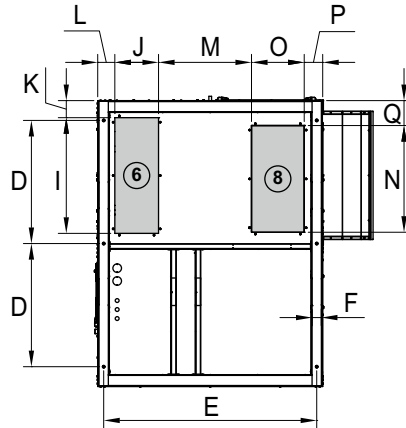

Dimensions	L x W x H			D	E	F	G	H	Supply					Return											
	A	B	C						I	J	K	L	M	N	O	P	Q	R	S	T	V	W	X	Y	Z
<b>0090 to 0190 (mm)</b>	2.230	1.755	1.905	958	1.657	72	872	125	900	340	133	133	723	830	410	144	194	129	179	1.230	410	998	86	45	174

Note: Drawings without scale. Refer to the certified dimensional drawings available on request, when designing an installation.

**DIMENSIONAL DRAWINGS: RPJ SERIES**

**RPJ - 0200 / 0220 / 0240 / 0280 / 0320 / 0360 / 0380, CK, CA, CP and CR assemblies**

- Outdoor air circulation
  - Standard indoor air circulation
  - ⚠ Electrical cabinet
  - ⚡ Electric power supply
  - 🚪 Door switch
  - ⑥ Lower air supply
  - ⑦ Lateral air supply
  - ⑧ Lower air return
  - ⑩ Fresh air intake
  - ⑪ Exhaust air outlet
  - ⑫ Condensate outlet 1/2"M
  - ⑬ HWC connections (option)
  - ⑳ Recovery circuit condensate outlet 1/2"M (CR assembly)
- Anti-vibration anchoring: rivet nut M12

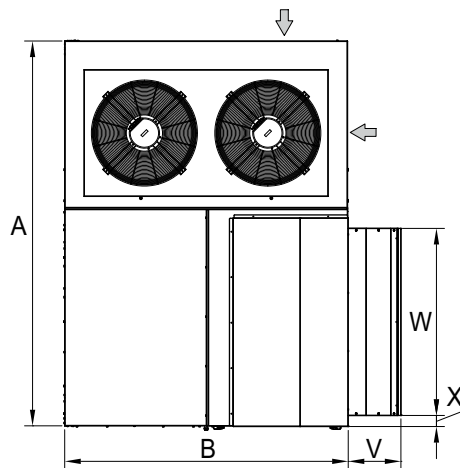
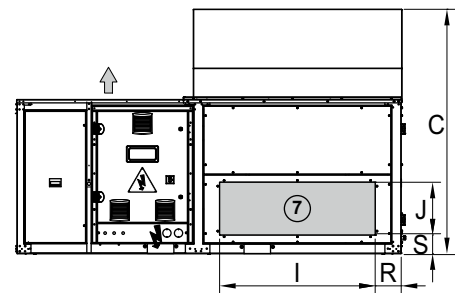
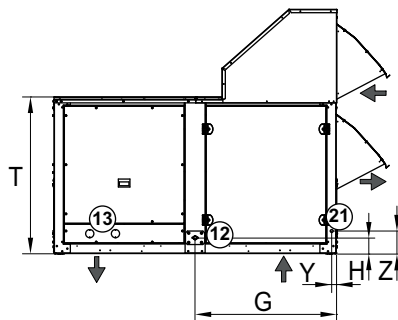
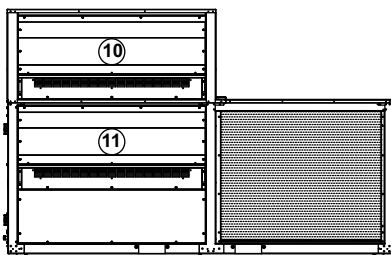
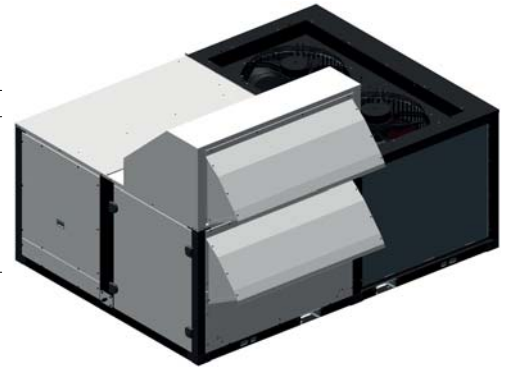
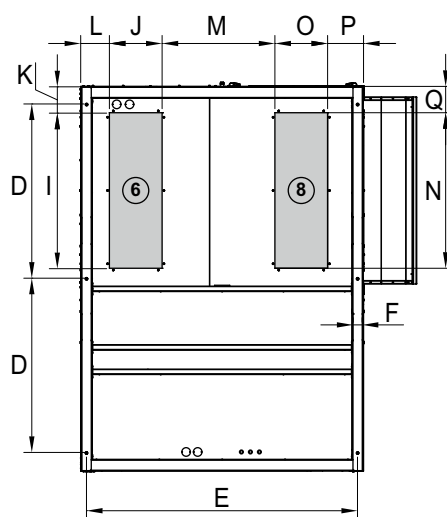

Dimensions	L x W x H			Supply										Return											
	A	B	C	D	E	F	G	H	I	J	K	L	M	N	O	P	Q	R	S	T	V	W	X	Y	Z
<b>0200 to 0240 (mm)</b>	3.000	2.205	1.905	1.356	2.108	72	1.098	125	1.210	410	205	223	877	1.210	410	279	205	203	147	1.230	410	1.455	86	45	174
<b>0280 to 0380 (mm)</b>	3.655	2.205	1.905	1.683	2.108	72	1.098	125	1.510	410	245	223	877	1.510	410	279	245	243	147	1.230	410	1.835	86	45	174

Note: Drawings without scale. Refer to the certified dimensional drawings available on request, when designing an installation.

**DIMENSIONAL DRAWINGS: RPJ SERIES**

**RPJ - 0090 / 0120 / 0140 / 0160 / 0180 / 0190, CQ and CT assemblies**

- ➔ Outdoor air circulation
  - ➔ Standard indoor air circulation
  - ⚠ Electrical cabinet
  - ⚡ Electric power supply
  - 🚪 Door switch
  - ⑥ Lower air supply
  - ⑦ Lateral air supply
  - ⑨ Lateral air return
  - ⑩ Fresh air intake
  - ⑪ Exhaust air outlet
  - ⑫ Condensate outlet 1/2" M
  - ⑬ HWC connections (option)
  - ⑳ Recovery circuit condensate outlet 1/2" M (CT assembly)
- Anti-vibration anchoring: rivet nut M12

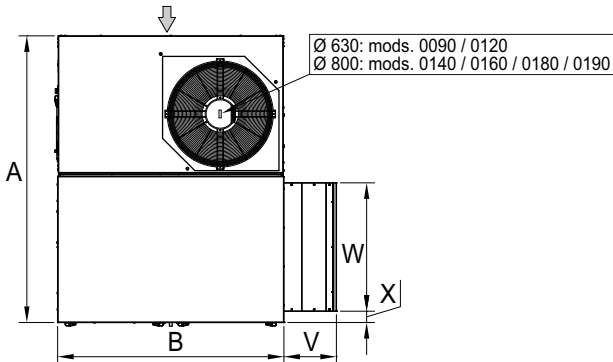
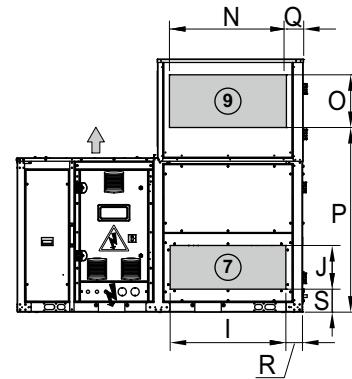
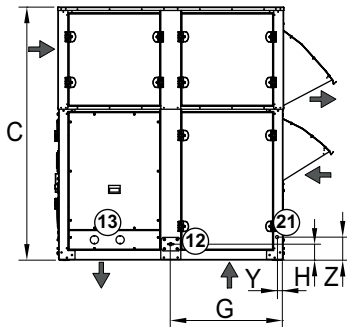
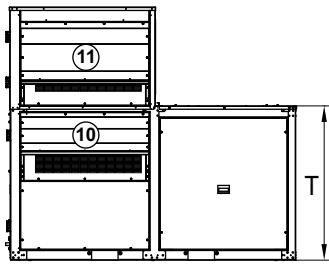
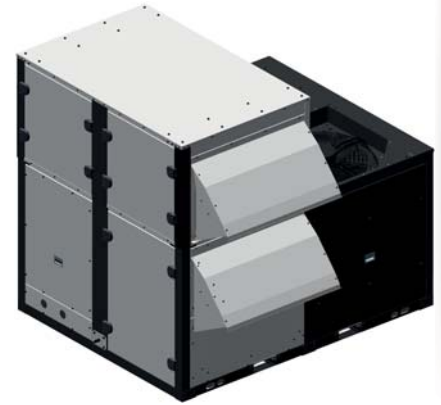
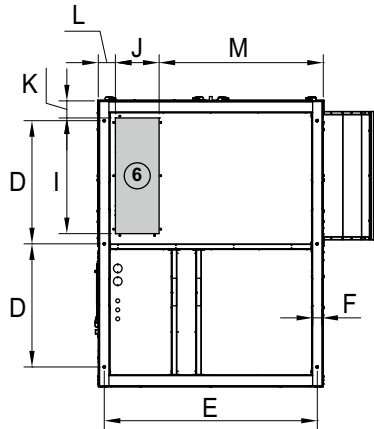

Dimensions	L x W x H			Supply										Return											
	A	B	C	D	E	F	G	H	I	J	K	L	M	N	O	P	Q	R	S	T	V	W	X	Y	Z
<b>0090 to 0190 (mm)</b>	2.230	1.760	1.975	958	1.657	72	872	125	900	340	133	133	1.277	910	410	1.436	133	129	179	1.200	410	998	88	45	174

Note: Drawings without scale. Refer to the certified dimensional drawings available on request, when designing an installation.

**DIMENSIONAL DRAWINGS: RPJ SERIES**

**RPJ - 0200 / 0220 / 0240 / 0280 / 0320 / 0360 / 0380, CQ and CT assemblies**

- ➔ Outdoor air circulation
  - ➔ Standard indoor air circulation
  - ⚠ Electrical cabinet
  - ⚡ Electric power supply
  - 🚪 Door switch
  - ⑥ Lower air supply
  - ⑦ Lateral air supply
  - ⑨ Lateral air return
  - ⑩ Fresh air intake
  - ⑪ Exhaust air outlet
  - ⑫ Condensate outlet 1/2"M
  - ⑬ HWC connections (option)
  - ⑳ Recovery circuit condensate outlet 1/2"M (CT assembly)
- Anti-vibration anchoring: rivet nut M12

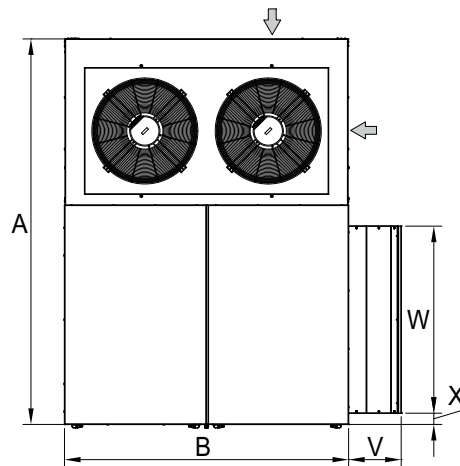
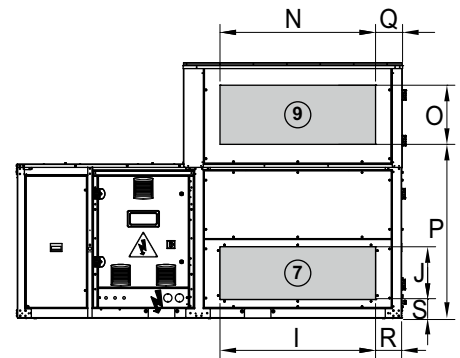
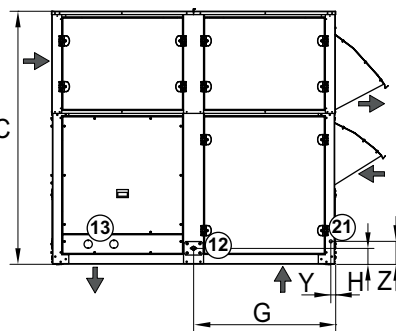
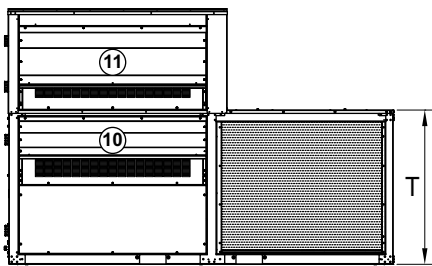
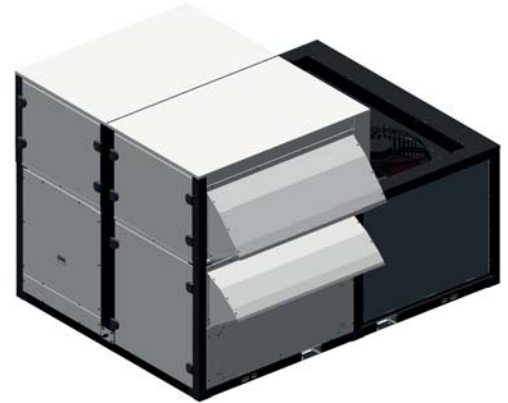
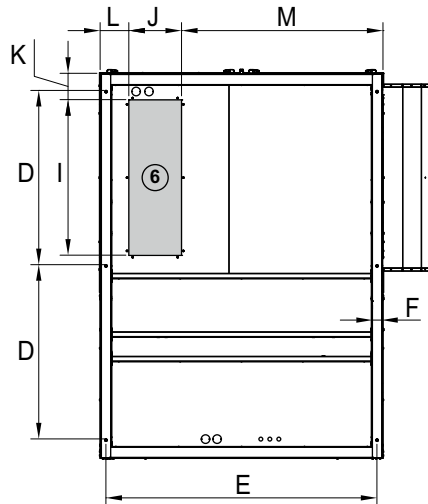

Dimensions	L x W x H			Supply										Return											
	A	B	C	D	E	F	G	H	I	J	K	L	M	N	O	P	Q	R	S	T	V	W	X	Y	Z
<b>0200 to 0240 (mm)</b>	3.000	2.210	1.995	1.356	2.108	72	1.098	125	1.210	410	205	223	1.567	1.210	460	1.353	210	203	147	1.200	410	1.455	88	45	174
<b>0280 to 0380 (mm)</b>	3.655	2.210	1.995	1.683	2.108	72	1.098	125	1.510	410	245	223	1.567	1.210	460	1.353	400	243	147	1.200	410	1.835	88	45	174

Note: Drawings without scale. Refer to the certified dimensional drawings available on request, when designing an installation.

## DIMENSIONAL DRAWINGS: RPJ SERIES

### RPJ - 0090 / 0120 / 0140 / 0160 / 0180 / 0190, montage CW assembly

- ➔ Outdoor air circulation
  - ➔ Standard indoor air circulation
  - ⚠ Electrical cabinet
  - ⚡ Electric power supply
  - ⏻ Door switch
  - ⑥ Lower air supply
  - ⑦ Lateral air supply
  - ⑧ Lower air return
  - ⑩ Fresh air intake
  - ⑪ Exhaust air outlet
  - ⑫ Condensate outlet 1/2"M
  - ⑬ HWC connections (option)
  - ⑭ Wheel condensate outlet 1/2"M
- Anti-vibration anchoring: rivet nut M12

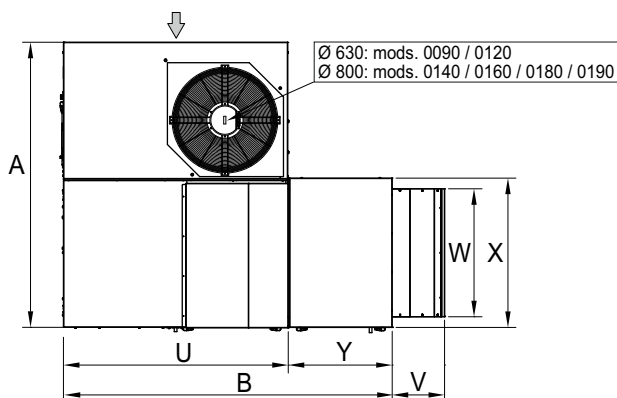
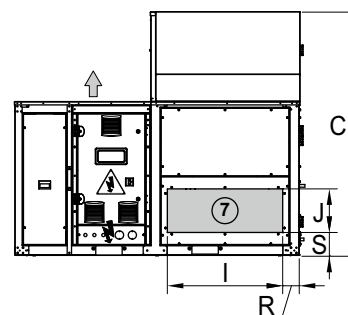
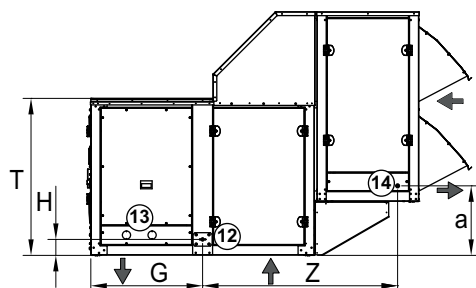
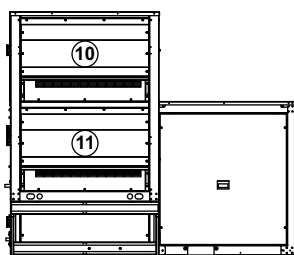
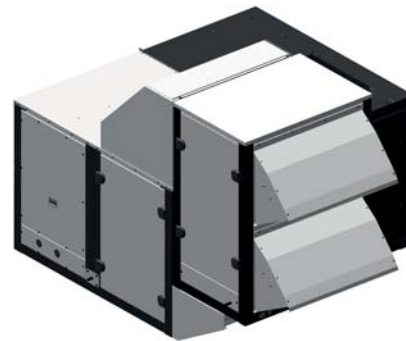
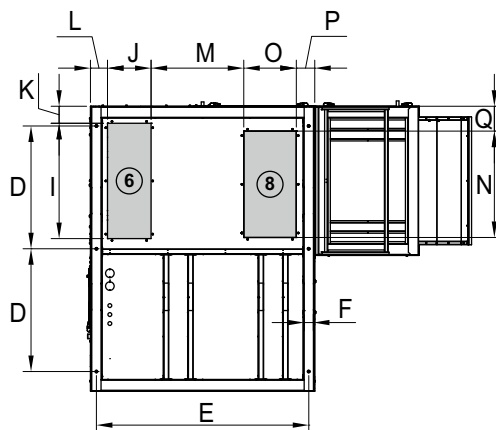

Dimensions	L x W x H			Supply											Return					a							
	A	B	C	D	E	F	G	H	I	J	K	L	M	N	O	P	Q	R	S		T	U	V	W	X	Y	Z
0090 to 0190 (mm)	2.230	2.565	1.905	958	1.657	72	872	125	900	340	133	133	723	830	410	144	194	129	179	1.230	1.755	410	998	1.165	810	1.521	543

Note: Drawings without scale. Refer to the certified dimensional drawings available on request, when designing an installation.

**DIMENSIONAL DRAWINGS: RPJ SERIES**

**RPJ - 0200 / 0220 / 0240 / 0280 / 0320 / 0360 / 0380, CW assembly**

- ➔ Outdoor air circulation
  - ➔ Standard indoor air circulation
  - ⚠ Electrical cabinet
  - ⚡ Electric power supply
  - 🚪 Door switch
  - ⑥ Lower air supply
  - ⑦ Lateral air supply
  - ⑧ Lower air return
  - ⑩ Fresh air intake
  - ⑪ Exhaust air outlet
  - ⑫ Condensate outlet 1/2"M
  - ⑬ HWC connections (option)
  - ⑭ Wheel condensate outlet 1/2"M
- Anti-vibration anchoring: rivet nut M12

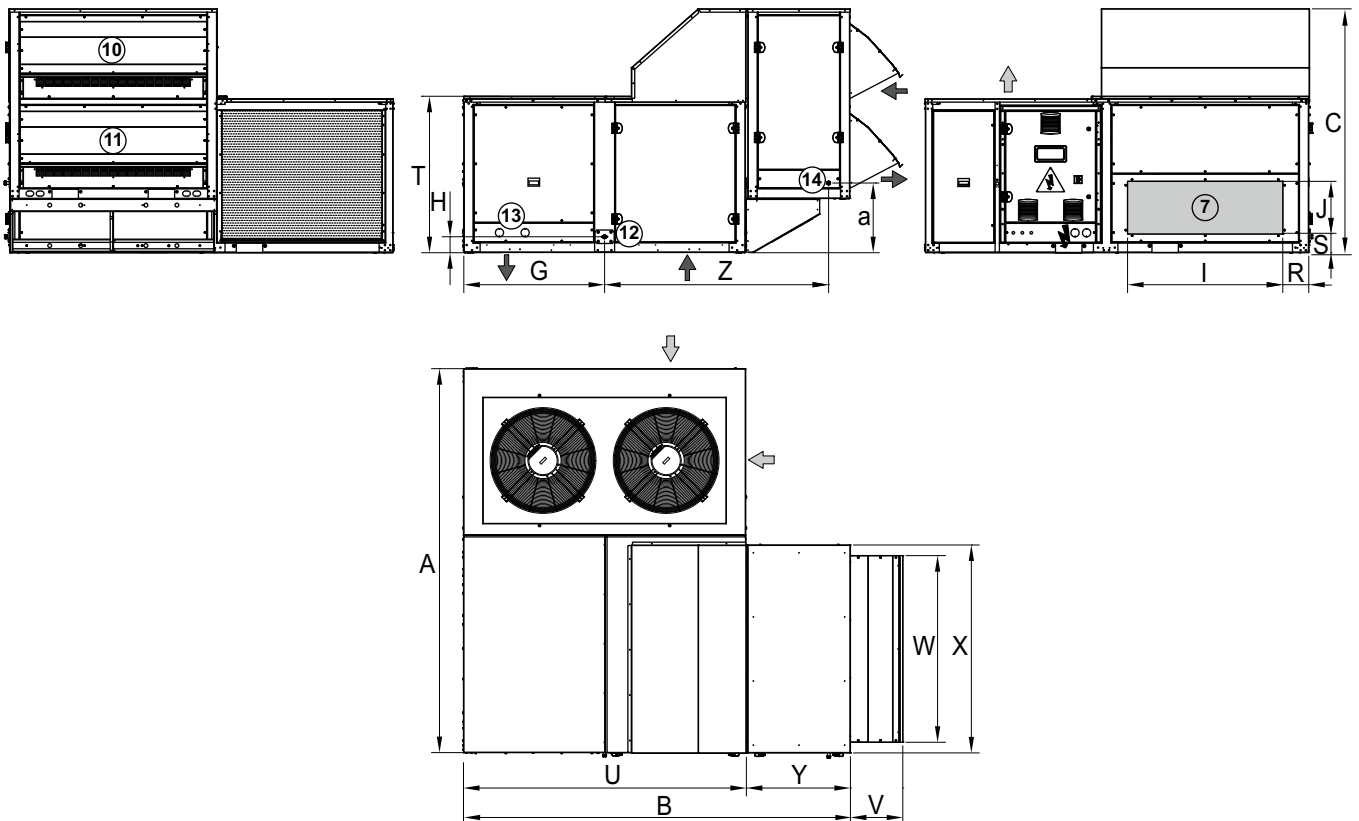
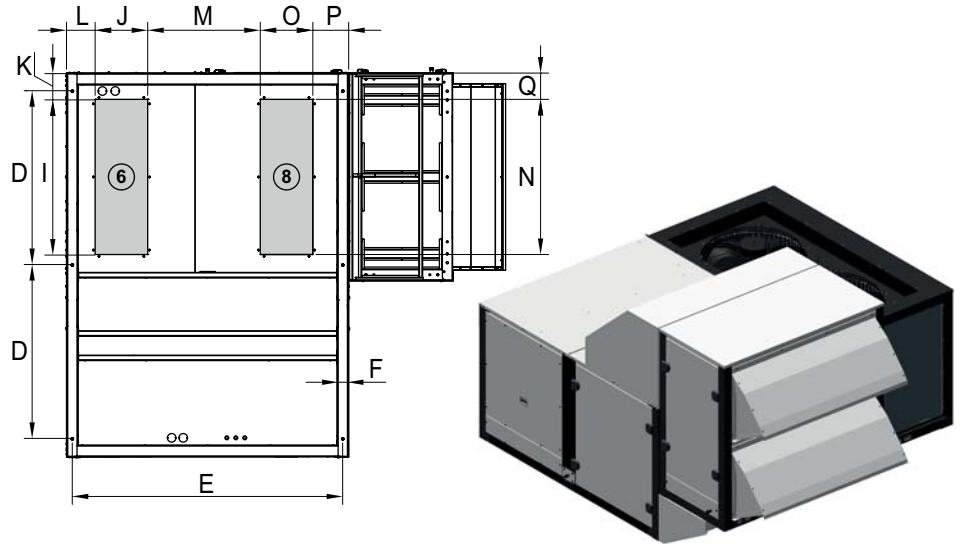

Dimensions	L x W x H			Supply											Return					a							
	A	B	C	D	E	F	G	H	I	J	K	L	M	N	O	P	Q	R	S		T	U	V	W	X	Y	Z
<b>0200 to 0240 (mm)</b>	3.000	3.015	1.905	1.356	2.108	72	1.098	125	1.210	410	205	223	877	1.210	410	279	205	203	147	1.230	2.205	410	1.455	1.621	810	1.746	544
<b>0280 to 0380 (mm)</b>	3.655	3.015	1.905	1.683	2.108	72	1.098	125	1.510	410	245	223	877	1.510	410	279	245	243	147	1.230	2.205	410	1.835	2.201	810	1.746	243

Note: Drawings without scale. Refer to the certified dimensional drawings available on request, when designing an installation.

**DIMENSIONAL DRAWINGS: RPJ SERIES**

**RPJ - 0200 / 0220 / 0240 / 0280 / 0320 / 0360 / 0380, T0 assembly**

- ➔ Outdoor air circulation
  - ➡ Standard indoor air circulation
  - ⚠ Electrical cabinet
  - ⚡ Electric power supply
  - 🚪 Door switch
  - ⑥ Lower air supply
  - ⑧ Lower air return
  - ⑨ Lateral air return
  - ⑫ Condensate outlet 1/2" M
  - ⑬ HWC connections (option)
- Anti-vibration anchoring: rivet nut M12



Vectios™ PJ

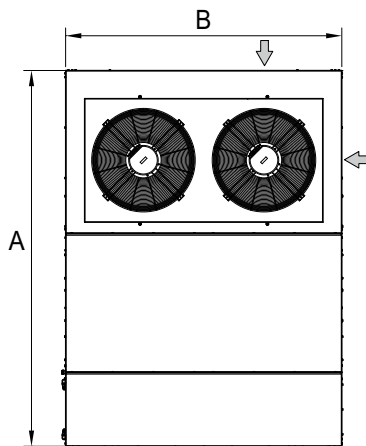
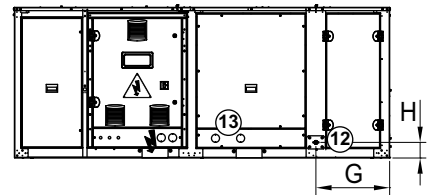
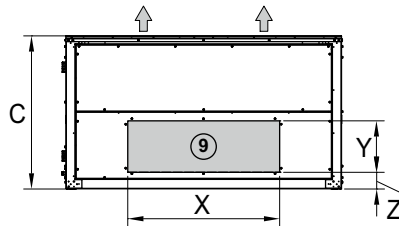
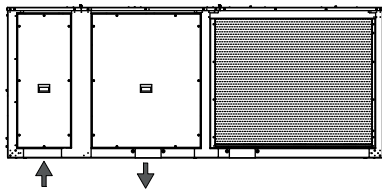
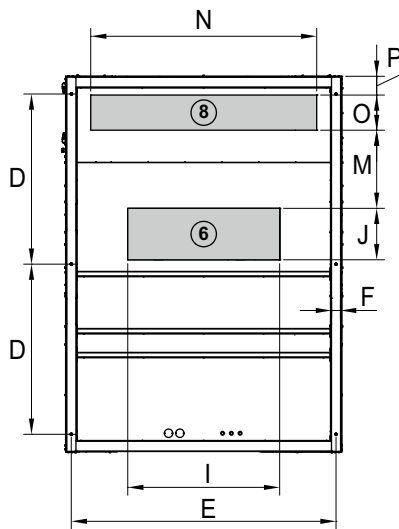

Dimensions	L x W x H								Supply			Return					
	A	B	C	D	E	F	G	H	I	J	M	N	O	P	X	Y	Z
0200 to 0240 (mm)	3.000	2.200	1.230	1.356	2.108	72	587	125	1.210	410	622	1.800	280	150	1.210	410	133
0280 to 0380 (mm)	3.650	2.200	1.230	1.683	2.108	72	967	125	1.510	410	774	1.510	410	248	1.510	410	147

Note: Drawings without scale. Refer to the certified dimensional drawings available on request, when designing an installation.

**DIMENSIONAL DRAWINGS: RPJ SERIES**

**RPJ - 0200 / 0220 / 0240, TS assembly**

- ➔ Outdoor air circulation
  - ➔ Standard indoor air circulation
  - ⚠ Electrical cabinet
  - ⚡ Electric power supply
  - 🚪 Door switch
  - ⑥ Lower air supply
  - ⑧ Lower air return
  - ⑨ Lateral air return
  - ⑩ Fresh air intake
  - ⑫ Condensate outlet 1/2" M
  - ⑬ HWC connections (option)
  - ⑮ Enclosure for lower return (on-site configuration)
- Anti-vibration anchoring: rivet nut M12

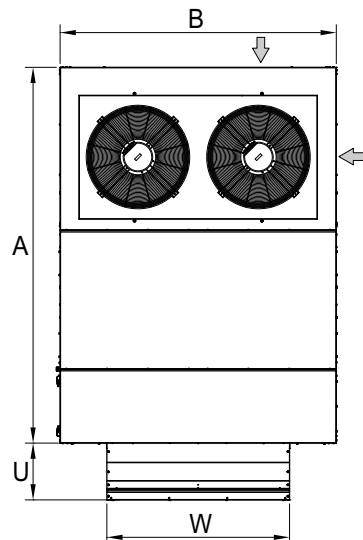
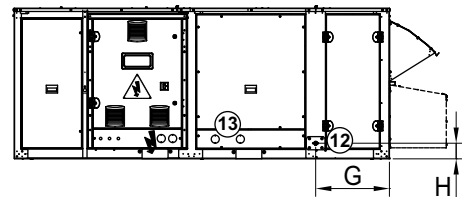
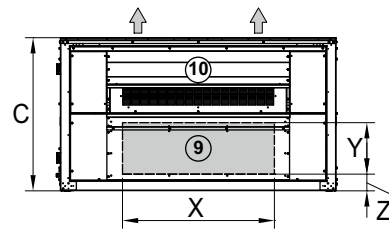
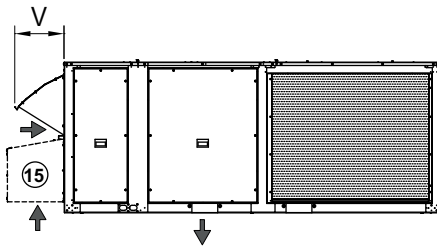
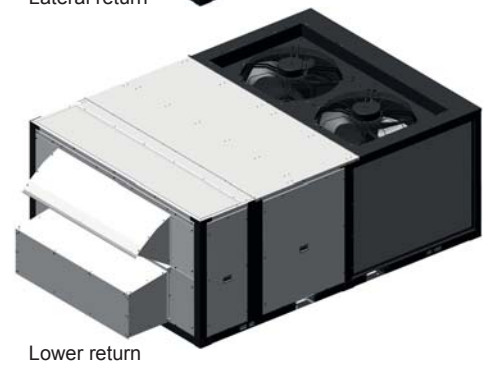
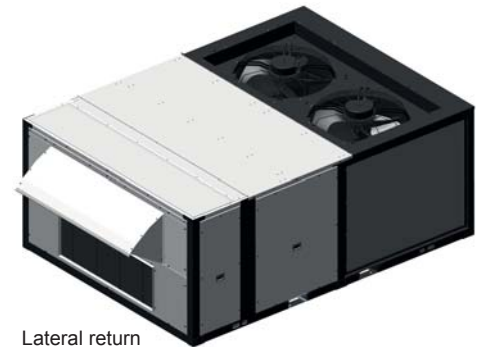
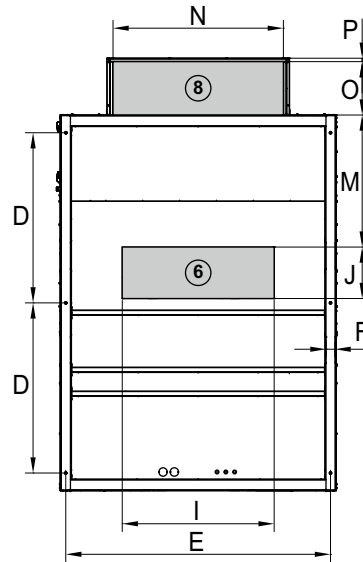

Dimensions	L x W x H										Supply		Return								
	A	B	C	D	E	F	G	H	I	J	M	N	O	P	U	V	W	X	Y	Z	
<b>0200 to 0240 (mm)</b>	3.000	2.200	1.230	1.356	2.108	72	587	125	1.210	410	1.052	1.357	125	27	452	392	1.455	1.210	410	133	

Note: Drawings without scale. Refer to the certified dimensional drawings available on request, when designing an installation.



**DIMENSIONAL DRAWINGS: RPJ SERIES**

**RPJ - 0280 / 0320 / 0360 / 0380, TS assembly**

- ➔ Outdoor air circulation
  - ➔ Indoor air circulation
  - ⚠ Electrical cabinet
  - ⚡ Electric power supply
  - ⏻ Door switch
  - ⑥ Lower air supply
  - ⑧ Lower air return
  - ⑨ Lateral air return
  - ⑩ Fresh air intake
  - ⑫ Condensate outlet 1/2" M
  - ⑬ HWC connections (option)
- Anti-vibration anchoring: rivet nut M12

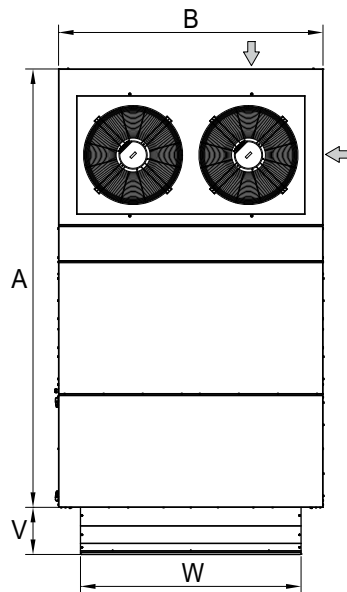
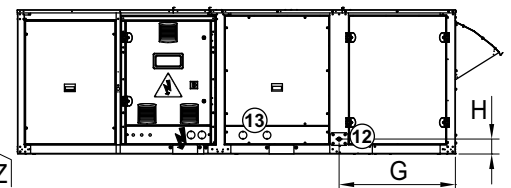
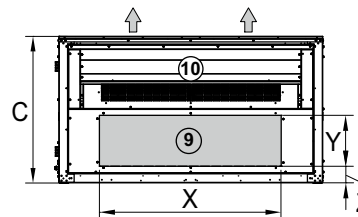
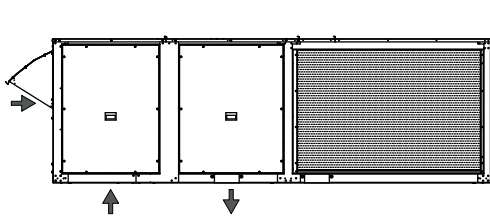
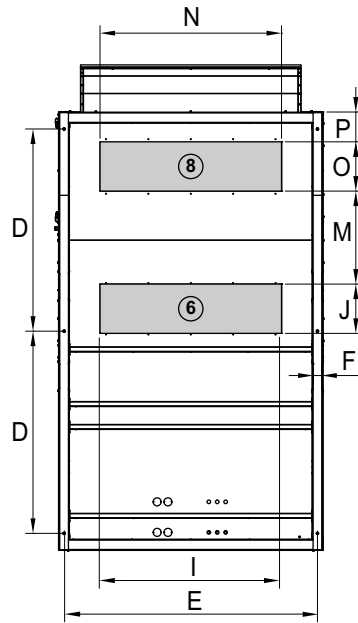

Dimensions	L x W x H			Supply							Return			V	W	X	Y	Z	
	A	B	C	D	E	F	G	H	I	J	M	N	O						P
0280 to 0380 (mm)	3.650	2.200	1.230	1.683	2.108	72	967	125	1.510	410	774	1.510	410	248	392	1.835	1.510	410	147

Note: Drawings without scale. Refer to the certified dimensional drawings available on request, when designing an installation.

**DIMENSIONAL DRAWINGS: RPJ SERIES**

**RPJ - 0200 / 0220 / 0240, TP assembly**

- ↔ Outdoor air circulation
  - Indoor air circulation
  - ⚠ Electrical cabinet
  - ⚡ Electric power supply
  - ⏻ Door switch
  - ⑥ Lower air supply
  - ⑧ Lower air return
  - ⑩ Fresh air intake
  - ⑪ Exhaust air outlet
  - ⑫ Condensate outlet 1/2" M
  - ⑬ HWC connections (option)
- Anti-vibration anchoring: rivet nut M12

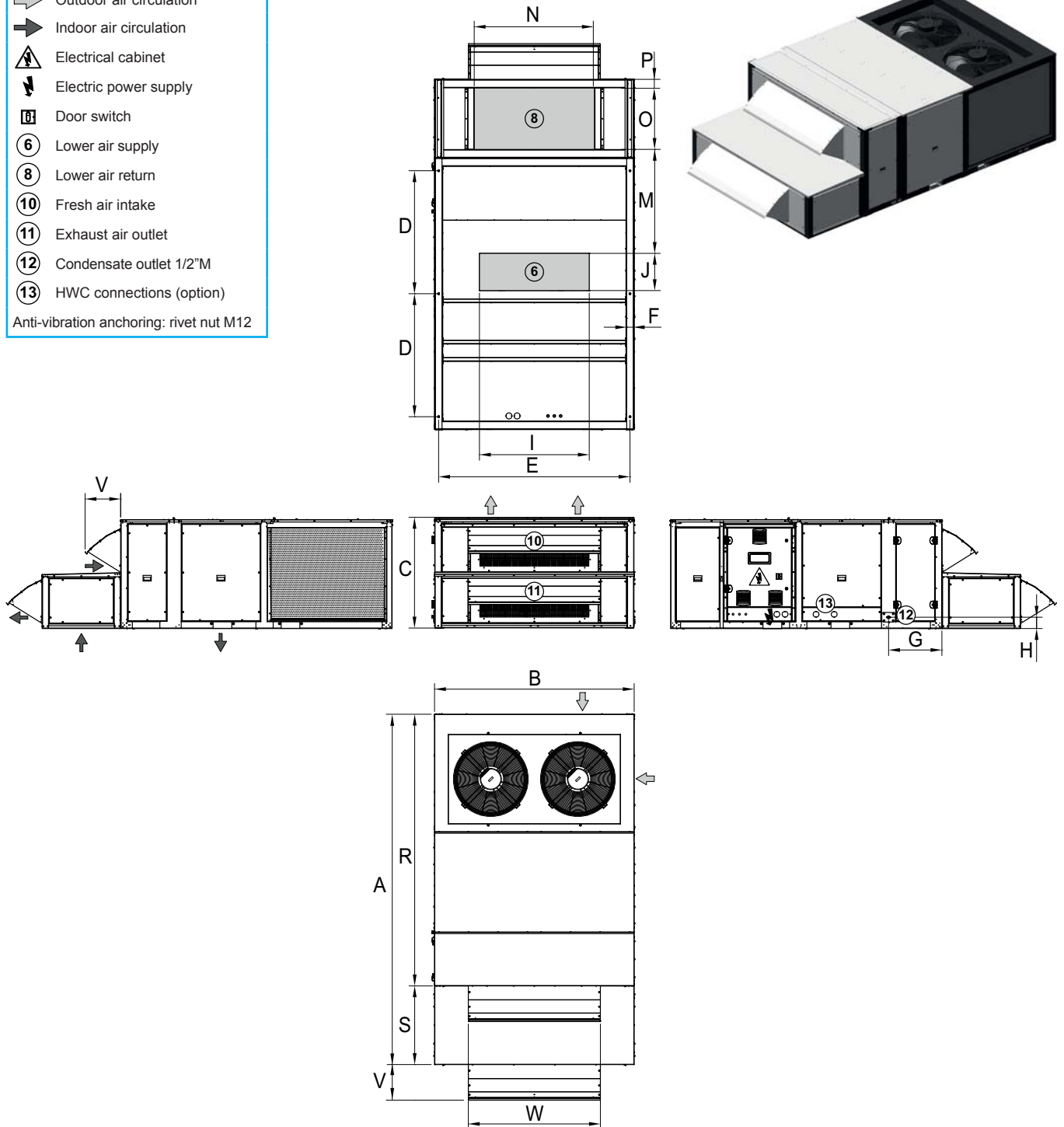

Dimensions	L x W x H			D	E	F	G	H	Supply		Return		P	R	S	V	W	
	A	B	C						I	J	M	N						O
<b>0200 to 0240 (mm)</b>	3.865	2.200	1.230	1.356	2.108	72	587	125	1.210	410	1.144	1.330	680	95	2.995	870	297	1.455

Note: Drawings without scale. Refer to the certified dimensional drawings available on request, when designing an installation.

## DIMENSIONAL DRAWINGS: RPJ SERIES

### RPJ - 0280 / 0320 / 0360 / 0380, TP assembly

- ➔ Outdoor air circulation
  - ➔ Indoor air circulation
  - ⚠ Electrical cabinet
  - ⚡ Electric power supply
  - ⑤ Door switch
  - ⑥ Lower air supply
  - ⑧ Lower air return
  - ⑩ Fresh air intake
  - ⑪ Exhaust air outlet
  - ⑫ Condensate outlet 1/2" M
  - ⑬ HWC connections (option)
- Anti-vibration anchoring: rivet nut M12

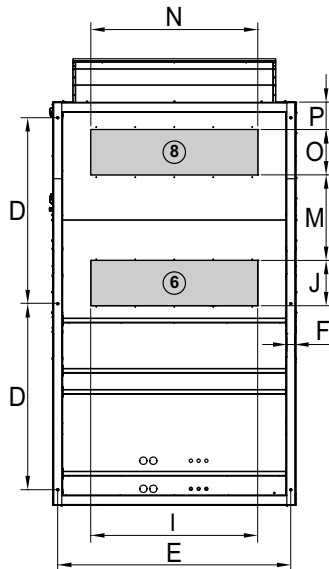

Vectios™ PJ

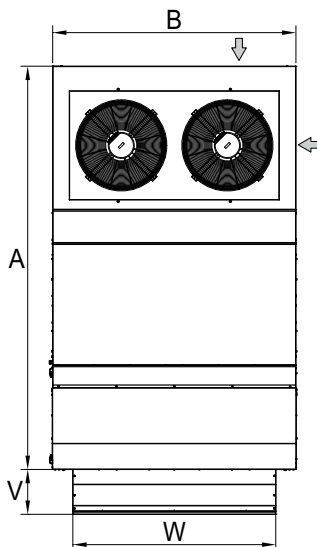
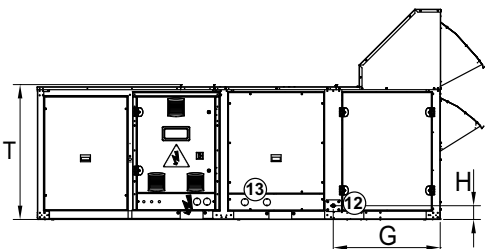
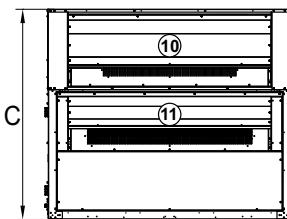
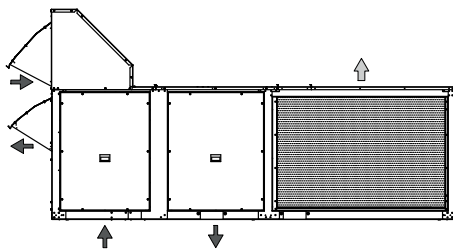

Dimensions	L x W x H			D	E	F	G	H	Supply			Return		P	T	V	W
	A	B	C						I	J	M	N	O				
0280 to 0380 (mm)	3.655	2.210	1.905	1.683	2.108	72	967	125	1.510	410	774	1.510	410	248	1.230	410	1.835

Note: Drawings without scale. Refer to the certified dimensional drawings available on request, when designing an installation.

**DIMENSIONAL DRAWINGS: RPJ SERIES**

**RPJ - 0200 / 0220 / 0240 / 0280 / 0320 / 0360 / 0380, TW assembly**

- ↔ Outdoor air circulation
  - Indoor air circulation
  - ⚠ Electrical cabinet
  - ⚡ Electric power supply
  - ⑤ Door switch
  - ⑥ Lower air supply
  - ⑧ Lower air return
  - ⑩ Fresh air intake
  - ⑪ Exhaust air outlet
  - ⑫ Condensate outlet 1/2" M
  - ⑬ HWC connections (option)
  - ⑭ Wheel condensate outlet 1/2" M
- Anti-vibration anchoring: rivet nut M12

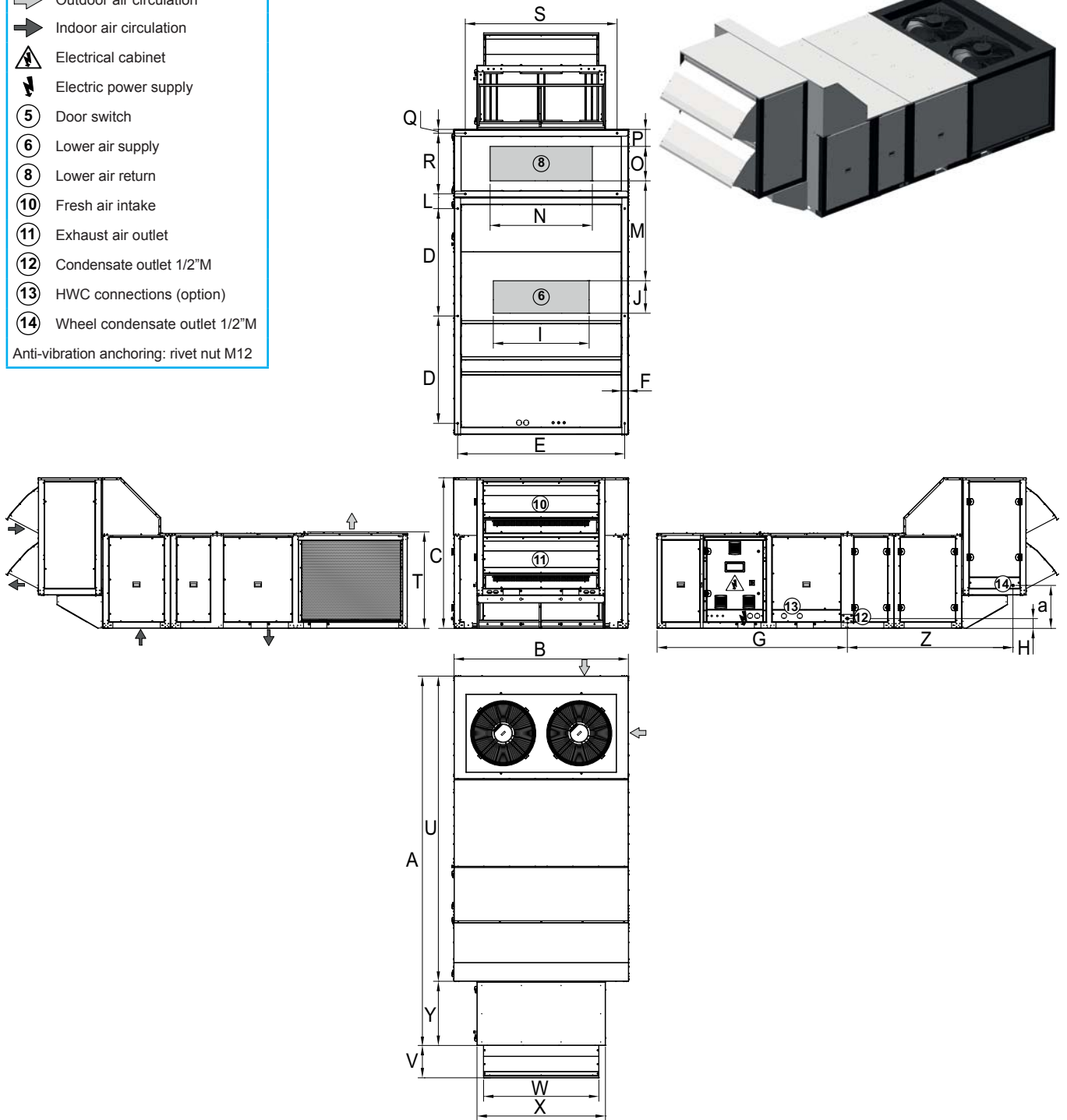
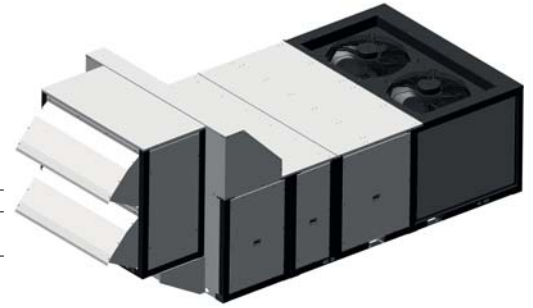

Dimensions	L x W x H			Supply								Return														
	A	B	C	D	E	F	G	H	I	J	L	M	N	O	P	Q	R	S	T	U	V	W	X	Y	Z	a
<b>0200 to 0240 (mm)</b>	4.675	2.210	1.905	1.356	2.108	72	2.402	125	1.210	410	196	1.271	1.290	435	215	48	766	1.916	1.230	3.865	410	1.455	1.621	810	2.100	544
<b>0280 to 0380 (mm)</b>	4.465	2.210	1.905	1.683	2.108	72	2.676	125	1.510	410	--	774	1.510	410	248	--	--	--	1.230	3.655	410	1.835	2.001	810	1.614	243

Note: Drawings without scale. Refer to the certified dimensional drawings available on request, when designing an installation.

**DIMENSIONAL DRAWINGS: IPJ SERIES**

**IPJ - 0090 / 0120 / 0140 / 0160 / 0180 / 0190, C0 and CS assemblies**

- ➔ Outdoor air circulation
  - ➔ Standard indoor air circulation
  - ⚠ Electrical cabinet
  - ⚡ Electric power supply
  - 🚪 Door switch
  - ⑥ Lower air supply
  - ⑦ Lateral air supply
  - ⑧ Lower air return
  - ⑨ Lateral air return
  - ⑩ Fresh air intake (CS assembly)
  - ⑫ Condensate outlet 1/2"M
  - ⑬ HWC connections (option)
- Anti-vibration anchoring: rivet nut M12



Vectios™ PJ

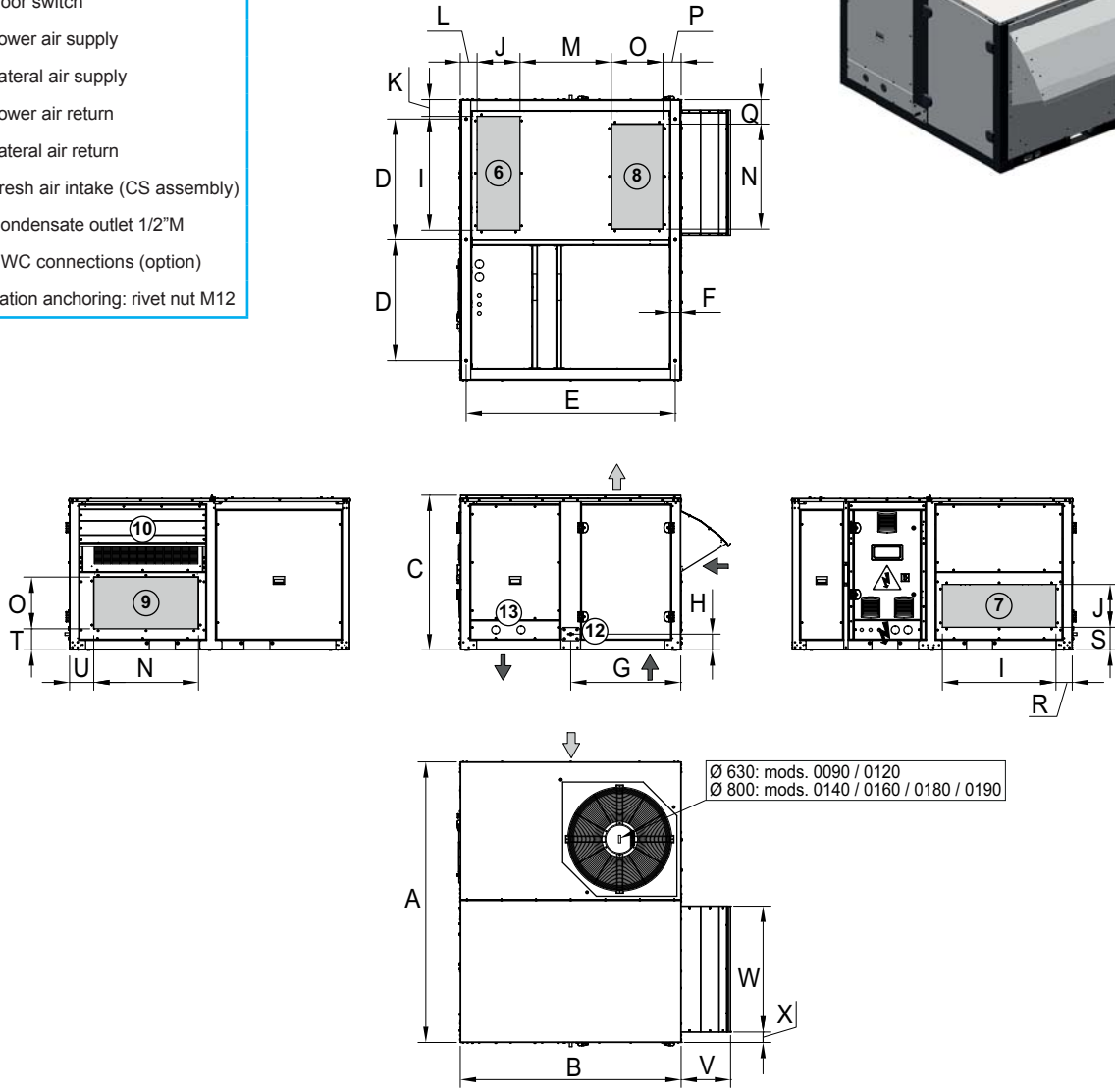

Dimensions	L x W x H			Supply											Return				P	Q	R	S	T	U	V	W	X
	A	B	C	D	E	F	G	H	I	J	K	L	M	N	O												
0090 to 0190 (mm)	2.225	1.750	1.230	958	1.657	72	872	125	900	340	133	133	723	830	410	144	194	129	179	167	191	392	998	83			

Note: Drawings without scale. Refer to the certified dimensional drawings available on request, when designing an installation.

**DIMENSIONAL DRAWINGS: IPJ SERIES**

**IPJ - 0200 / 0220 / 0240 / 0280 / 0320 / 0360 / 0380, C0 and CS assemblies**

- ➔ Outdoor air circulation
  - ➔ Standard indoor air circulation
  - ⚠ Electrical cabinet
  - ⚡ Electric power supply
  - ⑤ Door switch
  - ⑥ Lower air supply
  - ⑦ Lateral air supply
  - ⑧ Lower air return
  - ⑨ Lateral air return
  - ⑩ Fresh air intake (CS assembly)
  - ⑫ Condensate outlet 1/2" M
  - ⑬ HWC connections (option)
- Anti-vibration anchoring: rivet nut M12

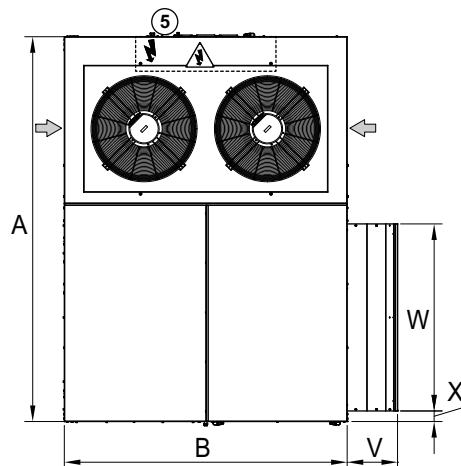
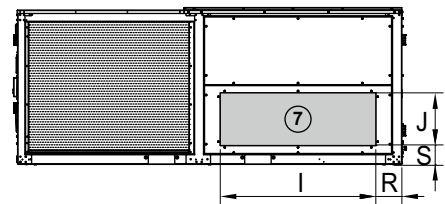
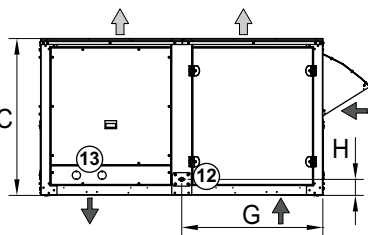
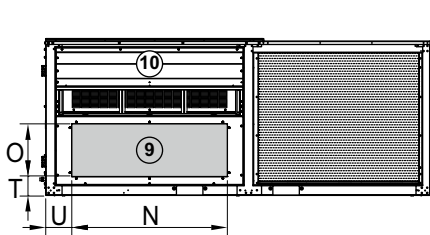
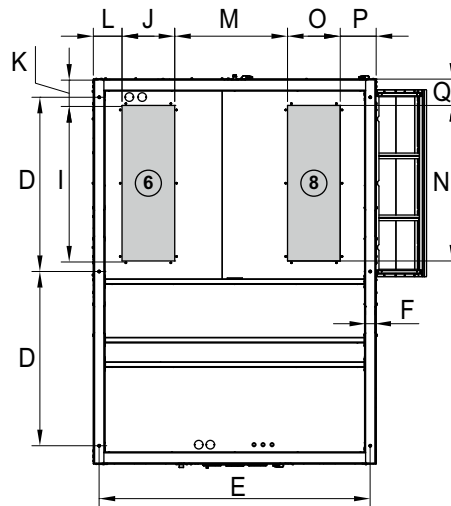

Dimensions	L x W x H			Supply													Return							
	A	B	C	D	E	F	G	H	I	J	K	L	M	N	O	P	Q	R	S	T	U	V	W	X
<b>0200 to 0240 (mm)</b>	3.000	2.200	1.230	1.356	2.108	72	1.098	125	1.210	410	205	223	877	1.210	410	279	205	203	147	147	203	392	1.455	82
<b>0280 to 0380 (mm)</b>	3.650	2.200	1.230	1.683	2.108	72	1.098	125	1.510	410	245	223	877	1.510	410	279	245	243	147	147	243	392	1.835	82

Note: Drawings without scale. Refer to the certified dimensional drawings available on request, when designing an installation.

**DIMENSIONAL DRAWINGS: IPJ SERIES**

**IPJ - 0090 / 0120 / 0140 / 0160 / 0180 / 0190, CK, CA, CP and CR assemblies**

- ➔ Outdoor air circulation
  - ➔ Standard indoor air circulation
  - ⚠ Electrical cabinet
  - ⚡ Electric power supply
  - ⏻ Door switch
  - ⑥ Lower air supply
  - ⑦ Lateral air supply
  - ⑧ Lower air return
  - ⑩ Fresh air intake
  - ⑪ Exhaust air outlet
  - ⑫ Condensate outlet 1/2"M
  - ⑬ HWC connections (option)
  - ⑳ Recovery circuit condensate outlet 1/2"M (CR assembly)
- Anti-vibration anchoring: rivet nut M12

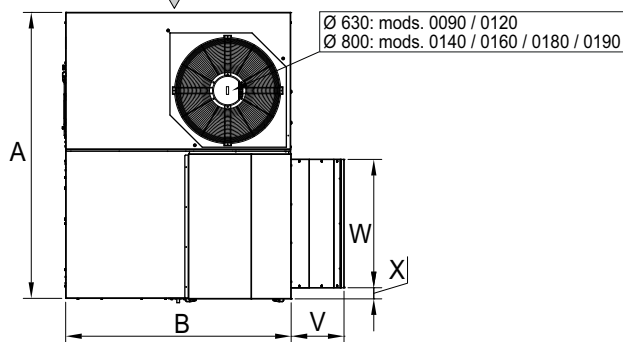
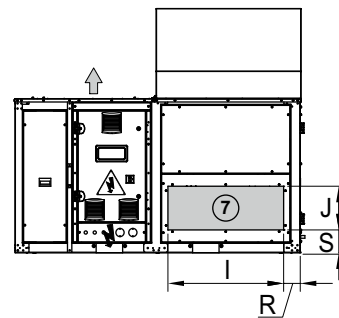
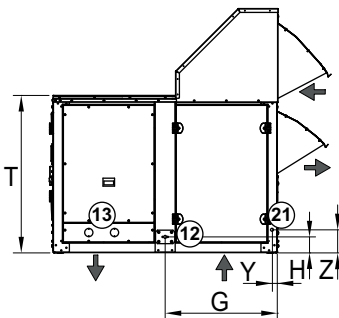
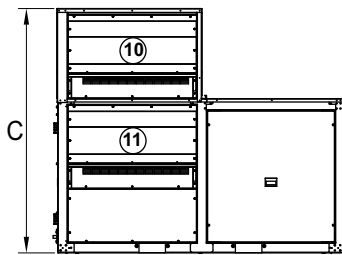
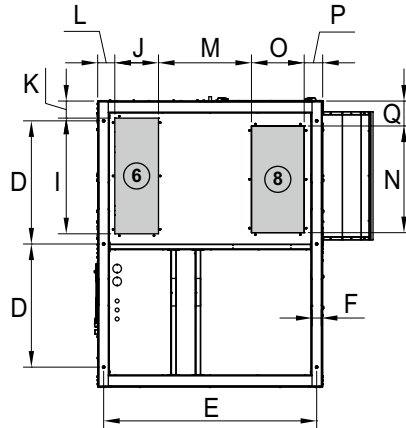

Dimensions	L x W x H			Supply													Return								
	A	B	C	D	E	F	G	H	I	J	K	L	M	N	O	P	Q	R	S	T	V	W	X	Y	Z
0090 to 0190 (mm)	2.230	1.755	1.905	958	1.657	72	872	125	900	340	133	133	723	830	410	144	194	129	179	1.230	410	998	86	45	174

Note: Drawings without scale. Refer to the certified dimensional drawings available on request, when designing an installation.

**DIMENSIONAL DRAWINGS: IPJ SERIES**

**IPJ - 0200 / 0220 / 0240 / 0280 / 0320 / 0360 / 0380, CK, CA, CP and CR assemblies**

- Outdoor air circulation
  - Standard indoor air circulation
  - ⚠ Electrical cabinet
  - ⚡ Electric power supply
  - ⑤ Door switch
  - ⑥ Lower air supply
  - ⑦ Lateral air supply
  - ⑧ Lower air return
  - ⑩ Fresh air intake
  - ⑪ Exhaust air outlet
  - ⑫ Condensate outlet 1/2"M
  - ⑬ HWC connections (option)
  - ⑳ Recovery circuit condensate outlet 1/2"M (CR assembly)
- Anti-vibration anchoring: rivet nut M12

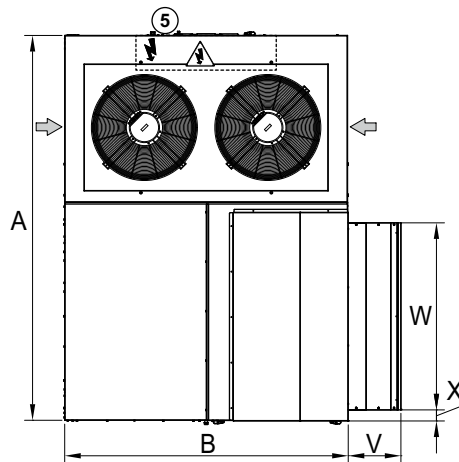
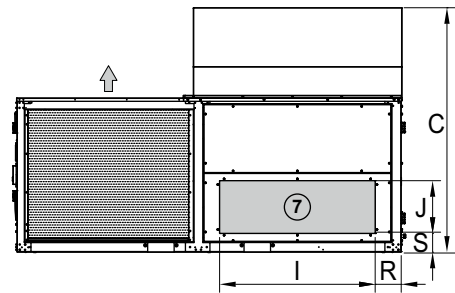
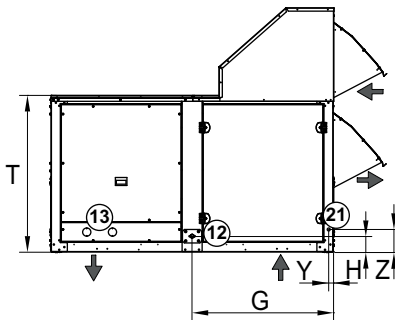
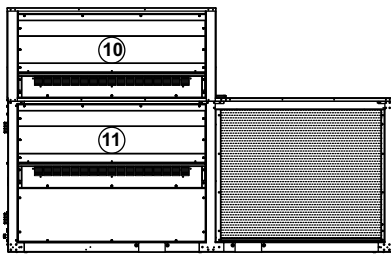
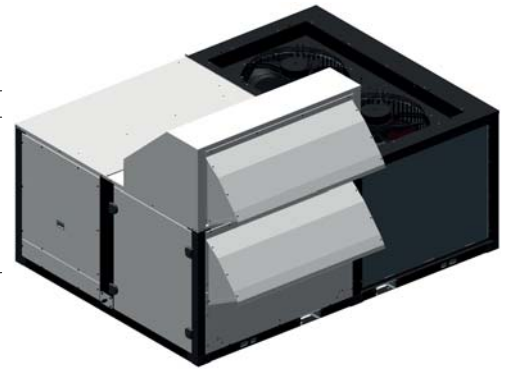
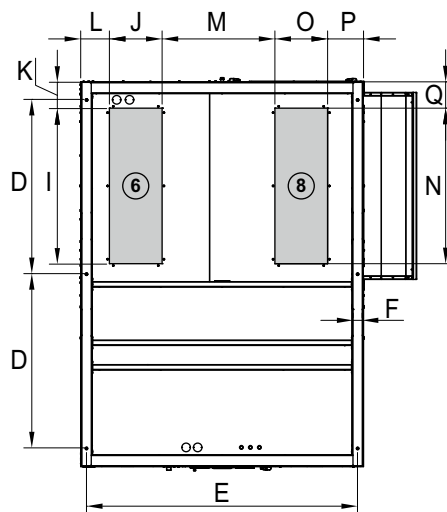

Dimensions	L x W x H			Supply										Return											
	A	B	C	D	E	F	G	H	I	J	K	L	M	N	O	P	Q	R	S	T	V	W	X	Y	Z
<b>0200 to 0240 (mm)</b>	3.000	2.205	1.905	1.356	2.108	72	1.098	125	1.210	410	205	223	877	1.210	410	279	205	203	147	1.230	410	1.455	86	45	174
<b>0280 to 0380 (mm)</b>	3.655	2.205	1.905	1.683	2.108	72	1.098	125	1.510	410	245	223	877	1.510	410	279	245	243	147	1.230	410	1.835	86	45	174

Note: Drawings without scale. Refer to the certified dimensional drawings available on request, when designing an installation.



**DIMENSIONAL DRAWINGS: IPJ SERIES**

**IPJ - 0090 / 0120 / 0140 / 0160 / 0180 / 0190, CQ and CT assemblies**

- ➔ Outdoor air circulation
  - ➔ Standard indoor air circulation
  - ⚠ Electrical cabinet
  - ⚡ Electric power supply
  - 🚪 Door switch
  - ⑥ Lower air supply
  - ⑦ Lateral air supply
  - ⑨ Lateral air return
  - ⑩ Fresh air intake
  - ⑪ Exhaust air outlet
  - ⑫ Condensate outlet 1/2"M
  - ⑬ HWC connections (option)
  - ⑳ Recovery circuit condensate outlet 1/2"M (CT assembly)
- Anti-vibration anchoring: rivet nut M12

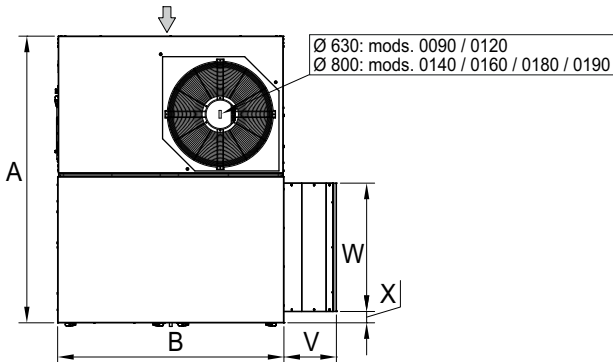
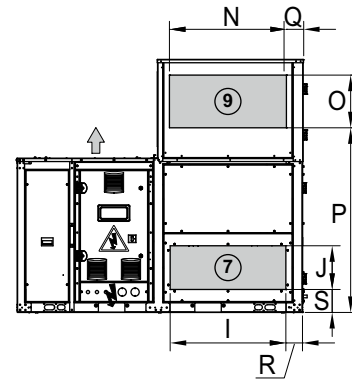
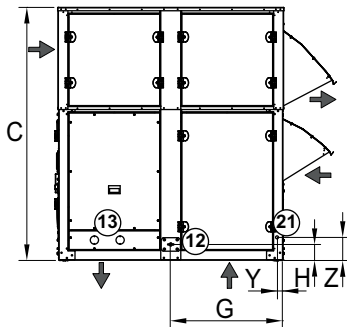
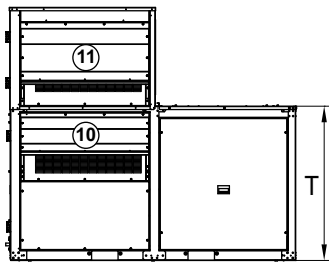
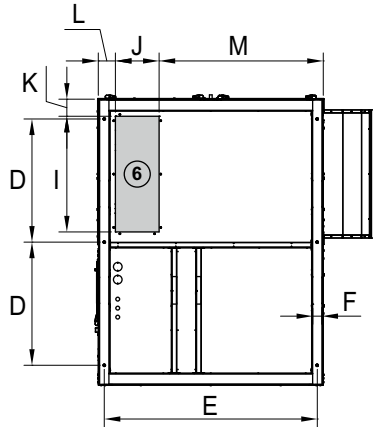

Dimensions	L x W x H			Supply											Return										
	A	B	C	D	E	F	G	H	I	J	K	L	M	N	O	P	Q	R	S	T	V	W	X	Y	Z
0090 to 0190 (mm)	2.230	1.760	1.975	958	1.657	72	872	125	900	340	133	133	1.277	910	410	1.436	133	129	179	1.200	410	998	88	45	174

Note: Drawings without scale. Refer to the certified dimensional drawings available on request, when designing an installation.

**DIMENSIONAL DRAWINGS: IPJ SERIES**

**IPJ - 0200 / 0220 / 0240 / 0280 / 0320 / 0360 / 0380, CQ and CT assemblies**

- ➔ Outdoor air circulation
  - ➔ Standard indoor air circulation
  - ⚠ Electrical cabinet
  - ⚡ Electric power supply
  - ⑤ Door switch
  - ⑥ Lower air supply
  - ⑦ Lateral air supply
  - ⑨ Lateral air return
  - ⑩ Fresh air intake
  - ⑪ Exhaust air outlet
  - ⑫ Condensate outlet 1/2"M
  - ⑬ HWC connections (option)
  - ⑳ Recovery circuit condensate outlet 1/2"M (CT assembly)
- Anti-vibration anchoring: rivet nut M12

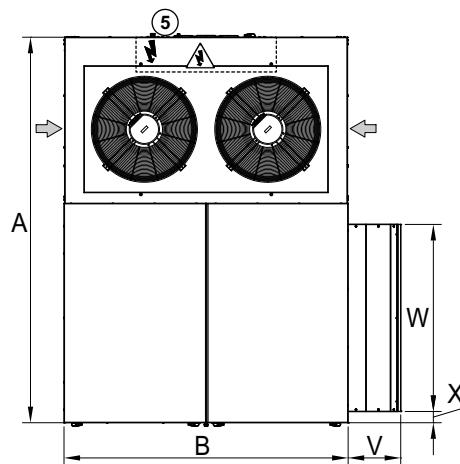
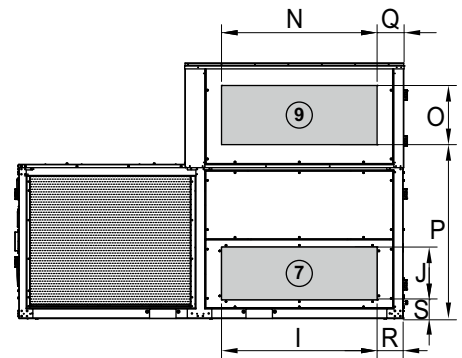
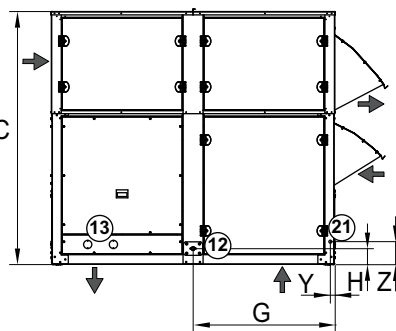
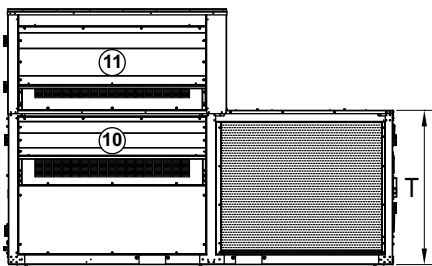
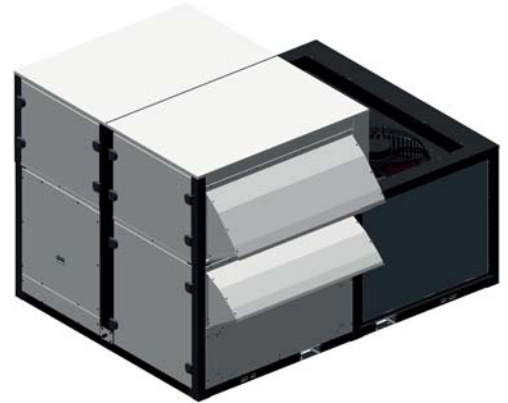
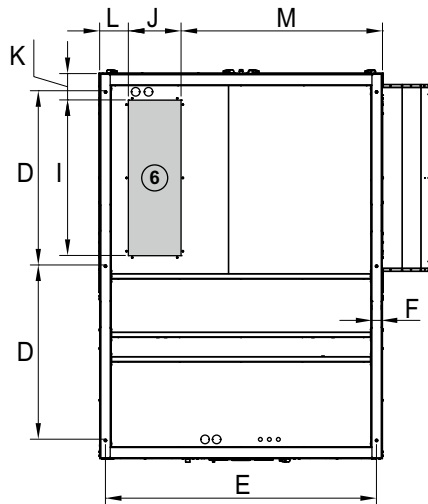

Dimensions	L x W x H			Supply									Return												
	A	B	C	D	E	F	G	H	I	J	K	L	M	N	O	P	Q	R	S	T	V	W	X	Y	Z
<b>0200 to 0240 (mm)</b>	3.000	2.210	1.995	1.356	2.108	72	1.098	125	1.210	410	205	223	1.567	1.210	460	1.353	210	203	147	1.200	410	1.455	88	45	174
<b>0280 to 0380 (mm)</b>	3.655	2.210	1.995	1.683	2.108	72	1.098	125	1.510	410	245	223	1.567	1.210	460	1.353	400	243	147	1.200	410	1.835	88	45	174

Note: Drawings without scale. Refer to the certified dimensional drawings available on request, when designing an installation.

**DIMENSIONAL DRAWINGS: IPJ SERIES**

**IPJ - 0090 / 0120 / 0140 / 0160 / 0180 / 0190, CW assembly**

- ➔ Outdoor air circulation
  - ➔ Standard indoor air circulation
  - ⚠ Electrical cabinet
  - ⚡ Electric power supply
  - 🚪 Door switch
  - ⑥ Lower air supply
  - ⑦ Lateral air supply
  - ⑧ Lower air return
  - ⑩ Fresh air intake
  - ⑪ Exhaust air outlet
  - ⑫ Condensate outlet 1/2"M
  - ⑬ HWC connections (option)
  - ⑭ Wheel condensate outlet 1/2"M
- Anti-vibration anchoring: rivet nut M12

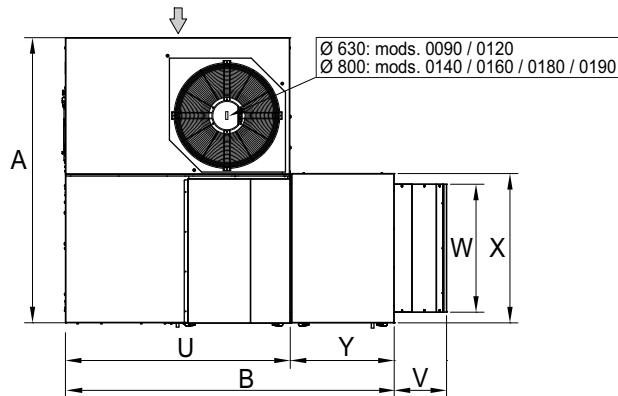
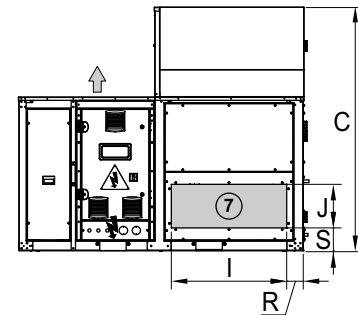
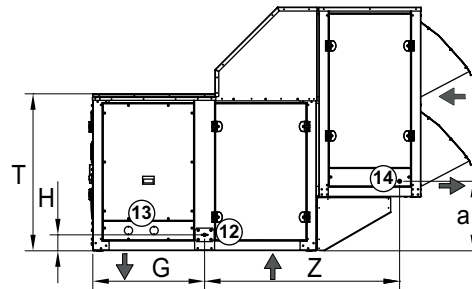
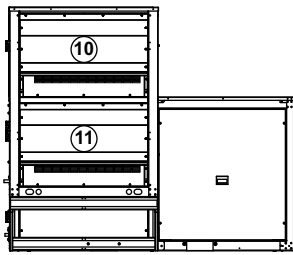
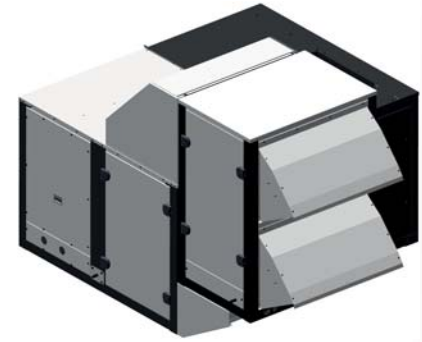
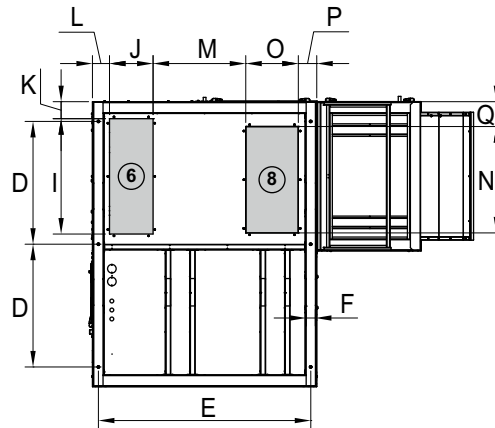

Dimensions	L x W x H			Supply													Return				a						
	A	B	C	D	E	F	G	H	I	J	K	L	M	N	O	P	Q	R	S	T		U	V	W	X	Y	Z
0090 to 0190 (mm)	2.230	2.565	1.905	958	1.657	72	872	125	900	340	133	133	723	830	410	144	194	129	179	1.230	1.755	410	998	1.165	810	1.521	543

Note: Drawings without scale. Refer to the certified dimensional drawings available on request, when designing an installation.

**DIMENSIONAL DRAWINGS: IPJ SERIES**

**IPJ - 0200 / 0220 / 0240 / 0280 / 0320 / 0360 / 0380, CW assembly**

- ↔ Outdoor air circulation
  - ➔ Standard indoor air circulation
  - ⚠ Electrical cabinet
  - ⚡ Electric power supply
  - ⑤ Door switch
  - ⑥ Lower air supply
  - ⑦ Lateral air supply
  - ⑧ Lower air return
  - ⑩ Fresh air intake
  - ⑪ Exhaust air outlet
  - ⑫ Condensate outlet 1/2"M
  - ⑬ HWC connections (option)
  - ⑭ Wheel condensate outlet 1/2"M
- Anti-vibration anchoring: rivet nut M12

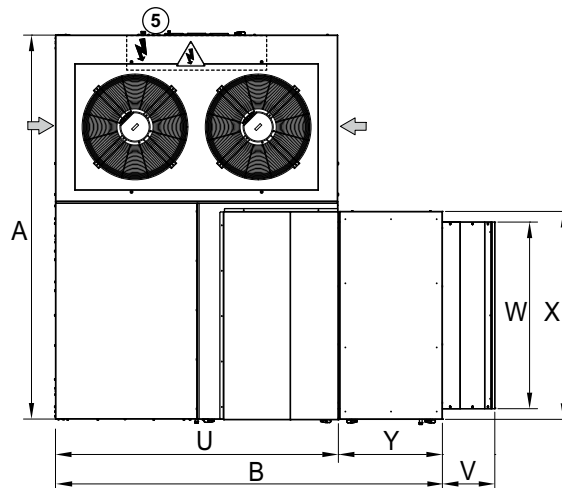
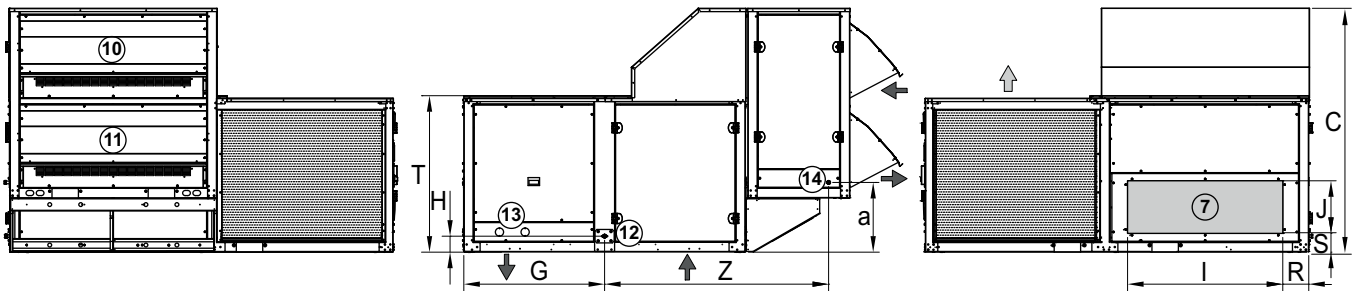
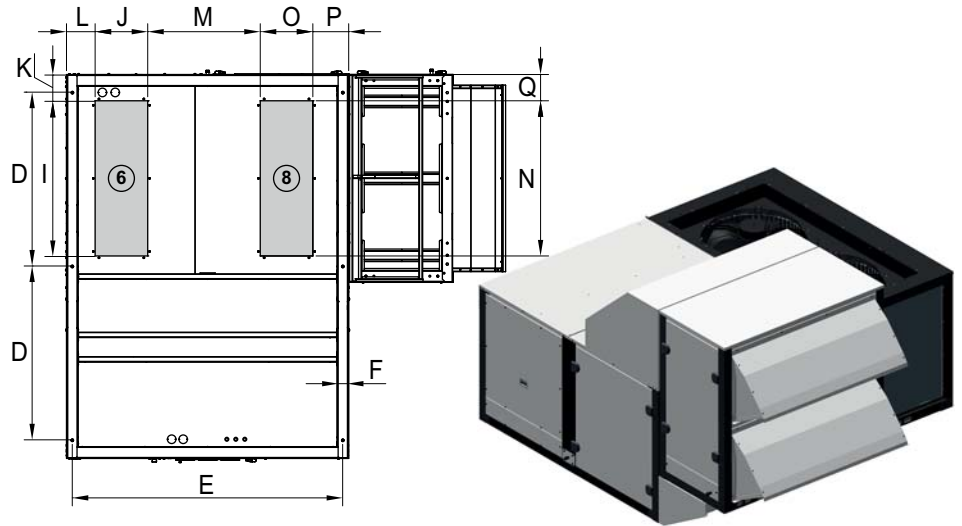

Dimensions	L x W x H			Supply													Return				a						
	A	B	C	D	E	F	G	H	I	J	K	L	M	N	O	P	Q	R	S	T		U	V	W	X	Y	Z
<b>0200 to 0240 (mm)</b>	3.000	3.015	1.905	1.356	2.108	72	1.098	125	1.210	410	205	223	877	1.210	410	279	205	203	147	1.230	2.205	410	1.455	1.621	810	1.746	544
<b>0280 to 0380 (mm)</b>	3.655	3.015	1.905	1.683	2.108	72	1.098	125	1.510	410	245	223	877	1.510	410	279	245	243	147	1.230	2.205	410	1.835	2.201	810	1.746	243

Note: Drawings without scale. Refer to the certified dimensional drawings available on request, when designing an installation.

## DIMENSIONAL DRAWINGS: IPJ SERIES

### IPJ - 0200 / 0220 / 0240 / 0280 / 0320 / 0360 / 0380, T0 assembly

- ➔ Outdoor air circulation
  - ➔ Standard indoor air circulation
  - ⚠ Electrical cabinet
  - ⚡ Electric power supply
  - ⑤ Door switch
  - ⑥ Lower air supply
  - ⑧ Lower air return
  - ⑨ Lateral air return
  - ⑫ Condensate outlet 1/2" M
  - ⑬ HWC connections (option)
- Anti-vibration anchoring: rivet nut M12



Vectios™ PJ

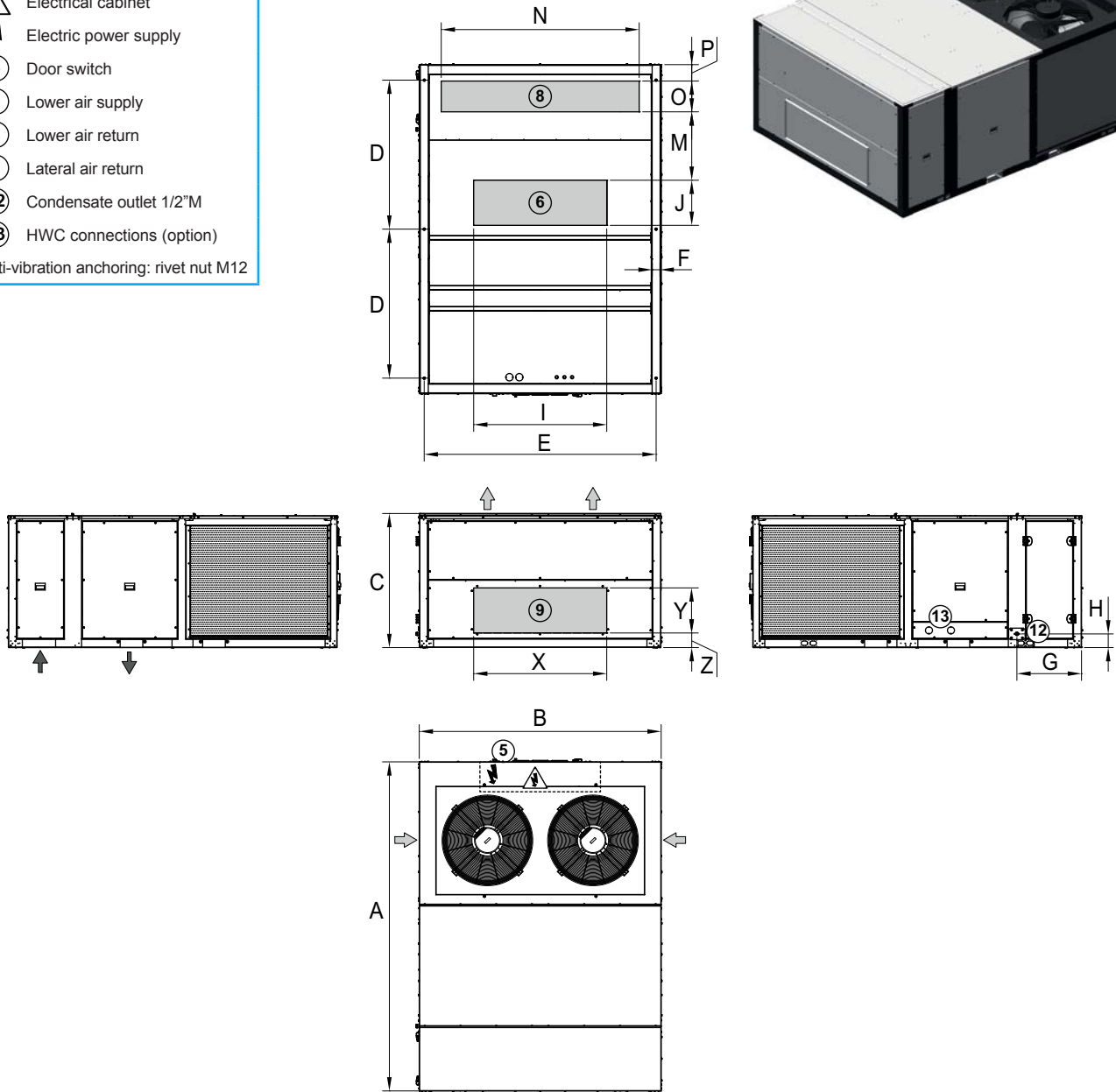

Dimensions	L x W x H								Supply			Return					
	A	B	C	D	E	F	G	H	I	J	M	N	O	P	X	Y	Z
0200 to 0240 (mm)	3.000	2.200	1.230	1.356	2.108	72	587	125	1.210	410	622	1.800	280	150	1.210	410	133
0280 to 0380 (mm)	3.650	2.200	1.230	1.683	2.108	72	967	125	1.510	410	774	1.510	410	248	1.510	410	147

Note: Drawings without scale. Refer to the certified dimensional drawings available on request, when designing an installation.

**DIMENSIONAL DRAWINGS: IPJ SERIES**

**IPJ - 0200 / 0220 / 0240, TS assembly**

- ➔ Outdoor air circulation
  - ➔ Standard indoor air circulation
  - ⚠ Electrical cabinet
  - ⚡ Electric power supply
  - ⑤ Door switch
  - ⑥ Lower air supply
  - ⑧ Lower air return
  - ⑨ Lateral air return
  - ⑩ Fresh air intake
  - ⑫ Condensate outlet 1/2" M
  - ⑬ HWC connections (option)
  - ⑮ Enclosure for lower return (on-site configuration)
- Anti-vibration anchoring: rivet nut M12

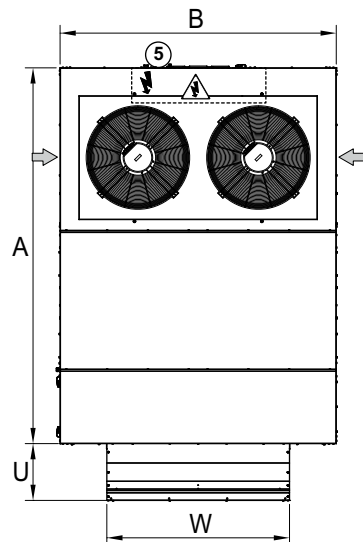
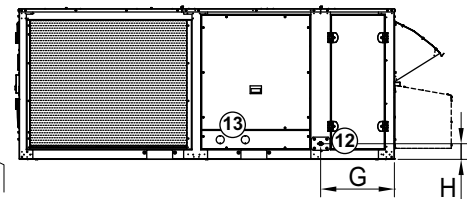
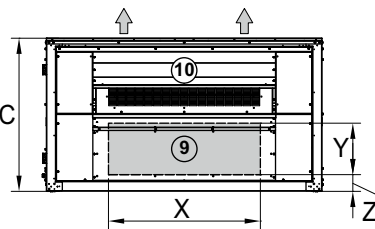
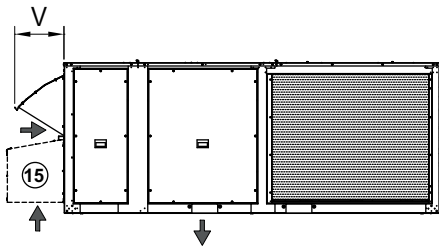
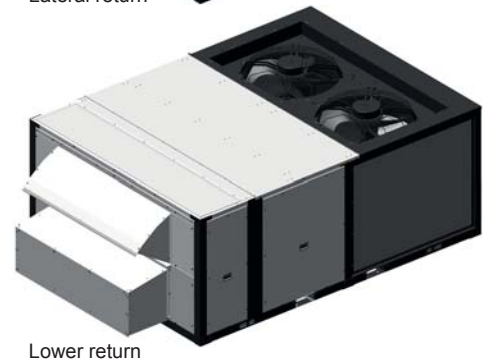
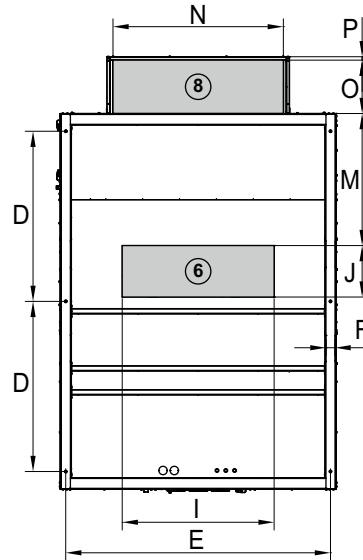

Dimensions	L x W x H										Supply			Return								
	A	B	C	D	E	F	G	H	I	J	M	N	O	P	U	V	W	X	Y	Z		
<b>0200 to 0240 (mm)</b>	3.000	2.200	1.230	1.356	2.108	72	587	125	1.210	410	1.052	1.357	125	27	452	392	1.455	1.210	410	133		

Note: Drawings without scale. Refer to the certified dimensional drawings available on request, when designing an installation.

**DIMENSIONAL DRAWINGS: IPJ SERIES**

**IPJ - 0280 / 0320 / 0360 / 0380, TS assembly**

- ➔ Outdoor air circulation
  - ➔ Indoor air circulation
  - ⚠ Electrical cabinet
  - ⚡ Electric power supply
  - 🚪 Door switch
  - ⑥ Lower air supply
  - ⑧ Lower air return
  - ⑨ Lateral air return
  - ⑩ Fresh air intake
  - ⑫ Condensate outlet 1/2"M
  - ⑬ HWC connections (option)
- Anti-vibration anchoring: rivet nut M12

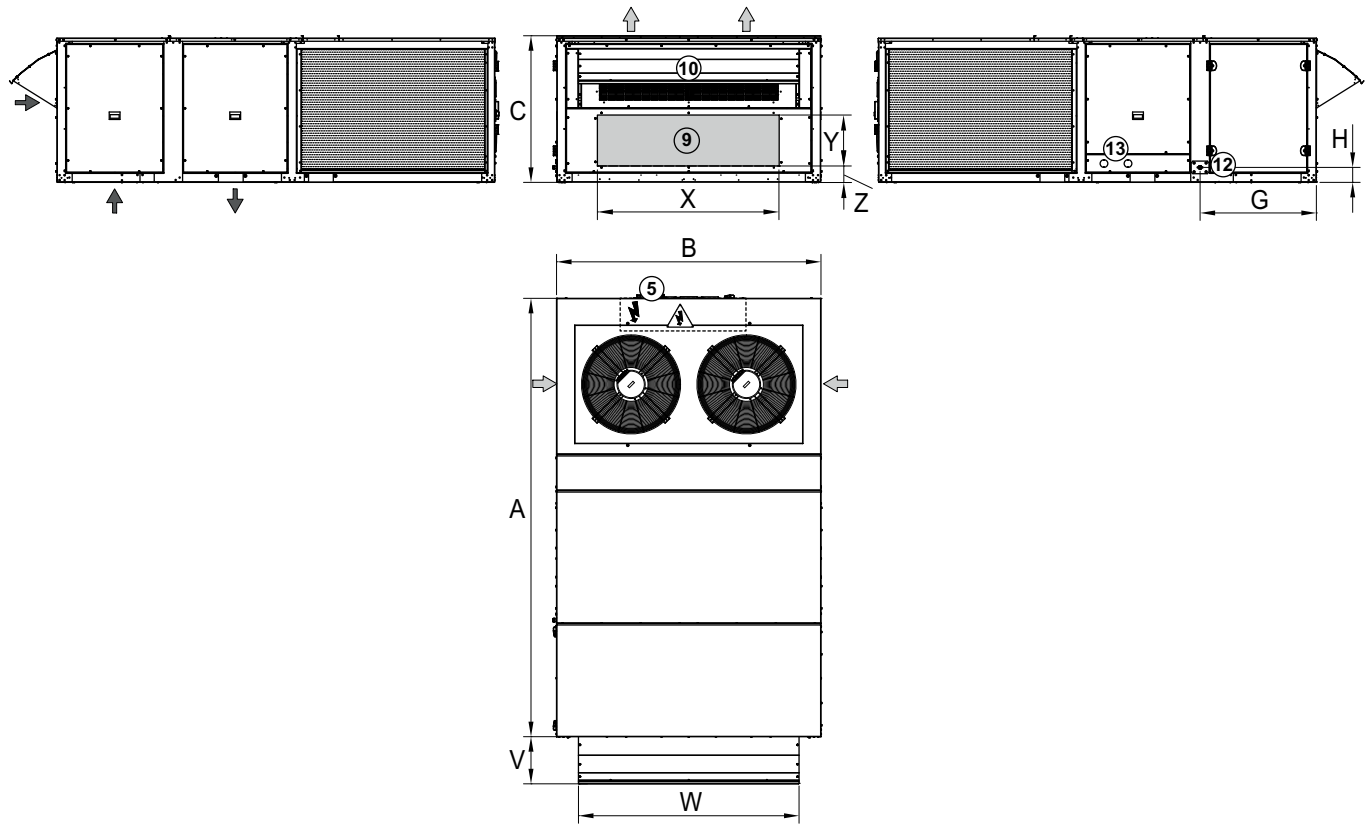
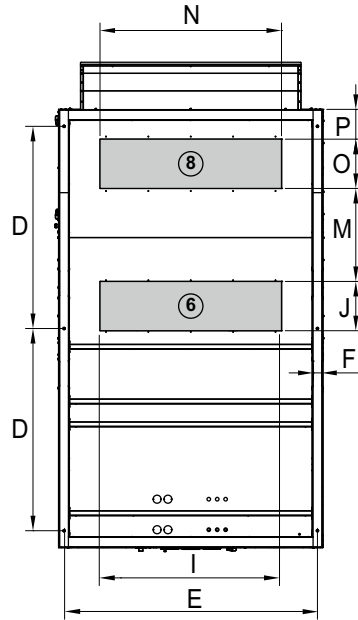

Dimensions	L x W x H			Supply							Return			P	V	W	X	Y	Z
	A	B	C	D	E	F	G	H	I	J	M	N	O						
0280 to 0380 (mm)	3.650	2.200	1.230	1.683	2.108	72	967	125	1.510	410	774	1.510	410	248	392	1.835	1.510	410	147

Note: Drawings without scale. Refer to the certified dimensional drawings available on request, when designing an installation.

**DIMENSIONAL DRAWINGS: IPJ SERIES**

**IPJ - 0200 / 0220 / 0240, TP assembly**

- ➔ Outdoor air circulation
  - ➔ Indoor air circulation
  - ⚠ Electrical cabinet
  - ⚡ Electric power supply
  - ⑤ Door switch
  - ⑥ Lower air supply
  - ⑧ Lower air return
  - ⑩ Fresh air intake
  - ⑪ Exhaust air outlet
  - ⑫ Condensate outlet 1/2" M
  - ⑬ HWC connections (option)
- Anti-vibration anchoring: rivet nut M12

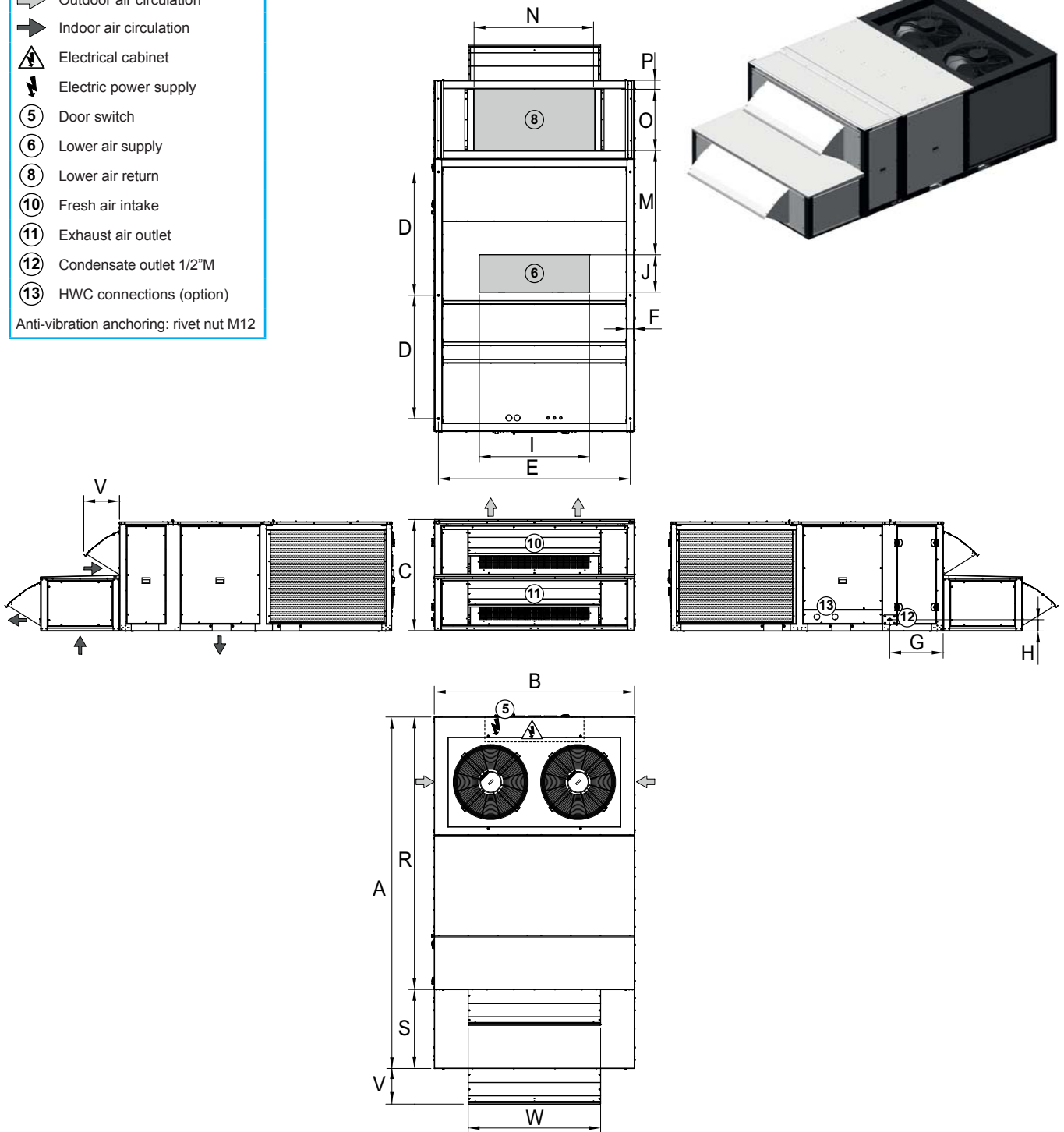

Dimensions	L x W x H								Supply		Return							
	A	B	C	D	E	F	G	H	I	J	M	N	O	P	R	S	V	W
<b>0200 to 0240 (mm)</b>	3.865	2.200	1.230	1.356	2108	72	587	125	1.210	410	1.144	1.330	680	95	2.995	870	297	1.455

Note: Drawings without scale. Refer to the certified dimensional drawings available on request, when designing an installation.



**DIMENSIONAL DRAWINGS: IPJ SERIES**

**IPJ - 0280 / 0320 / 0360 / 0380, TP assembly**

- ➔ Outdoor air circulation
  - ➔ Indoor air circulation
  - ⚠ Electrical cabinet
  - ⚡ Electric power supply
  - ⑤ Door switch
  - ⑥ Lower air supply
  - ⑧ Lower air return
  - ⑩ Fresh air intake
  - ⑪ Exhaust air outlet
  - ⑫ Condensate outlet 1/2"M
  - ⑬ HWC connections (option)
- Anti-vibration anchoring: rivet nut M12

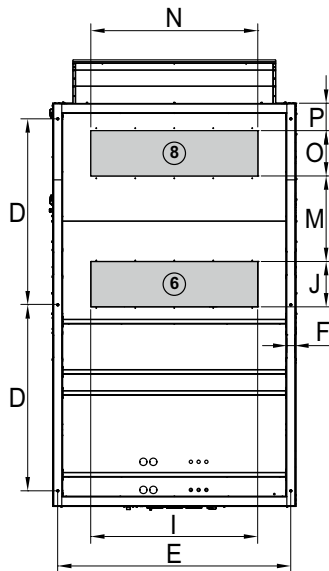

Vectios™ PJ

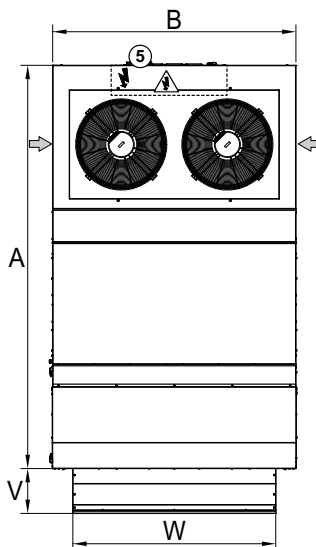
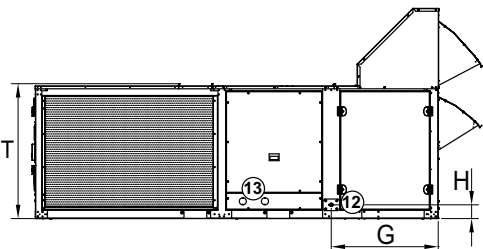
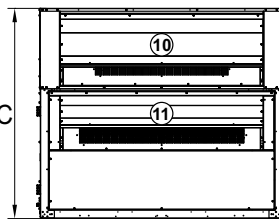
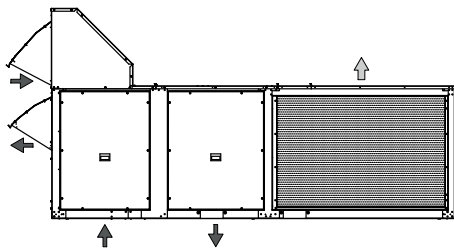

Dimensions	L x W x H			D	E	F	G	H	Supply			Return		P	T	V	W
	A	B	C						I	J	M	N	O				
<b>0280 to 0380 (mm)</b>	3.655	2.210	1.905	1.683	2.108	72	967	125	1.510	410	774	1.510	410	248	1.230	410	1.835

Note: Drawings without scale. Refer to the certified dimensional drawings available on request, when designing an installation.

**DIMENSIONAL DRAWINGS: IPJ SERIES**

**IPJ - 0200 / 0220 / 0240 / 0280 / 0320 / 0360 / 0380, TW assembly**

- ↔ Outdoor air circulation
  - Indoor air circulation
  - ⚠ Electrical cabinet
  - ⚡ Electric power supply
  - ⑤ Door switch
  - ⑥ Lower air supply
  - ⑧ Lower air return
  - ⑩ Fresh air intake
  - ⑪ Exhaust air outlet
  - ⑫ Condensate outlet 1/2" M
  - ⑬ HWC connections (option)
  - ⑭ Wheel condensate outlet 1/2" M
- Anti-vibration anchoring: rivet nut M12

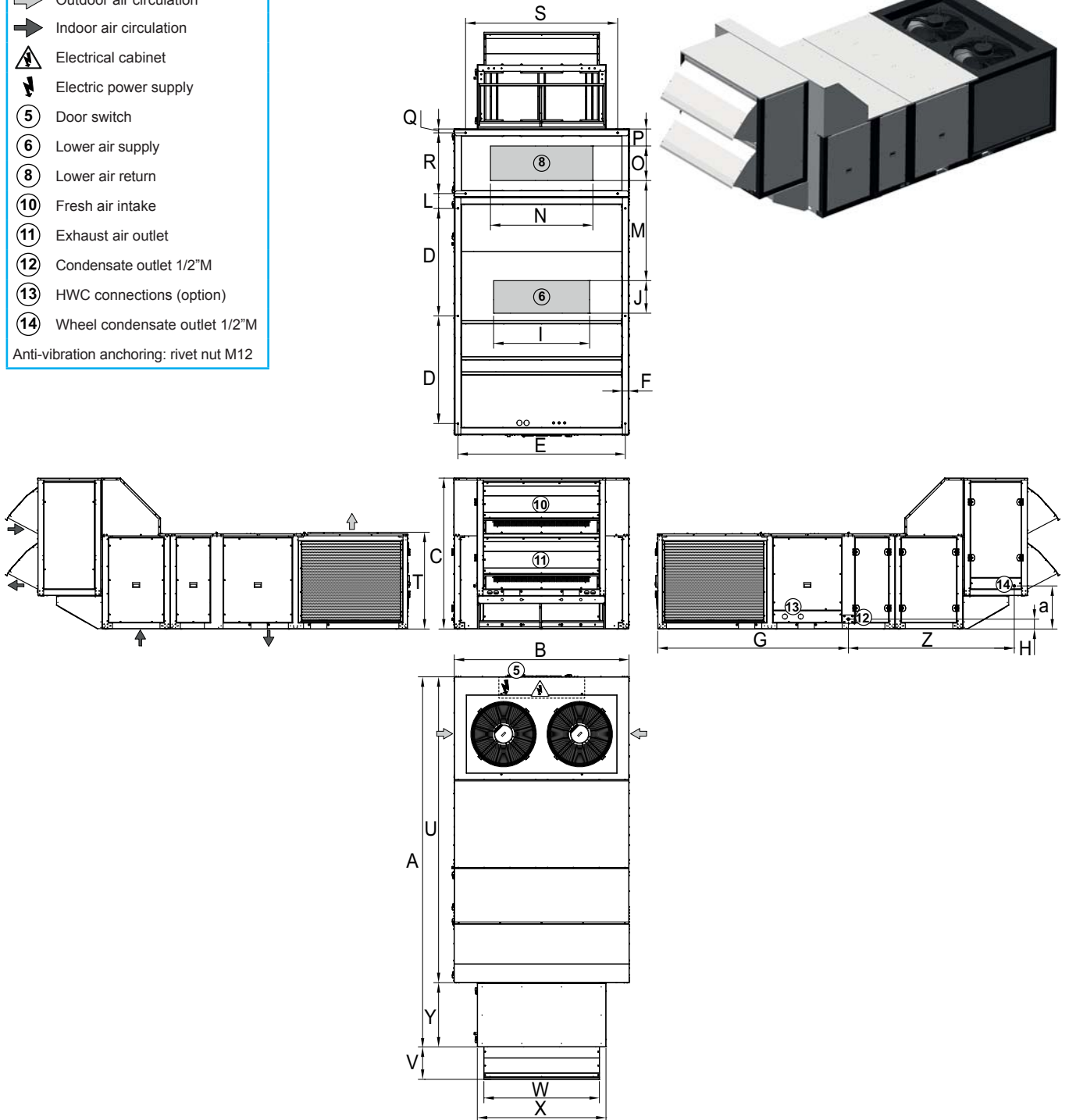
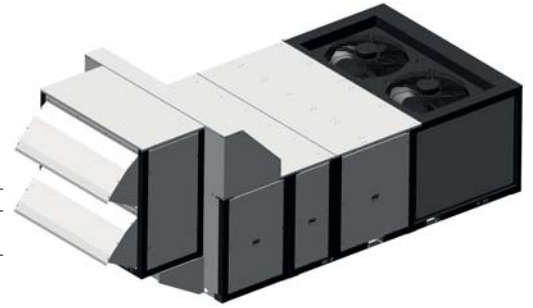

Dimensions	L x W x H											Supply		Return													
	A	B	C	D	E	F	G	H	I	J	L	M	N	O	P	Q	R	S	T	U	V	W	X	Y	Z	a	
<b>0200 to 0240 (mm)</b>	4.675	2.210	1.905	1.356	2.108	72	2.402	125	1.210	410	196	1.271	1.290	435	215	48	766	1.916	1.230	3.865	410	1.455	1.621	810	2.100	544	
<b>0280 to 0380 (mm)</b>	4.465	2.210	1.905	1.683	2.108	72	2.676	125	1.510	410	--	774	1.510	410	248	--	--	--	1.230	3.655	410	1.835	2.001	810	1.614	243	

Note: Drawings without scale. Refer to the certified dimensional drawings available on request, when designing an installation.

## CENTRE OF GRAVITY AND REACTIONS IN THE SUPPORTS: RPJ SERIES

### Cross flow

RPJ	C0 assembly									
	Centre of gravity (mm)			Weight (kg)	Reactions in the supports (kg)					
	X	Y	Z		R1	R2	R3	R4	R5	R6
0090	1.083	779	554	594	93	154	84	70	131	61
0120	1.066	791	567	617	98	158	83	77	137	62
0140	1.048	761	572	699	119	183	95	87	151	63
0160	1.050	762	572	698	118	183	95	86	151	64
0180	1.049	763	579	704	119	185	96	87	153	64
0190	1.049	761	576	701	119	184	96	87	152	64

RPJ	CS assembly									
	Centre of gravity (mm)			Weight (kg)	Reactions in the supports (kg)					
	X	Y	Z		R1	R2	R3	R4	R5	R6
0090	1.104	803	558	609	90	155	87	72	137	69
0120	1.087	814	570	632	94	159	86	79	144	70
0140	1.065	783	571	718	116	185	98	89	159	71
0160	1.065	783	571	718	116	185	98	89	159	71
0180	1.064	784	581	718	116	185	98	89	159	71
0190	1.064	782	575	720	116	186	98	89	159	71

RPJ	CK assembly									
	Centre of gravity (mm)			Weight (kg)	Reactions in the supports (kg)					
	X	Y	Z		R1	R2	R3	R4	R5	R6
0090	1.162	868	629	682	82	165	99	79	162	96
0120	1.145	876	638	705	87	169	98	86	169	97
0140	1.120	841	631	796	108	197	111	97	185	99
0160	1.120	841	631	796	108	197	111	97	185	99
0180	1.119	841	640	796	109	196	110	97	185	99
0190	1.119	840	635	798	109	197	111	97	185	99

RPJ	CA assembly									
	Centre of gravity (mm)			Weight (kg)	Reactions in the supports (kg)					
	X	Y	Z		R1	R2	R3	R4	R5	R6
0090	1.183	890	615	713	79	169	104	82	173	107
0120	1.165	896	624	736	83	174	103	89	179	108
0140	1.134	857	621	815	105	199	114	99	192	107
0160	1.134	857	621	815	105	199	114	99	192	107
0180	1.133	857	630	815	105	198	113	99	192	107
0190	1.133	856	625	817	106	199	114	99	192	107

RPJ	CP assembly									
	Centre of gravity (mm)			Weight (kg)	Reactions in the supports (kg)					
	X	Y	Z		R1	R2	R3	R4	R5	R6
0090	1.187	897	617	723	78	170	105	83	176	110
0120	1.170	903	626	746	83	175	104	90	182	112
0140	1.144	863	621	831	104	202	117	100	197	112
0160	1.144	863	621	831	104	202	117	100	197	112
0180	1.138	862	631	828	105	201	115	100	196	110
0190	1.143	862	625	833	105	202	117	100	197	112

RPJ	CR assembly									
	Centre of gravity (mm)			Weight (kg)	Reactions in the supports (kg)					
	X	Y	Z		R1	R2	R3	R4	R5	R6
0090	1.163	934	613	781	83	178	103	101	196	120
0120	1.148	939	620	804	88	183	102	108	203	121
0140	1.102	926	614	900	112	207	106	129	224	123
0160	1.102	926	614	900	112	207	106	129	224	123
0180	1.101	927	622	897	111	206	105	129	223	122
0190	1.101	925	618	902	112	208	106	129	224	123

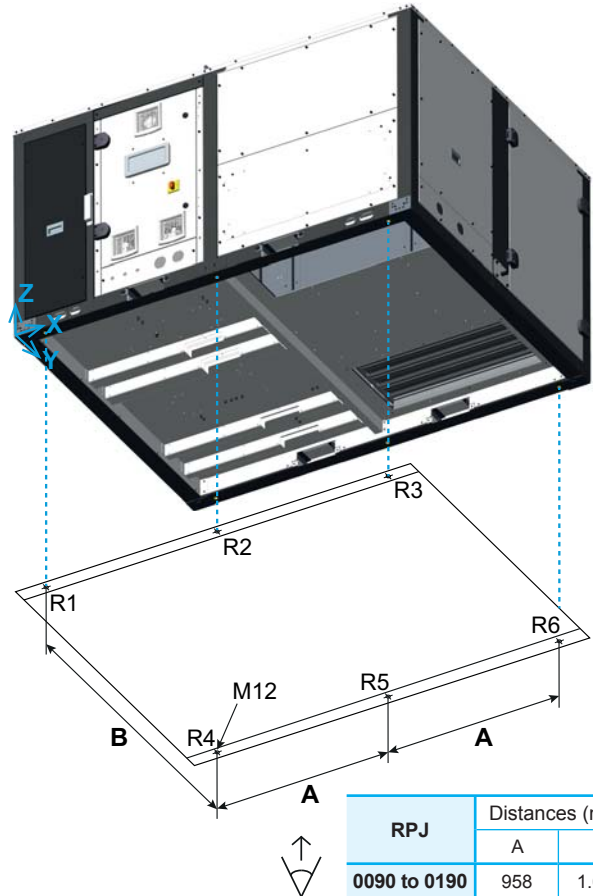

RPJ	CQ assembly									
	Centre of gravity (mm)			Weight (kg)	Reactions in the supports (kg)					
	X	Y	Z		R1	R2	R3	R4	R5	R6
0090	1.222	804	796	774	91	197	134	67	174	111
0120	1.205	813	800	797	96	202	133	74	180	112
0140	1.177	787	779	882	117	228	145	84	195	113
0160	1.177	787	779	882	117	228	145	84	195	113
0180	1.176	788	787	882	117	228	145	84	195	113
0190	1.176	787	782	884	118	228	146	85	195	113

RPJ	CT assembly									
	Centre of gravity (mm)			Weight (kg)	Reactions in the supports (kg)					
	X	Y	Z		R1	R2	R3	R4	R5	R6
0090	1.200	850	780	832	98	206	132	84	193	119
0120	1.184	857	782	855	103	211	131	91	199	120
0140	1.138	849	764	951	124	234	135	112	222	123
0160	1.138	849	764	951	124	234	135	112	222	123
0180	1.138	850	772	951	124	234	135	113	222	123
0190	1.137	848	767	953	125	234	135	113	222	123

RPJ	CW assembly									
	Centre of gravity (mm)			Weight (kg)	Reactions in the supports (kg)					
	X	Y	Z		R1	R2	R3	R4	R5	R6
0090	1.301	1.243	719	976	87	242	182	72	226	167
0120	1.286	1.240	724	999	94	248	183	77	231	166
0140	1.258	1.188	713	1.088	130	249	211	89	240	170
0160	1.258	1.188	713	1.088	130	249	211	89	240	170
0180	1.257	1.189	719	1.088	130	249	211	89	240	170
0190	1.257	1.187	715	1.091	131	250	211	89	240	170

**CENTRE OF GRAVITY AND REACTIONS IN THE SUPPORTS: RPJ SERIES**

**Cross flow**

RPJ	C0 assembly									
	Centre of gravity (mm)			Weight (kg)	Reactions in the supports (kg)					
	X	Y	Z		R1	R2	R3	R4	R5	R6
0200	1.377	1.046	564	914	147	227	106	132	211	91
0220	1.377	1.046	564	929	150	230	108	134	215	92
0240	1.369	1.040	563	936	154	233	108	136	215	90

RPJ	CS assembly									
	Centre of gravity (mm)			Weight (kg)	Reactions in the supports (kg)					
	X	Y	Z		R1	R2	R3	R4	R5	R6
0200	1.396	1.067	562	946	146	232	110	136	222	100
0220	1.393	1.070	561	967	150	236	111	140	227	102
0240	1.387	1.066	561	969	152	237	111	141	227	101

RPJ	CK assembly									
	Centre of gravity (mm)			Weight (kg)	Reactions in the supports (kg)					
	X	Y	Z		R1	R2	R3	R4	R5	R6
0200	1.476	1.138	622	1.047	135	245	126	147	257	138
0220	1.476	1.138	622	1.062	137	248	128	149	260	140
0240	1.467	1.131	620	1.070	141	252	128	151	261	138

RPJ	CA assembly									
	Centre of gravity (mm)			Weight (kg)	Reactions in the supports (kg)					
	X	Y	Z		R1	R2	R3	R4	R5	R6
0200	1.494	1.153	608	1.090	135	253	132	152	270	149
0220	1.491	1.155	607	1.111	137	257	133	156	275	152
0240	1.485	1.151	606	1.112	140	258	133	156	275	150

RPJ	CP assembly									
	Centre of gravity (mm)			Weight (kg)	Reactions in the supports (kg)					
	X	Y	Z		R1	R2	R3	R4	R5	R6
0200	1.512	1.167	609	1.120	132	257	137	155	280	160
0220	1.509	1.170	608	1.141	135	261	138	159	285	163
0240	1.503	1.165	607	1.142	137	262	138	159	285	161

RPJ	CR assembly									
	Centre of gravity (mm)			Weight (kg)	Reactions in the supports (kg)					
	X	Y	Z		R1	R2	R3	R4	R5	R6
0200	1.487	1.204	607	1.211	141	271	135	180	310	174
0220	1.484	1.206	606	1.232	144	275	137	184	315	177
0240	1.479	1.201	605	1.233	146	276	137	185	315	175

RPJ	CQ assembly									
	Centre of gravity (mm)			Weight (kg)	Reactions in the supports (kg)					
	X	Y	Z		R1	R2	R3	R4	R5	R6
0200	1.565	1.047	796	1.213	154	302	184	132	280	162
0220	1.565	1.047	796	1.228	156	305	186	134	283	163
0240	1.556	1.042	792	1.236	161	309	186	136	284	161

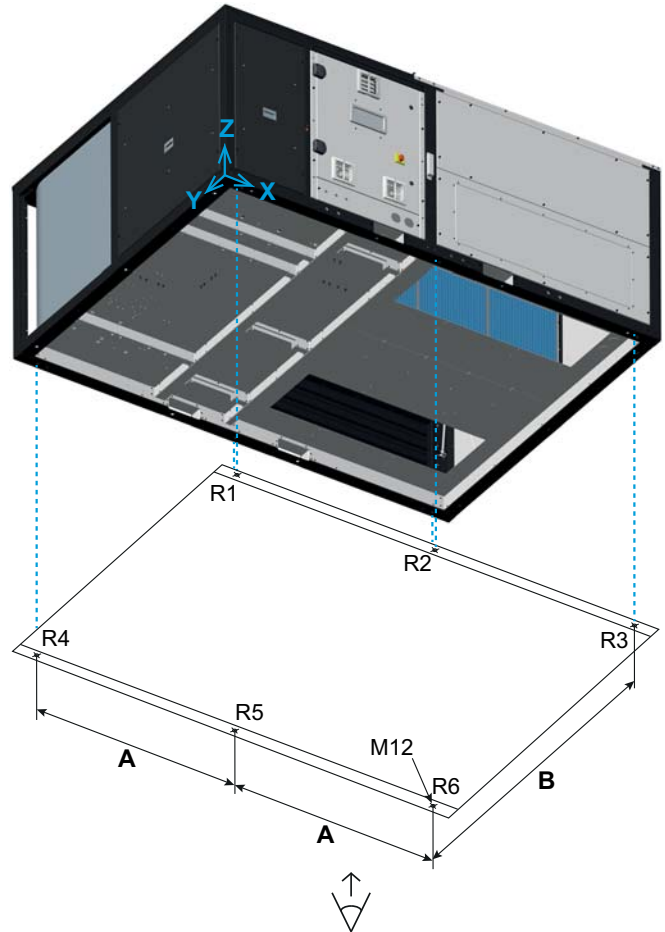

RPJ	Distances (mm)	
	A	B
0200 to 0240	1.356	2.108

RPJ	CT assembly									
	Centre of gravity (mm)			Weight (kg)	Reactions in the supports (kg)					
	X	Y	Z		R1	R2	R3	R4	R5	R6
0200	1.523	1.068	789	1.304	172	320	183	157	305	168
0220	1.520	1.070	787	1.319	174	323	184	160	309	169
0240	1.514	1.067	785	1.327	177	326	184	162	310	168

RPJ	CW assembly									
	Centre of gravity (mm)			Weight (kg)	Reactions in the supports (kg)					
	X	Y	Z		R1	R2	R3	R4	R5	R6
0200	1.661	1.515	696	1.470	146	350	233	150	354	237
0220	1.658	1.516	695	1.491	149	355	236	153	359	239
0240	1.652	1.509	694	1.493	152	357	236	153	358	237

## CENTRE OF GRAVITY AND REACTIONS IN THE SUPPORTS: RPJ SERIES

### Cross flow

RPJ	C0 assembly									
	Centre of gravity (mm)			Weight (kg)	Reactions in the supports (kg)					
	X	Y	Z		R1	R2	R3	R4	R5	R6
0280	1.628	1.054	564	1.035	173	256	112	158	241	97
0320	1.628	1.054	564	1.059	176	261	115	161	246	99
0360	1.644	1.055	572	1.057	174	261	117	158	246	102
0380	1.634	1.048	569	1.078	180	267	119	162	249	101

RPJ	CS assembly									
	Centre of gravity (mm)			Weight (kg)	Reactions in the supports (kg)					
	X	Y	Z		R1	R2	R3	R4	R5	R6
0280	1.659	1.080	563	1.070	169	260	116	162	253	110
0320	1.659	1.080	563	1.094	173	265	119	166	259	112
0360	1.667	1.074	569	1.112	176	271	123	166	262	114
0380	1.664	1.074	568	1.113	176	271	123	167	262	114

RPJ	CK assembly									
	Centre of gravity (mm)			Weight (kg)	Reactions in the supports (kg)					
	X	Y	Z		R1	R2	R3	R4	R5	R6
0280	1.749	1.139	624	1.197	163	280	135	177	294	149
0320	1.749	1.139	624	1.221	166	285	138	180	299	152
0360	1.750	1.139	629	1.230	167	288	139	182	302	153
0380	1.747	1.139	629	1.231	168	288	139	182	302	153

RPJ	CA assembly									
	Centre of gravity (mm)			Weight (kg)	Reactions in the supports (kg)					
	X	Y	Z		R1	R2	R3	R4	R5	R6
0280	1.784	1.168	608	1.248	158	286	142	184	312	167
0320	1.784	1.168	608	1.272	161	292	144	187	318	171
0360	1.790	1.162	613	1.290	163	297	149	187	321	173
0380	1.787	1.161	612	1.291	164	297	148	188	321	172

RPJ	CP assembly									
	Centre of gravity (mm)			Weight (kg)	Reactions in the supports (kg)					
	X	Y	Z		R1	R2	R3	R4	R5	R6
0280	1.798	1.171	611	1.276	158	292	147	186	320	174
0320	1.798	1.171	611	1.300	161	297	149	189	326	178
0360	1.798	1.172	616	1.309	162	299	150	191	328	179
0380	1.795	1.171	615	1.310	163	300	150	191	328	179

RPJ	CR assembly									
	Centre of gravity (mm)			Weight (kg)	Reactions in the supports (kg)					
	X	Y	Z		R1	R2	R3	R4	R5	R6
0280	1.781	1.208	611	1.379	167	308	148	211	353	193
0320	1.781	1.208	611	1.403	169	313	150	215	359	196
0360	1.786	1.202	615	1.412	171	317	154	214	360	197
0380	1.784	1.201	615	1.413	171	317	153	215	360	197

RPJ	CQ assembly									
	Centre of gravity (mm)			Weight (kg)	Reactions in the supports (kg)					
	X	Y	Z		R1	R2	R3	R4	R5	R6
0280	1.852	1.058	787	1.371	184	339	194	163	318	173
0320	1.852	1.058	787	1.395	187	345	197	166	324	176
0360	1.857	1.053	791	1.413	189	350	202	166	327	179
0380	1.855	1.053	789	1.414	190	350	201	167	327	178

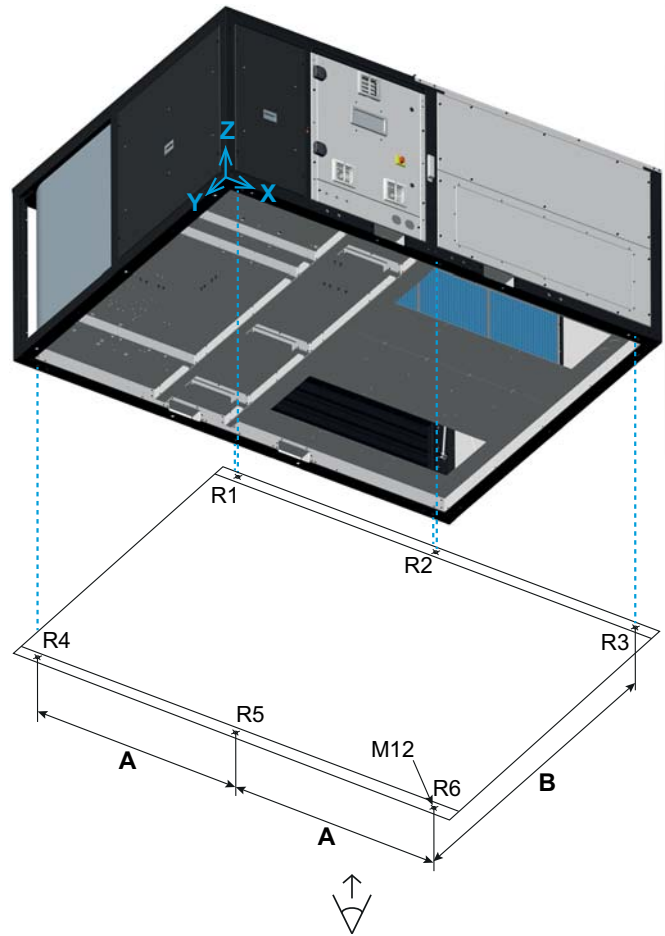

RPJ	Distances (mm)	
	A	B
0280 to 0380	1.683	2.108

RPJ	CT assembly									
	Centre of gravity (mm)			Weight (kg)	Reactions in the supports (kg)					
	X	Y	Z		R1	R2	R3	R4	R5	R6
0280	1.831	1.090	771	1.474	195	357	196	188	350	189
0320	1.831	1.090	771	1.498	198	362	199	191	355	192
0360	1.836	1.085	775	1.516	200	368	204	191	359	195
0380	1.833	1.085	774	1.517	201	368	204	191	359	194

RPJ	CW assembly									
	Centre of gravity (mm)			Weight (kg)	Reactions in the supports (kg)					
	X	Y	Z		R1	R2	R3	R4	R5	R6
0280	1.976	1.513	692	1.660	178	396	251	181	399	254
0320	1.976	1.513	692	1.684	181	402	255	183	405	258
0360	1.979	1.506	695	1.702	184	408	260	183	408	260
0380	1.977	1.505	694	1.703	185	409	260	183	407	259

**CENTRE OF GRAVITY AND REACTIONS IN THE SUPPORTS: RPJ SERIES**

**Tunnel flow**

RPJ	T0 assembly									
	Centre of gravity (mm)			Weight (kg)	Reactions in the supports (kg)					
	X	Y	Z		R1	R2	R3	R4	R5	R6
0200	1.402	1.104	569	972	144	232	108	145	234	110
0220	1.399	1.107	568	993	147	237	110	149	239	112
0240	1.393	1.103	568	994	149	238	109	150	239	110
0280	1.607	1.106	571	1.068	173	255	104	175	257	105
0320	1.607	1.106	571	1.092	177	261	106	179	263	108
0360	1.608	1.106	578	1.111	179	265	108	182	267	110
0380	1.606	1.106	577	1.111	180	265	107	182	267	110

RPJ	TS assembly									
	Centre of gravity (mm)			Weight (kg)	Reactions in the supports (kg)					
	X	Y	Z		R1	R2	R3	R4	R5	R6
0200	1.461	1.103	570	1.010	138	242	124	139	243	125
0220	1.458	1.106	569	1.031	141	246	125	143	248	127
0240	1.452	1.102	569	1.033	144	247	125	144	248	126
0280	1.658	1.104	571	1.105	171	264	116	172	266	117
0320	1.658	1.104	571	1.129	174	270	118	176	271	120
0360	1.659	1.105	577	1.147	177	274	120	178	276	122
0380	1.657	1.105	576	1.148	177	274	120	179	276	122

RPJ	TP assembly									
	Centre of gravity (mm)			Weight (kg)	Reactions in the supports (kg)					
	X	Y	Z		R1	R2	R3	R4	R5	R6
0200	1.732	1.103	535	1.180	197	282	110	198	283	111
0220	1.728	1.105	534	1.201	201	287	110	203	289	112
0240	1.720	1.101	535	1.202	203	288	109	204	288	110
0280	1.866	1.103	615	1.294	161	310	176	161	310	176
0320	1.866	1.103	615	1.318	164	316	180	164	315	179
0360	1.866	1.104	620	1.336	167	320	182	166	320	181
0380	1.863	1.103	619	1.337	167	321	181	167	320	181

RPJ	TW assembly (machine + recovery module)									
	Centre of gravity: machine (mm)			Centre of gravity: module (mm)			Machine weight (kg)	Module weight (kg)		
	X	Y	Z	X	Y	Z				
0200	1.345	1.105	568	905	1.093	864	957	719		
0220	1.342	1.108	567	905	1.093	864	978	719		
0240	1.337	1.103	567	905	1.093	864	980	719		
0280	2.364	1.102	693	--	--	--	1.247	454		
0320	2.364	1.102	693	--	--	--	1.271	454		
0360	2.362	1.103	697	--	--	--	1.289	454		
0380	2.358	1.102	696	--	--	--	1.290	454		

RPJ	TW assembly (machine + recovery module)										
	Total weight (kg)	Reactions in the supports (kg)									
		R1	R2	R3	R4	R5	R6	R7	R8	R9	R10
0200	1.676	132	230	118	131	229	117	150	214	209	146
0220	1.697	135	234	120	135	234	120	150	214	209	146
0240	1.699	137	235	119	136	234	118	150	214	209	146
0280	1.701	189	408	256	187	407	254	--	--	--	--
0320	1.725	192	414	259	190	412	258	--	--	--	--
0360	1.743	194	418	261	193	417	260	--	--	--	--
0380	1.744	195	419	260	194	417	259	--	--	--	--

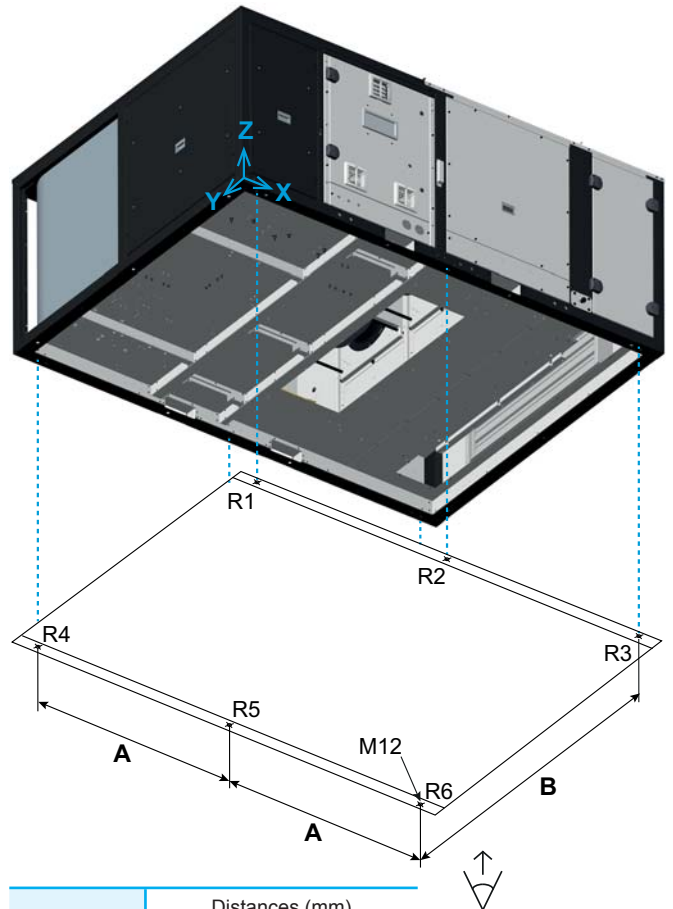

RPJ	Distances (mm)			
	A	B	C	D
0200 to 0240	1.356	2.108	766	1.916
0280 to 0380	1.683	2.108	--	--

**RPJ - 0200 to 0240: TW assembly**  
Recovery module connected to the machine

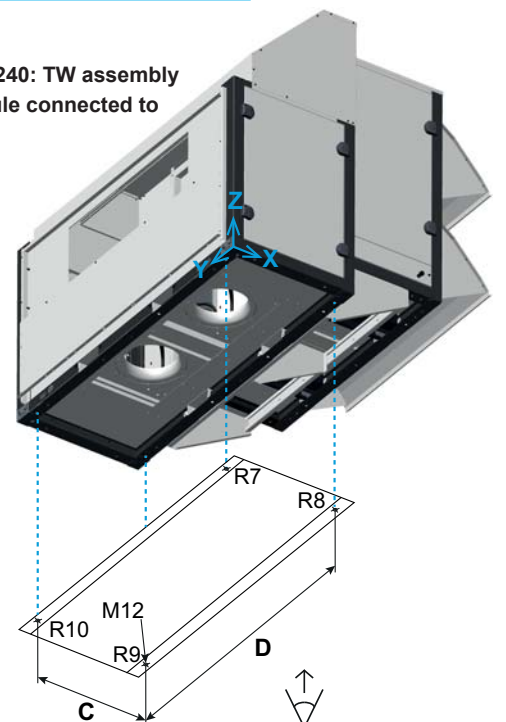

## CENTRE OF GRAVITY AND REACTIONS IN THE SUPPORTS: IPJ SERIES

### Cross flow

IPJ	C0 assembly									
	Centre of gravity (mm)			Weight (kg)	Reactions in the supports (kg)					
	X	Y	Z		R1	R2	R3	R4	R5	R6
0090	1.083	779	554	594	93	154	84	70	131	61
0120	1.066	791	567	617	98	158	83	77	137	62
0140	1.048	761	572	699	119	183	95	87	151	63
0160	1.050	762	572	698	118	183	95	86	151	64
0180	1.049	763	579	704	119	185	96	87	153	64
0190	1.049	761	576	701	119	184	96	87	152	64

IPJ	CS assembly									
	Centre of gravity (mm)			Weight (kg)	Reactions in the supports (kg)					
	X	Y	Z		R1	R2	R3	R4	R5	R6
0090	1.104	803	558	609	90	155	87	72	137	69
0120	1.087	814	570	632	94	159	86	79	144	70
0140	1.065	783	571	718	116	185	98	89	159	71
0160	1.065	783	571	718	116	185	98	89	159	71
0180	1.064	784	581	718	116	185	98	89	159	71
0190	1.064	782	575	720	116	186	98	89	159	71

IPJ	CK assembly									
	Centre of gravity (mm)			Weight (kg)	Reactions in the supports (kg)					
	X	Y	Z		R1	R2	R3	R4	R5	R6
0090	1.162	868	629	682	82	165	99	79	162	96
0120	1.145	876	638	705	87	169	98	86	169	97
0140	1.120	841	631	796	108	197	111	97	185	99
0160	1.120	841	631	796	108	197	111	97	185	99
0180	1.119	841	640	796	109	196	110	97	185	99
0190	1.119	840	635	798	109	197	111	97	185	99

IPJ	CA assembly									
	Centre of gravity (mm)			Weight (kg)	Reactions in the supports (kg)					
	X	Y	Z		R1	R2	R3	R4	R5	R6
0090	1.183	890	615	713	79	169	104	82	173	107
0120	1.165	896	624	736	83	174	103	89	179	108
0140	1.134	857	621	815	105	199	114	99	192	107
0160	1.134	857	621	815	105	199	114	99	192	107
0180	1.133	857	630	815	105	198	113	99	192	107
0190	1.133	856	625	817	106	199	114	99	192	107

IPJ	CP assembly									
	Centre of gravity (mm)			Weight (kg)	Reactions in the supports (kg)					
	X	Y	Z		R1	R2	R3	R4	R5	R6
0090	1.187	897	617	723	78	170	105	83	176	110
0120	1.170	903	626	746	83	175	104	90	182	112
0140	1.144	863	621	831	104	202	117	100	197	112
0160	1.144	863	621	831	104	202	117	100	197	112
0180	1.138	862	631	828	105	201	115	100	196	110
0190	1.143	862	625	833	105	202	117	100	197	112

IPJ	CR assembly									
	Centre of gravity (mm)			Weight (kg)	Reactions in the supports (kg)					
	X	Y	Z		R1	R2	R3	R4	R5	R6
0090	1163	934	613	781	83	178	103	101	196	120
0120	1148	939	620	804	88	183	102	108	203	121
0140	1102	926	614	900	112	207	106	129	224	123
0160	1102	926	614	900	112	207	106	129	224	123
0180	1101	927	622	897	111	206	105	129	223	122
0190	1101	925	618	902	112	208	106	129	224	123

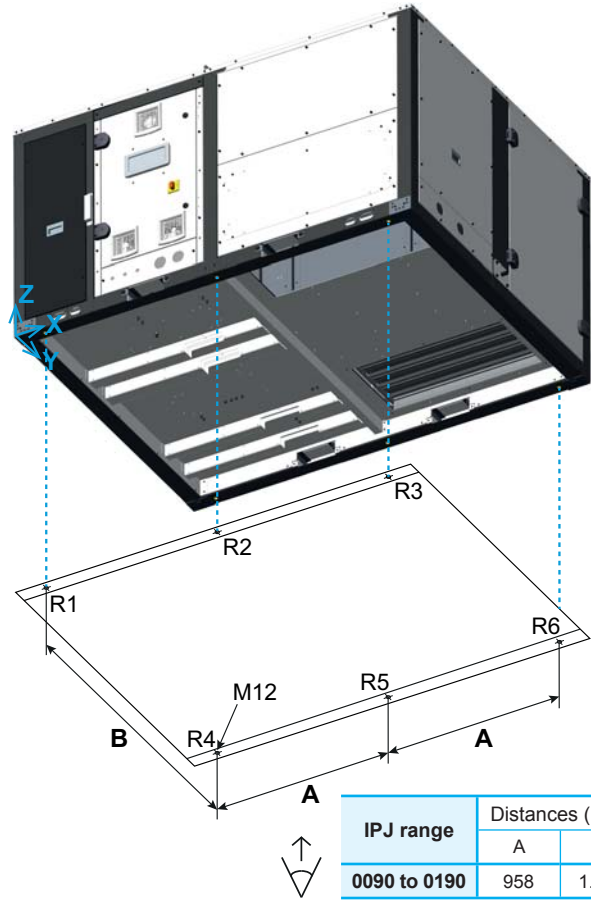

IPJ	CQ assembly									
	Centre of gravity (mm)			Weight (kg)	Reactions in the supports (kg)					
	X	Y	Z		R1	R2	R3	R4	R5	R6
0090	1.222	804	796	774	91	197	134	67	174	111
0120	1.205	813	800	797	96	202	133	74	180	112
0140	1.177	787	779	882	117	228	145	84	195	113
0160	1.177	787	779	882	117	228	145	84	195	113
0180	1.176	788	787	882	117	228	145	84	195	113
0190	1.176	787	782	884	118	228	146	85	195	113

IPJ	CT assembly									
	Centre of gravity (mm)			Weight (kg)	Reactions in the supports (kg)					
	X	Y	Z		R1	R2	R3	R4	R5	R6
0090	1200	850	780	832	98	206	132	84	193	119
0120	1184	857	782	855	103	211	131	91	199	120
0140	1138	849	764	951	124	234	135	112	222	123
0160	1138	849	764	951	124	234	135	112	222	123
0180	1138	850	772	951	124	234	135	113	222	123
0190	1137	848	767	953	125	234	135	113	222	123

IPJ	CW assembly									
	Centre of gravity (mm)			Weight (kg)	Reactions in the supports (kg)					
	X	Y	Z		R1	R2	R3	R4	R5	R6
0090	1.301	1.243	719	976	87	242	182	72	226	167
0120	1.286	1.240	724	999	94	248	183	77	231	166
0140	1.258	1.188	713	1.088	130	249	211	89	240	170
0160	1.258	1.188	713	1.088	130	249	211	89	240	170
0180	1.257	1.189	719	1.088	130	249	211	89	240	170
0190	1.257	1.187	715	1.091	131	250	211	89	240	170

**CENTRE OF GRAVITY AND REACTIONS IN THE SUPPORTS: IPJ SERIES**

**Cross flow**

IPJ	C0 assembly									
	Centre of gravity (mm)			Weight (kg)	Reactions in the supports (kg)					
	X	Y	Z		R1	R2	R3	R4	R5	R6
0200	1.377	1.046	564	986	159	245	114	142	228	98
0220	1.377	1.046	564	986	159	244	114	142	228	98
0240	1.369	1.040	563	1.004	165	250	116	146	231	97

IPJ	CS assembly									
	Centre of gravity (mm)			Weight (kg)	Reactions in the supports (kg)					
	X	Y	Z		R1	R2	R3	R4	R5	R6
0200	1.396	1.067	562	1.018	157	249	118	147	239	108
0220	1.393	1.070	561	1.024	158	250	118	149	241	108
0240	1.387	1.066	561	1.037	162	254	119	151	243	108

IPJ	CK assembly									
	Centre of gravity (mm)			Weight (kg)	Reactions in the supports (kg)					
	X	Y	Z		R1	R2	R3	R4	R5	R6
0200	1.476	1.138	622	1.119	144	262	134	157	274	147
0220	1.476	1.138	622	1.119	144	262	134	157	274	147
0240	1.467	1.131	620	1.138	150	267	136	160	278	146

IPJ	CA assembly									
	Centre of gravity (mm)			Weight (kg)	Reactions in the supports (kg)					
	X	Y	Z		R1	R2	R3	R4	R5	R6
0200	1.494	1.153	608	1.162	143	269	141	162	288	159
0220	1.491	1.155	607	1.168	144	270	140	164	290	160
0240	1.485	1.151	606	1.180	148	274	141	166	292	159

IPJ	CP assembly									
	Centre of gravity (mm)			Weight (kg)	Reactions in the supports (kg)					
	X	Y	Z		R1	R2	R3	R4	R5	R6
0200	1.512	1.167	609	1.192	140	273	146	165	298	170
0220	1.509	1.170	608	1.198	141	274	145	167	300	171
0240	1.503	1.165	607	1.210	145	278	146	169	302	170

IPJ	CR assembly									
	Centre of gravity (mm)			Weight (kg)	Reactions in the supports (kg)					
	X	Y	Z		R1	R2	R3	R4	R5	R6
0200	1487	1204	607	1.283	149	287	143	191	328	185
0220	1484	1206	606	1.289	150	288	143	193	330	185
0240	1479	1201	605	1.301	154	291	144	195	332	185

IPJ	CQ assembly									
	Centre of gravity (mm)			Weight (kg)	Reactions in the supports (kg)					
	X	Y	Z		R1	R2	R3	R4	R5	R6
0200	1.565	1.047	796	1.285	164	320	195	140	296	171
0220	1.565	1.047	796	1.285	164	320	195	140	296	171
0240	1.556	1.042	792	1.304	169	325	196	143	299	170

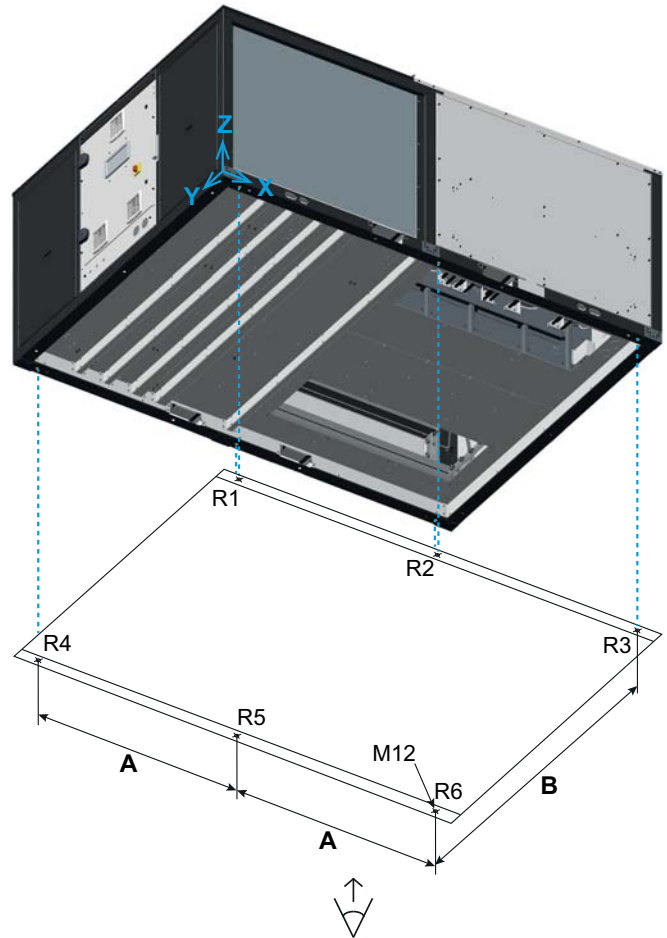

IPJ	Distances (mm)	
	A	B
0200 to 0240	1.356	2.108

IPJ	CT assembly									
	Centre of gravity (mm)			Weight (kg)	Reactions in the supports (kg)					
	X	Y	Z		R1	R2	R3	R4	R5	R6
0200	1523	1068	789	1.376	182	338	193	166	322	177
0220	1520	1070	787	1.376	182	337	192	167	322	177
0240	1514	1067	785	1.395	186	343	194	170	326	177

IPJ	CW assembly									
	Centre of gravity (mm)			Weight (kg)	Reactions in the supports (kg)					
	X	Y	Z		R1	R2	R3	R4	R5	R6
0200	1.661	1.515	696	1.542	153	368	245	157	371	248
0220	1.658	1.516	695	1.548	155	369	245	158	373	249
0240	1.652	1.509	694	1.561	159	374	247	160	374	247



## CENTRE OF GRAVITY AND REACTIONS IN THE SUPPORTS: IPJ SERIES

### Cross flow

IPJ	C0 assembly									
	Centre of gravity (mm)			Weight (kg)	Reactions in the supports (kg)					
	X	Y	Z		R1	R2	R3	R4	R5	R6
0280	1.628	1.054	564	1.146	191	283	124	174	266	107
0320	1.628	1.054	564	1.146	191	283	124	174	266	107
0360	1.644	1.055	572	1.135	186	280	125	170	264	109
0380	1.634	1.048	569	1.160	193	287	128	174	268	109

IPJ	CS assembly									
	Centre of gravity (mm)			Weight (kg)	Reactions in the supports (kg)					
	X	Y	Z		R1	R2	R3	R4	R5	R6
0280	1.659	1.080	563	1.181	187	287	128	179	279	121
0320	1.659	1.080	563	1.181	187	287	128	179	279	121
0360	1.667	1.074	569	1.190	188	290	132	178	280	122
0380	1.664	1.074	568	1.195	189	291	132	179	281	122

IPJ	CK assembly									
	Centre of gravity (mm)			Weight (kg)	Reactions in the supports (kg)					
	X	Y	Z		R1	R2	R3	R4	R5	R6
0280	1.749	1.139	624	1.308	178	306	148	193	321	163
0320	1.749	1.139	624	1.308	178	306	148	193	321	163
0360	1.750	1.139	629	1.308	178	306	148	193	321	163
0380	1.747	1.139	629	1.313	179	307	148	194	322	163

IPJ	CA assembly									
	Centre of gravity (mm)			Weight (kg)	Reactions in the supports (kg)					
	X	Y	Z		R1	R2	R3	R4	R5	R6
0280	1.784	1.168	608	1.359	172	312	154	200	340	182
0320	1.784	1.168	608	1.359	172	312	154	200	340	182
0360	1.790	1.162	613	1.368	173	315	158	199	341	183
0380	1.787	1.161	612	1.373	174	316	158	200	342	183

IPJ	CP assembly									
	Centre of gravity (mm)			Weight (kg)	Reactions in the supports (kg)					
	X	Y	Z		R1	R2	R3	R4	R5	R6
0280	1.798	1.171	611	1.387	172	317	159	202	347	190
0320	1.798	1.171	611	1.387	172	317	159	202	347	190
0360	1.798	1.172	616	1.387	172	317	159	202	348	190
0380	1.795	1.171	615	1.392	173	318	159	203	349	190

IPJ	CR assembly									
	Centre of gravity (mm)			Weight (kg)	Reactions in the supports (kg)					
	X	Y	Z		R1	R2	R3	R4	R5	R6
0280	1781	1208	611	1.490	180	333	160	228	381	208
0320	1781	1208	611	1.490	180	333	160	228	381	208
0360	1786	1202	615	1.490	180	334	162	226	380	208
0380	1784	1201	615	1.495	181	335	162	227	381	208

IPJ	CQ assembly									
	Centre of gravity (mm)			Weight (kg)	Reactions in the supports (kg)					
	X	Y	Z		R1	R2	R3	R4	R5	R6
0280	1.852	1.058	787	1.482	199	366	210	177	344	187
0320	1.852	1.058	787	1.482	199	366	210	177	344	187
0360	1.857	1.053	791	1.491	200	370	213	175	345	189
0380	1.855	1.053	789	1.496	201	371	213	176	346	188

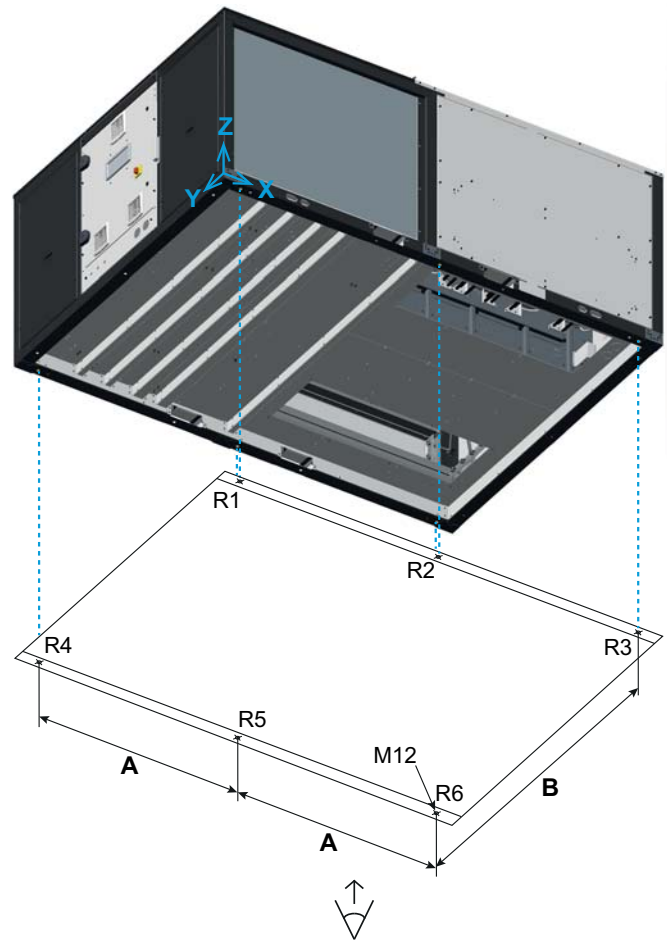

IPJ	Distances (mm)	
	A	B
0280 to 0380	1.683	2.108

IPJ	CT assembly									
	Centre of gravity (mm)			Weight (kg)	Reactions in the supports (kg)					
	X	Y	Z		R1	R2	R3	R4	R5	R6
0280	1831	1090	771	1.585	209	384	211	202	376	203
0320	1831	1090	771	1.585	209	384	211	202	376	203
0360	1836	1085	775	1.594	211	387	214	201	377	205
0380	1833	1085	774	1.599	212	388	215	202	378	205

IPJ	CW assembly									
	Centre of gravity (mm)			Weight (kg)	Reactions in the supports (kg)					
	X	Y	Z		R1	R2	R3	R4	R5	R6
0280	1.976	1.513	692	1.771	190	423	268	193	426	271
0320	1.976	1.513	692	1.771	190	423	268	193	426	271
0360	1.979	1.506	695	1.780	192	427	272	191	426	272
0380	1.977	1.505	694	1.785	194	428	273	192	427	271

**CENTRE OF GRAVITY AND REACTIONS IN THE SUPPORTS: IPJ SERIES**

**Tunnel flow**

IPJ	T0 assembly									
	Centre of gravity (mm)			Weight (kg)	Reactions in the supports (kg)					
	X	Y	Z		R1	R2	R3	R4	R5	R6
0200	1.402	1.104	569	1.044	154	249	116	156	251	118
0220	1.399	1.107	568	1.050	155	250	116	158	253	118
0240	1.393	1.103	568	1.062	159	254	117	160	255	118
0280	1.607	1.106	571	1.179	191	282	114	193	284	116
0320	1.607	1.106	571	1.179	191	282	114	193	284	116
0360	1.608	1.106	578	1.189	192	284	115	194	286	118
0380	1.606	1.106	577	1.193	193	285	115	195	287	118

IPJ	TS assembly									
	Centre of gravity (mm)			Weight (kg)	Reactions in the supports (kg)					
	X	Y	Z		R1	R2	R3	R4	R5	R6
0200	1.461	1.103	570	1.082	148	259	133	149	260	134
0220	1.458	1.106	569	1.088	149	260	132	151	262	134
0240	1.452	1.102	569	1.101	153	263	133	153	264	134
0280	1.658	1.104	571	1.216	188	291	127	189	292	129
0320	1.658	1.104	571	1.216	188	291	127	189	292	129
0360	1.659	1.105	577	1.225	189	293	128	191	295	130
0380	1.657	1.105	576	1.230	190	294	129	192	296	130

IPJ	TP assembly									
	Centre of gravity (mm)			Weight (kg)	Reactions in the supports (kg)					
	X	Y	Z		R1	R2	R3	R4	R5	R6
0200	1.732	1.103	535	1.252	209	299	116	210	300	117
0220	1.728	1.105	534	1.258	210	300	115	212	302	117
0240	1.720	1.101	535	1.270	215	304	115	215	305	116
0280	1.866	1.103	615	1.405	175	337	191	175	336	191
0320	1.866	1.103	615	1.405	175	337	191	175	336	191
0360	1.866	1.104	620	1.414	176	339	192	176	339	192
0380	1.863	1.103	619	1.419	178	340	193	177	340	192

IPJ	TW assembly (machine + recovery module)							
	Centre of gravity: machine (mm)			Centre of gravity: module (mm)			Machine weight (kg)	Module weight (kg)
	X	Y	Z	X	Y	Z		
0200	1.345	1.105	568	905	1.093	864	1.029	719
0220	1.342	1.108	567	905	1.093	864	1.035	719
0240	1.337	1.103	567	905	1.093	864	1.048	719
0280	2.364	1.102	693	--	--	--	1.358	454
0320	2.364	1.102	693	--	--	--	1.358	454
0360	2.362	1.103	697	--	--	--	1.367	454
0380	2.358	1.102	696	--	--	--	1.372	454

IPJ	TW assembly (machine + recovery module)										
	Total weight (kg)	Reactions in the supports (kg)									
		R1	R2	R3	R4	R5	R6	R7	R8	R9	R10
0200	1.749	142	247	127	141	246	126	150	214	209	146
0220	1.755	143	248	127	143	248	127	150	214	209	146
0240	1.767	146	252	128	145	250	127	150	214	209	146
0280	1.812	201	435	272	200	433	271	--	--	--	--
0320	1.812	201	435	272	200	433	271	--	--	--	--
0360	1.822	203	437	273	202	436	271	--	--	--	--
0380	1.826	204	438	273	203	437	271	--	--	--	--

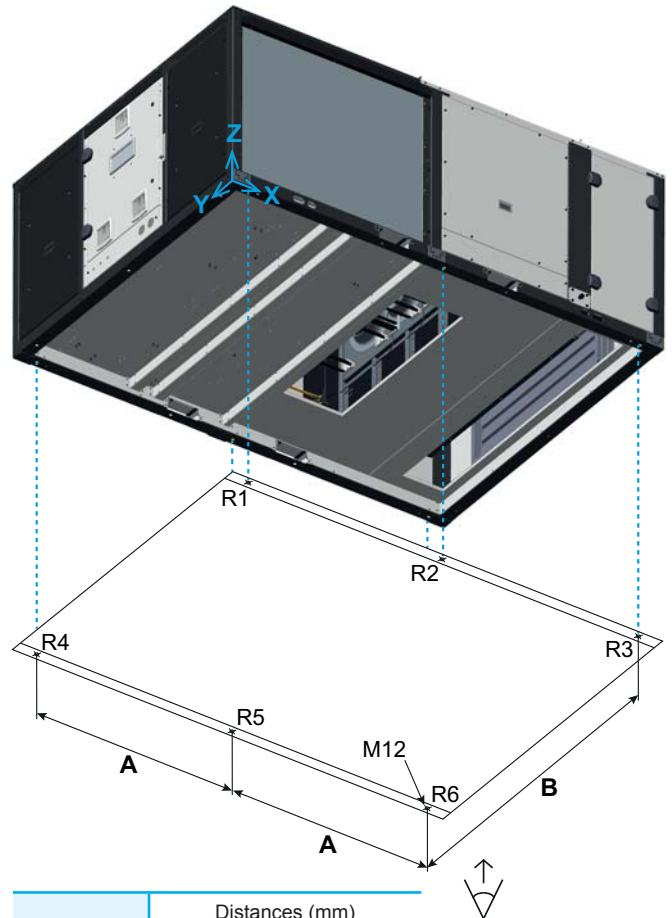

IPJ	Distances (mm)			
	A	B	C	D
0200 to 0240	1.356	2.108	766	1.916
0280 to 0380	1.683	2.108	--	--

**IPJ - 0200 to 0240: TW assembly**  
Recovery module connected to the machine

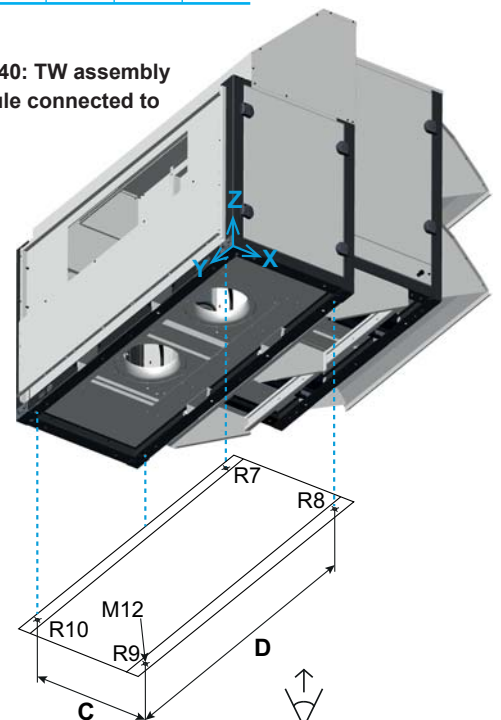

## RECOMMENDED SERVICE CLEARANCE

Vectios™ PJ - 0090 to 0190: C0, CS, CK, CA, CP, CR, CQ and CT assemblies

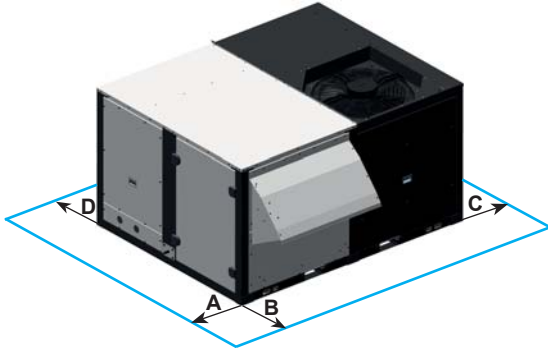

Distances	A	B	C	D
0090 to 0190 (mm)	1.200	1.000	1.000	1.600

Vectios™ PJ - 0090 to 0190: CW assembly

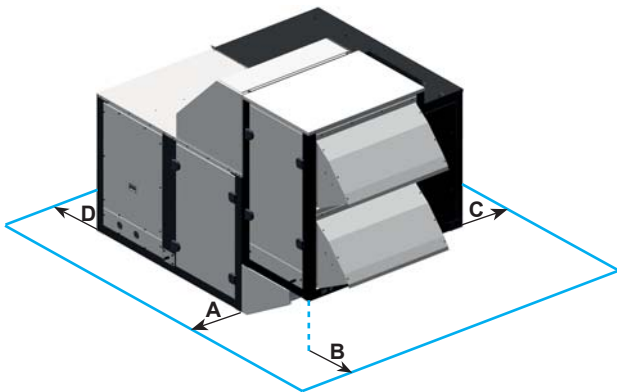

Distances	A	B	C	D
0090 to 0190 (mm)	1.200	1.000	1.000	1.600

Vectios™ PJ - 0200 to 0380: C0, CS, CK, CA, CP, CR, CQ and CT assemblies

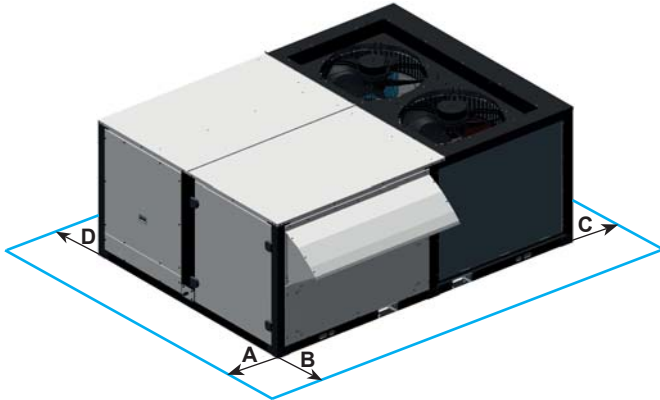

Distances	A	B	C	D
0200 to 0240 (mm)	1.600	1.000	1.000	1.000
0280 to 0380 (mm)	2.000	1.000	1.000	1.000

Vectios™ PJ - 0200 to 0380: CW assembly

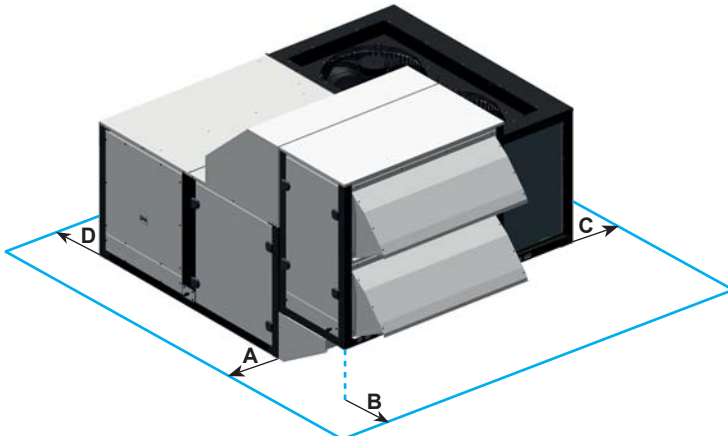

Distances	A	B	C	D
0200 to 0240 (mm)	1.600	1.000	1.000	1.000
0280 to 0380 (mm)	2.000	1.000	1.000	1000

Note: Unit not designed to have overhead obstruction.

## RECOMMENDED SERVICE CLEARANCE

Vectios™ PJ - 0200 to 0380: T0 and TS assemblies

Vectios™ PJ - 0280 to 0380: TP assembly

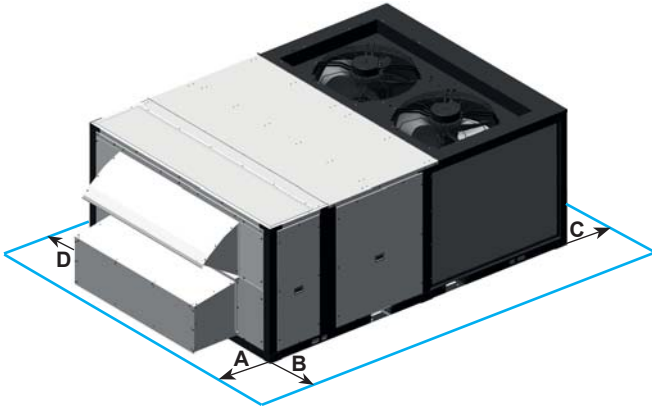

Distances	A	B	C	D
0200 to 0240 (mm)	1.000	1.000	1.300	2.200
0280 to 0380 (mm)	1.000	1.000	1.600	2.200

Vectios™ PJ - 0200 to 0240: TP assembly

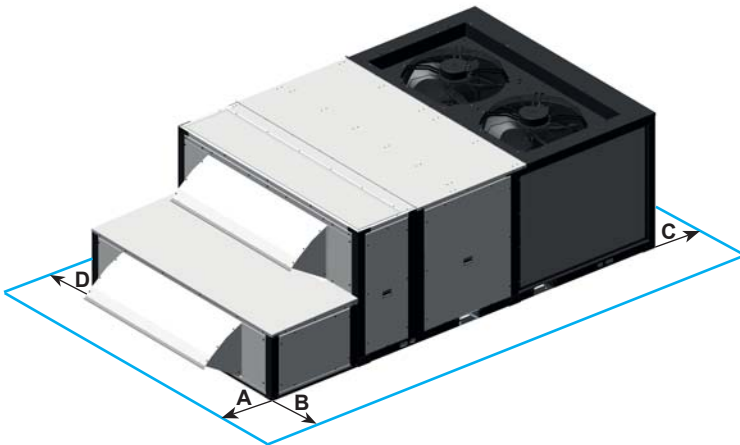

Distances	A	B	C	D
0200 to 0240 (mm)	1.000	1.000	1.300	2.200

Vectios™ PJ - 0200 to 0380: TW assembly

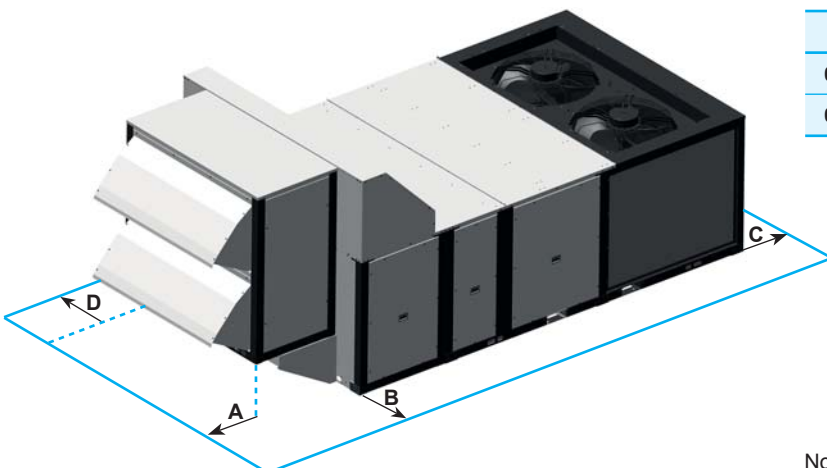

Distances	A	B	C	D
0200 to 0240 (mm)	1.000	1.000	1.300	2.200
0280 to 0380 (mm)	1.000	1.000	1.600	2.200

Note: Unit not designed to have overhead obstruction.

## PRE-ASSEMBLY ROOFCURBS

### Adjustable roofcurbs (for “Cross Flow” assemblies)

- ➔ ② Standard indoor air circulation
- ⑥ Standard air supply
- ⑧ Standard air return

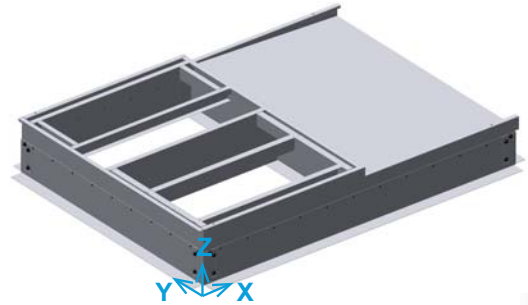
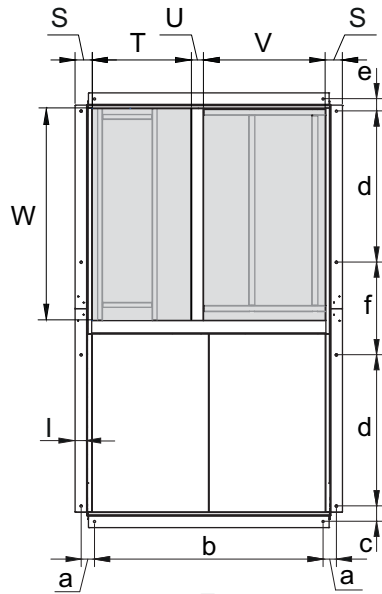

PJ roofcurb	Weight (kg)	Centre of gravity (mm)			Maximum slope	
		X	Y	Z	$\alpha$	$\beta$
0090 to 0190	145	864	870	194	4° (7,0%)	3° (5,1%)
0200 to 0240	205	1.422	1.100	202	4° (7,0%)	3° (5,5%)
0280 to 0380	237	1.757	1.102	200	4° (7,0%)	2° (4,0%)

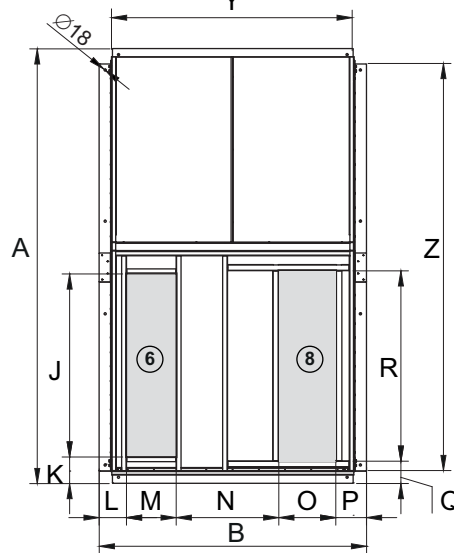
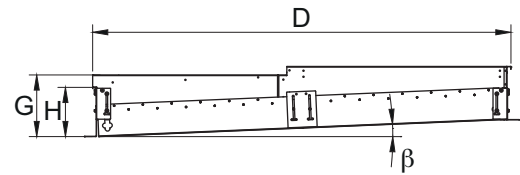
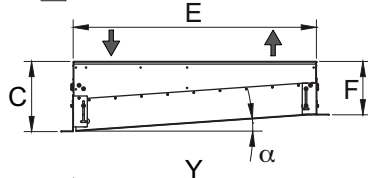
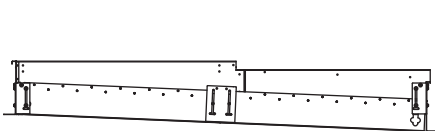

Dimensions	A	B	C	D	E	F	G	H	I	J	K	L	M	N	O	P
0090 to 0190 (mm)	2.163	1.759	547	2.026	1.560	440	477	375	95	848	143	183	297	721	376	182
0200 to 0240 (mm)	2.933	2.205	578	2.796	2.006	440	508	406	95	1.210	175	226	410	846	470	253
0280 to 0380 (mm)	3.586	2.205	578	3.450	2.006	440	508	406	95	1.510	219	226	410	846	470	253

Dimensions	Q	R	S	T	U	V	W	Y	Z	a	b	c	d	e	f
0090 to 0190 (mm)	148	830	142	817	100	558	907	1.539	1.938	110	1.439	123	919	101	0
0200 to 0240 (mm)	165	1.230	142	817	100	1.004	1.349	1.985	2.707	110	1.885	125	1.303	101	0
0280 to 0380 (mm)	184	1.570	142	817	100	1.004	1.749	1.985	3.358	110	1.885	127	1.247	101	764

Note: Drawings without scale. Refer to the certified dimensional drawings available on request, when designing an installation.

**PRE-ASSEMBLY ROOFCURBS**

**Adjustable roofcurbs with gas burner (for “Cross Flow” assemblies)**

- Standard indoor air circulation
- ⑥ Standard air supply
- ⑧ Standard air return
- ⑮ Burner drainage 1/2”M
- ⑯ Gas supply 3/4”M
- ⑰ Flue outlet, internal Ø 80mm (Flue connection)

**Important:** The flue of the gas burner is not supplied with the unit. Its design and installation is the responsibility of the installer and must comply with all the directives and regulations in force in the installation location.

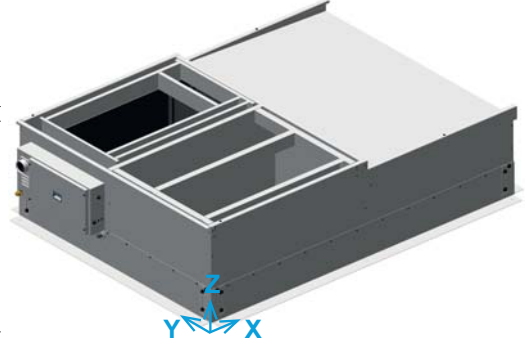
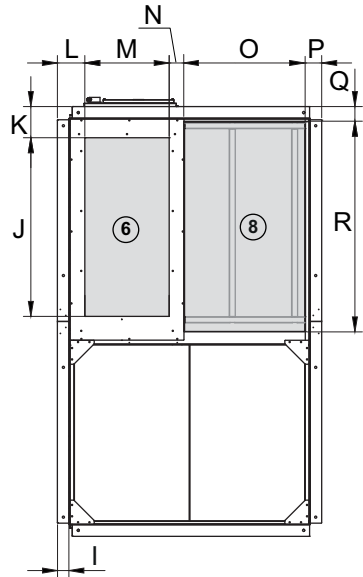

PJ burner roofcurb	Weight (kg)	Centre of gravity (mm)			Maximum slope	
		X	Y	Z	α	β
0090 to 0190	284	885	881	338	4° (7,0%)	3° (5,1%)
0200 to 0240	411	1.214	1.277	344	4° (7,0%)	3° (5,5%)
0280 to 0380	483	1.492	1.289	348	4° (7,0%)	2° (4,0%)

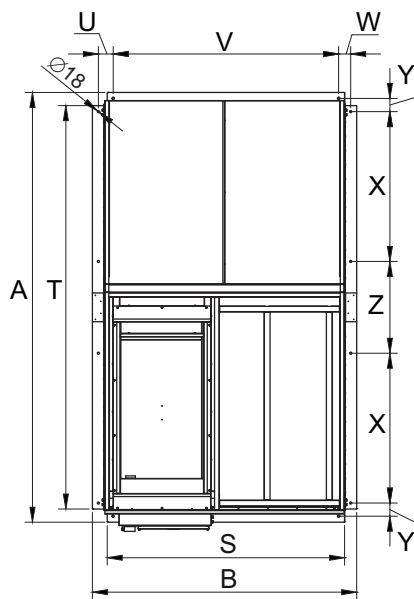
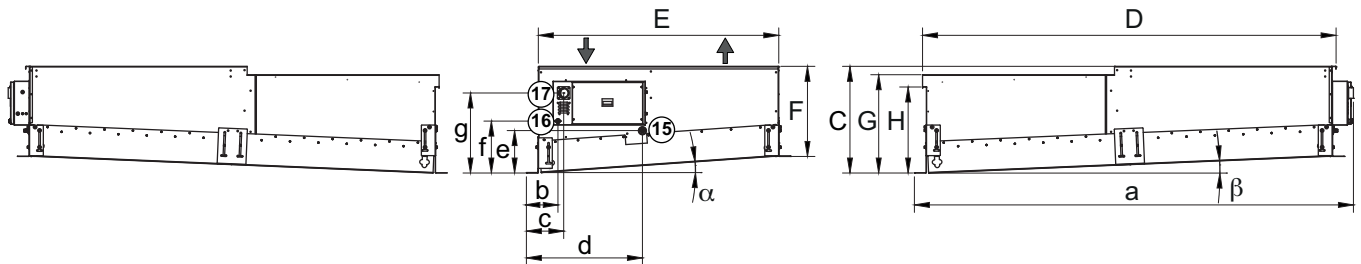

Dimensions	Burner	a	b	c	d	e	f	g
0090 to 0190 (mm)	PCH020 PCH034	2.239	313	364	862	321	400	635
	PCH045	2.239	313	364	933	321	400	635
0200 to 0240 (mm)	PCH065	3.009	263	314	883	354	433	668
	PCH080	3.009	263	314	968	354	433	668
0280 to 0380 (mm)	PCH080 PCH105	3.663	263	314	968	354	433	668

Dimensions	A	B	C	D	E	F	G	H	I	J	K	L	M	N	O	P	Q	R	S	T	U	V	W	X	Y	Z
0090 to 0190 (mm)	2.163	1.759	857	2.026	1.560	750	787	685	95	770	261	142	686	231	558	142	133	907	1.535	1.943	122	1.435	101	922	110	0
0200 to 0240 (mm)	2.933	2.205	890	2.796	2.006	750	820	718	95	1.219	261	230	619	210	1.004	142	133	1.349	1.980	2.713	124	1.880	101	1.307	110	0
0280 to 0380 (mm)	3.586	2.205	890	3.450	2.006	750	820	718	95	1.491	260	229	704	126	1.004	142	133	1.749	1.980	3.366	124	1.880	101	1.250	110	766

Note: Drawings without scale. Refer to the certified dimensional drawings available on request, when designing an installation.

**DIMENSIONAL DRAWINGS WITH GAS BOILER**

**PJ - 0090 / 0120 / 0140 / 0160 / 0180 / 0190, CS assembly and gas burner**

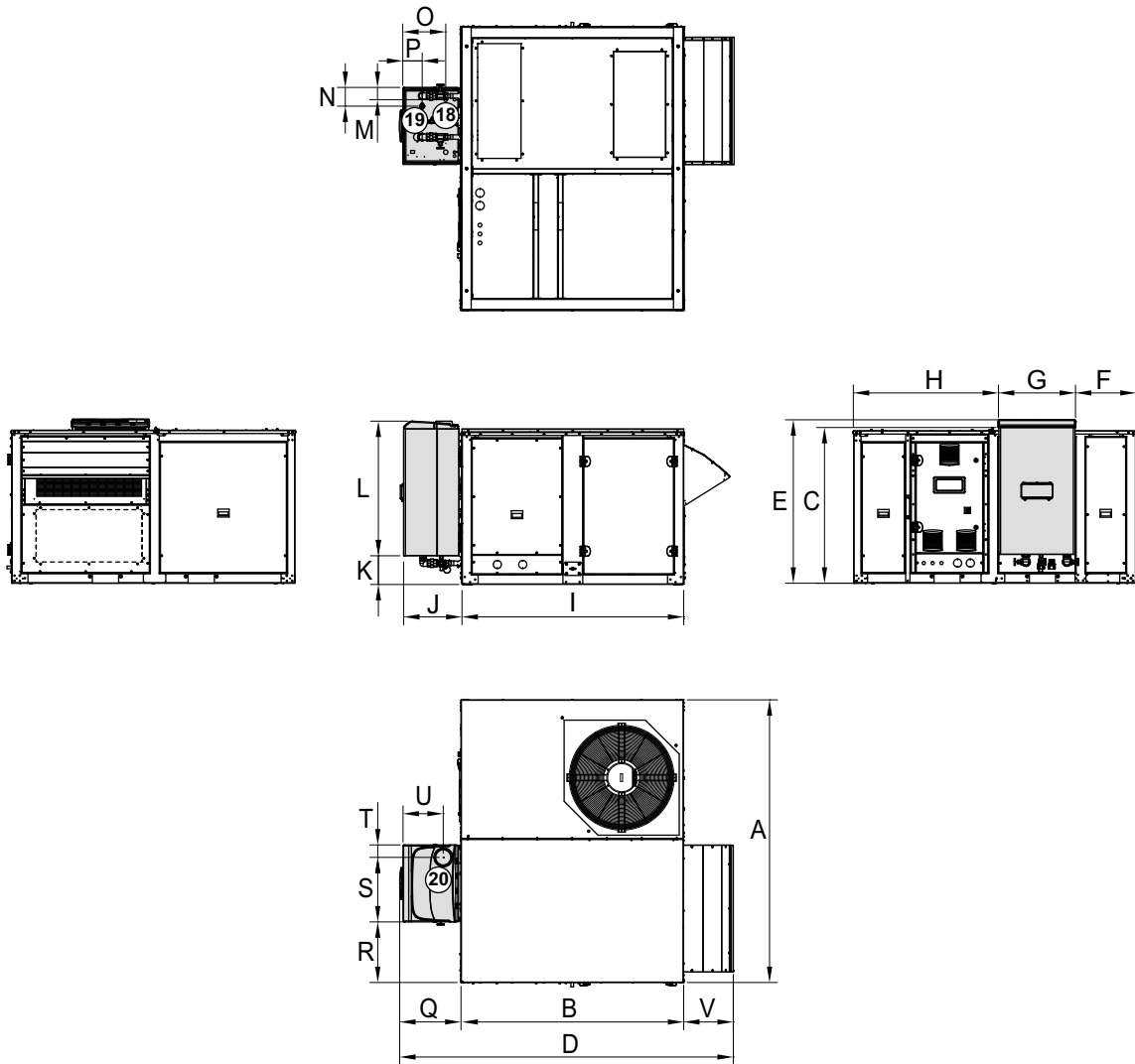

- ⑱ Boiler drainage Ø 25mm  
**Important: Siphon minimum height 300mm**
- ⑲ Gas supply 1" M
- ⑳ Flue outlet (flue connection):  
Condexa PRO 40 / 50 / 70: Ø 80mm

**Important:** The flue of the gas boiler is not supplied with the unit. Its design and installation is the responsibility of the installer and must comply with all the directives and regulations in force in the installation location.

Dimensions	L x W x H			D	E	F	G	H	I	J	K	L	M	N	O	P	Q	R	S	T	U	V
	A	B	C																			
<b>0090 to 0190 (mm)</b>	2.225	1.750	1.230	2.624	1.286	477	606	1.141	1.744	459	226	1.060	96	147	338	157	482	477	508	98	316	392

Note: Drawings without scale. Refer to the certified dimensional drawings available on request, when designing an installation.

**DIMENSIONAL DRAWINGS WITH GAS BOILER**

**PJ - 0200 / 0220 / 0240 / 0280 / 0320 / 0360 / 0380, CS assembly and gas burner**

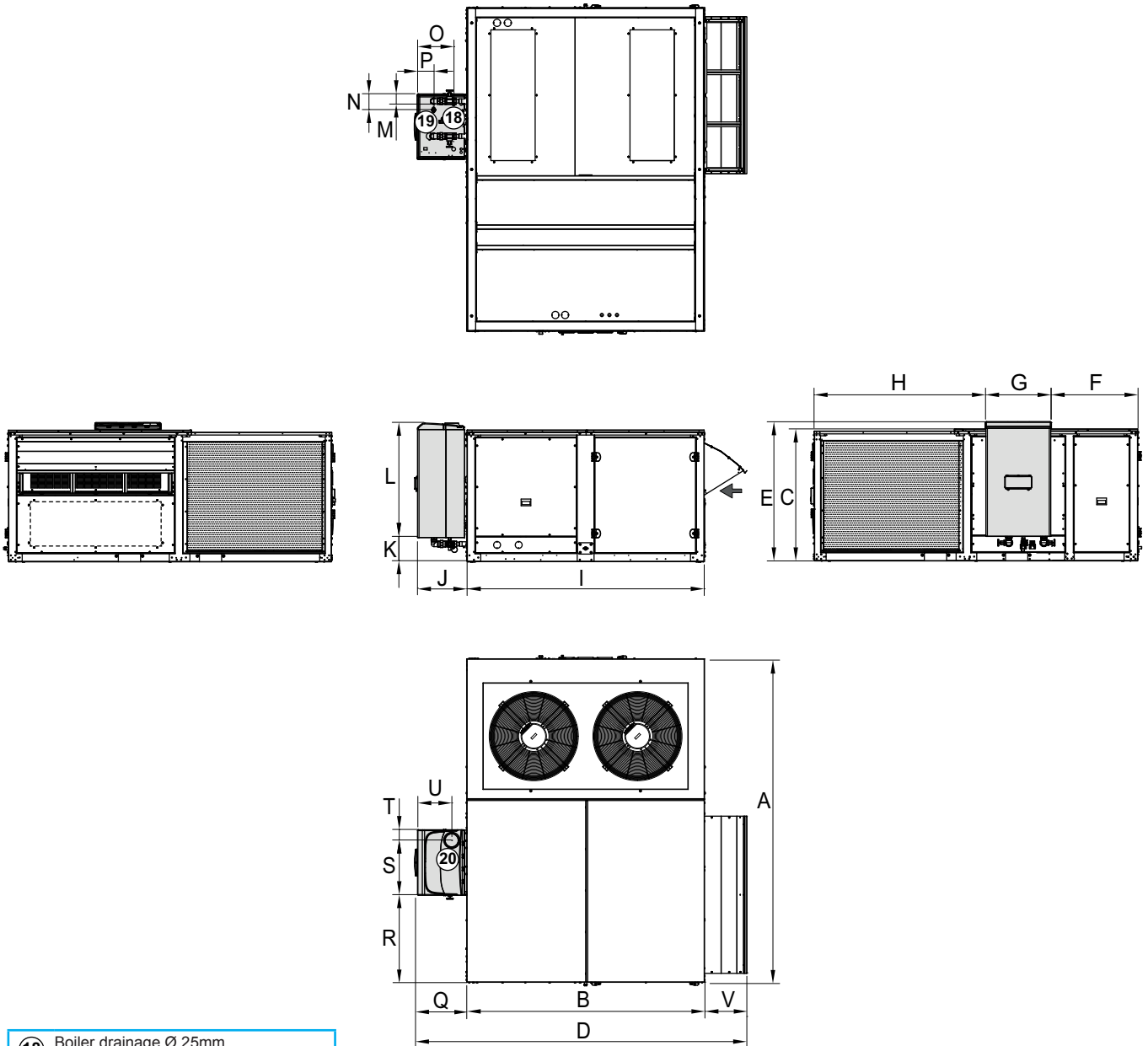

- ⑱ Boiler drainage Ø 25mm  
**Important: Siphon minimum height 300mm**
- ⑲ Gas supply 1" M
- ⑳ Flue outlet (flue connection):  
Condexa PRO 50 / 70: Ø 80mm  
Condexa PRO 100: Ø 110 mm

**Important:** The flue of the gas boiler is not supplied with the unit. Its design and installation is the responsibility of the installer and must comply with all the directives and regulations in force in the installation location.

Dimensions	L x W x H				D	E	F	G	H	I	J	K	L	M	N	O	P	Q	R	S	T	U	V
	A	B	C																				
<b>0200 to 0240 (mm)</b>	3.000	2.200	1.230		3.074	1.286	803	606	1.584	2.195	459	226	1.060	96	147	338	157	482	803	508	98	316	392
<b>0280 to 0380 (mm)</b>	3.650	2.200	1.230		3.074	1.286	1.183	606	1.858	2.195	459	226	1.060	96	147	338	157	482	1.183	508	98	316	392

Note: Drawings without scale. Refer to the certified dimensional drawings available on request, when designing an installation.



## DIMENSIONAL DRAWINGS WITH GAS BOILER

**PJ - 0200 / 0220 / 0240 / 0280 / 0320 / 0360 / 0380, TS assembly and gas burner**

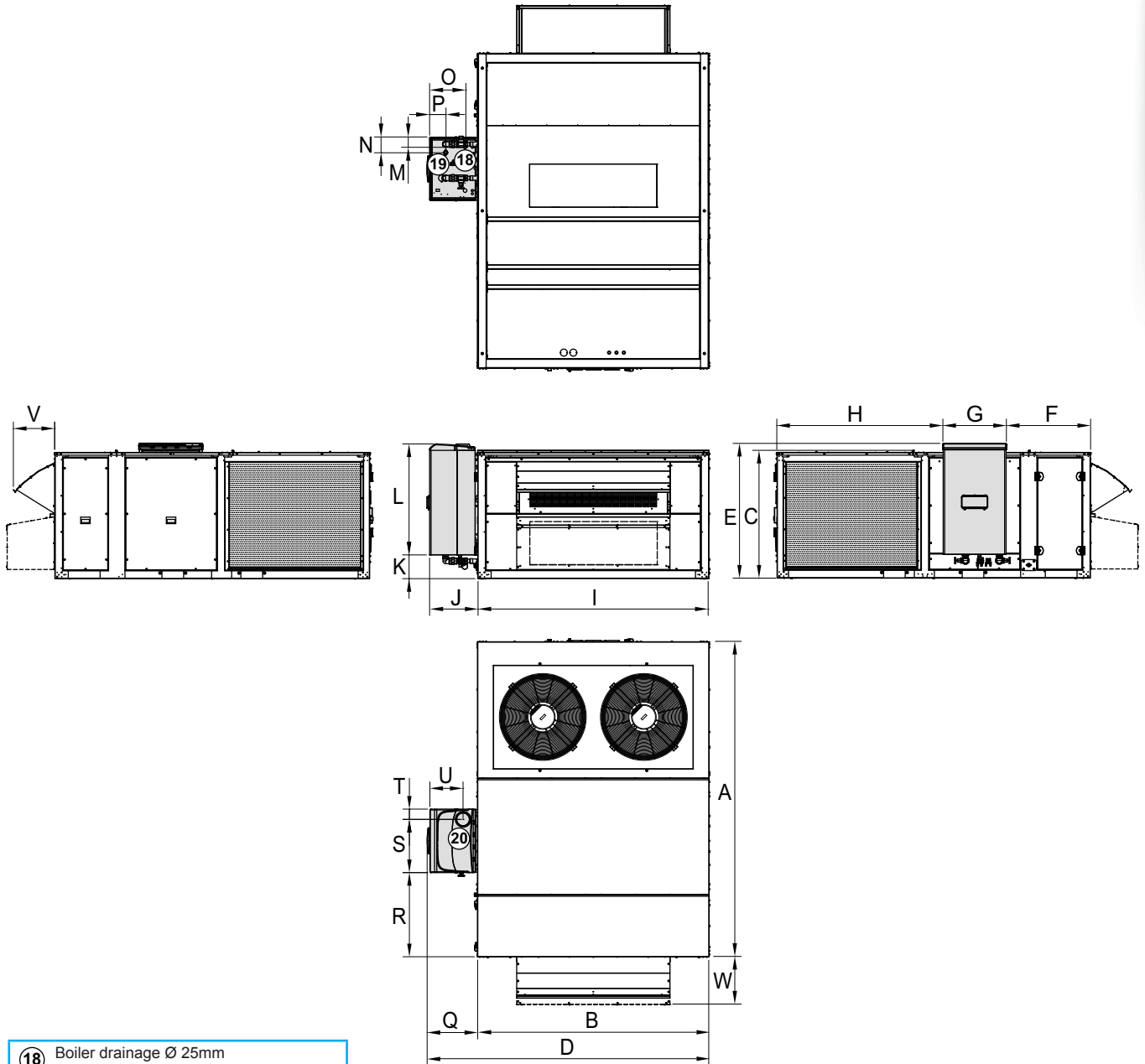

- ⑱ Boiler drainage Ø 25mm  
**Important: Siphon minimum height 300mm**
- ⑲ Gas supply 1" M
- ⑳ Flue outlet (flue connection):  
Condexa PRO 50 / 70: Ø 80mm  
Condexa PRO 100: Ø 110 mm

**Important:** The flue of the gas boiler is not supplied with the unit. Its design and installation is the responsibility of the installer and must comply with all the directives and regulations in force in the installation location.

Dimensions	L x W x H			D	E	F	G	H	I	J	K	L	M	N	O	P	Q	R	S	T	U	V	W
	A	B	C																				
<b>0200 to 0240 (mm)</b>	3.000	2.200	1.230	2.682	1.286	803	606	1.584	2.195	459	226	1.060	459	226	1.060	157	482	803	508	98	316	392	452
<b>0280 to 0380 (mm)</b>	3.650	2.200	1.230	2.682	1.286	1.373	606	1.699	2.195	459	226	1.060	459	226	1.060	157	482	1.373	508	98	316	392	--

Note: Drawings without scale. Refer to the certified dimensional drawings available on request, when designing an installation.

**WEIGHT OVERVIEW OF THE VARIOUS ASSEMBLIES AND THE MAIN OPTIONS (kg)**

RPJ series		0090	0120	0140	0160	0180	0190	0200	0220	0240	0280	0320	0360	0380
C0 assembly		594	617	699	698	704	701	914	929	936	1.035	1.059	1.057	1.078
C5 assembly		609	632	718	718	718	720	946	967	969	1.070	1.094	1.112	1.113
CK assembly		682	705	796	796	796	798	1.047	1.062	1.070	1.197	1.221	1.230	1.231
CA assembly		713	736	815	815	815	817	1.090	1.111	1.112	1.248	1.272	1.290	1.291
CP assembly		723	746	831	831	828	833	1.120	1.141	1.142	1.276	1.300	1.309	1.310
CR assembly		781	804	900	900	897	902	1.211	1.232	1.233	1.379	1.403	1.412	1.413
CQ assembly		774	797	882	882	882	884	1.213	1.228	1.236	1.371	1.395	1.413	1.414
CT assembly		832	855	951	951	951	953	1.304	1.319	1.327	1.474	1.498	1.516	1.517
CW assembly	Machine	722	745	834	834	834	837	1.122	1.143	1.145	1.206	1.230	1.248	1.249
	Recovery module	254	254	254	254	254	254	348	348	348	454	454	454	454
	Total weight	976	999	1.088	1.088	1.088	1.091	1.470	1.491	1.493	1.660	1.684	1.702	1.703
T0 assembly		--	--	--	--	--	--	972	993	994	1.068	1.092	1.111	1.111
TS assembly		--	--	--	--	--	--	1.010	1.031	1.033	1.105	1.129	1.147	1.148
TP assembly		--	--	--	--	--	--	1.180	1.201	1.202	1.294	1.318	1.336	1.337
TW assembly	Machine	--	--	--	--	--	--	957	978	980	1.247	1.271	1.289	1.290
	Recovery module	--	--	--	--	--	--	719	719	719	454	454	454	454
	Total weight	--	--	--	--	--	--	1.676	1.697	1.699	1.701	1.725	1.743	1.744
IPJ series		0090	0120	0140	0160	0180	0190	0200	0220	0240	0280	0320	0360	0380
C0 assembly		594	617	699	698	704	701	986	986	1.004	1.146	1.146	1.135	1.160
C5 assembly		609	632	718	718	718	720	1.018	1.024	1.037	1.181	1.181	1.190	1.195
CK assembly		682	705	796	796	796	798	1.119	1.119	1.138	1.308	1.308	1.308	1.313
CA assembly		713	736	815	815	815	817	1.162	1.168	1.180	1.359	1.359	1.368	1.373
CP assembly		723	746	831	831	828	833	1.192	1.198	1.210	1.387	1.387	1.387	1.392
CR assembly		781	804	900	900	897	902	1.283	1.289	1.301	1.490	1.490	1.490	1.495
CQ assembly		774	797	882	882	882	884	1.285	1.285	1.304	1.482	1.482	1.491	1.496
CT assembly		832	855	951	951	951	953	1.376	1.376	1.395	1.585	1.585	1.594	1.599
CW assembly	Machine	722	745	834	834	834	837	1.194	1.200	1.213	1.317	1.317	1.326	1.331
	Recovery module	254	254	254	254	254	254	348	348	348	454	454	454	454
	Total weight	976	999	1.088	1.088	1.088	1.091	1.542	1.548	1.561	1.771	1.771	1.780	1.785
T0 assembly		--	--	--	--	--	--	1.044	1.050	1.062	1.179	1.179	1.189	1.193
TS assembly		--	--	--	--	--	--	1.082	1.088	1.101	1.216	1.216	1.225	1.230
TP assembly		--	--	--	--	--	--	1.252	1.258	1.270	1.405	1.405	1.414	1.419
TW assembly	Machine	--	--	--	--	--	--	1029	1035	1048	1358	1358	1367	1372
	Recovery module	--	--	--	--	--	--	719	719	719	454	454	454	454
	Total weight	--	--	--	--	--	--	1.749	1.755	1.767	1.812	1.812	1.822	1.826

**Weight supplement from the main options (kg)**

Vectios™ PJ			0090	0120	0140	0160	0180	0190	0200	0220	0240	0280	0320	0360	0380
Pre-assembly roofcurb (without gas burner)			145	145	145	145	145	145	205	205	205	237	237	237	237
Pre-assembly roofcurb (with gas burner)	G0L (Low)		265	265	265	265	265	--	--	--	--	--	--	--	--
	G0N (Nominal)		274	274	274	274	274	274	385	385	385	463	463	463	463
	G0H (High)		284	284	284	284	284	284	411	411	411	483	483	483	483
Electrical heaters	E0L (Low)		20	20	20	20	20	20	17	17	17	17	17	17	17
	E0N (Nominal)		17	17	17	17	17	17	21	21	21	21	21	21	21
	E0H (High)		--	--	21	21	21	21	25	25	25	25	25	25	25
Hot water coil	Standard	Empty	33	33	37	37	37	37	51	51	51	58	58	58	58
		Service	40	40	46	46	46	46	67	67	67	78	78	78	78
	Great cold	Empty	41	41	45	45	45	45	71	71	71	78	78	78	78
		Service	49	49	55	55	55	55	89	89	89	100	100	100	100
Boiler + Hot water coil	Boiler		69	69	69	69	69	69	69	69	69	69	69	69	69
	Water circuit	Empty	47	47	52	52	52	52	79	79	79	87	87	87	87
		Service	55	55	62	62	62	62	98	98	98	109	109	109	109
	Total service weight			124	124	131	131	131	131	167	167	167	178	178	178
Heat recovery coil	Empty		22	22	21	21	21	21	30	30	30	36	36	36	36
	Service		31	31	31	31	31	31	44	44	44	53	53	53	53
Supply fan	Low pressure (L)		-7	-7	--	--	--	--	-21	-21	-21	-9	-9	-9	-9
	High pressure (H)		--	--	28	28	28	28	38	38	38	29	29	29	29
Stop-drop	Indoor coil		24	24	25	25	25	25	34	34	34	43	43	43	43
	Fresh air intake		8	8	8	8	8	8	11	11	11	14	14	14	14
Centrifugal return fan (CQ and CT assemblies)	1: Low flow + nominal pressure		-8	-7	7	10	10	10	-21	-21	-21	20	20	20	20
	2: Low flow + high pressure		-1	3	31	31	31	31	0	10	10	30	30	30	30
	3: Nominal flow + nominal pressure		-7	7	13	17	17	17	-1	-1	-1	47	47	47	47
	4: Nominal flow + high pressure		3	9	38	38	38	38	26	26	26	145	145	145	145
	5: High flow + nominal pressure		0	13	17	36	36	36	20	27	27	60	60	60	60
	6: High flow + high pressure		9	15	48	63	48	48	44	44	44	145	145	185	185



