

Air-air and
water-air units

COMMUNICATIONS BROCHURE

NA 14.729 B 01 - 2016

Electronic control

CIATrTc

Installation and
configuration



Contents

Connection of units with CIATrtc control to a local communications network (pLAN)

1. Technical characteristics of a pLAN.....	5
2. Components of the pLAN.....	6
2.1. Minimal configuration.....	6
2.2. Additional elements.....	6
3. Connection of the pLAN.....	6
3.1. Connection of the µPC MEDIUM boards.....	6
3.2. Connection of the pGD1 terminals.....	7
4. Configuration of the pLAN.....	8
4.1. Addressing of the µPC MEDIUM boards.....	8
4.2. Configuration of the common terminal.....	9
4.3. Assignment of the terminals for each µPC MEDIUM board.....	9
4.4. Configuration of independent units.....	11
4.5. Configuration of the common probes (optional).....	11
5. Monitoring of the pLAN.....	12
5.1. Viewing the terminal's connection status.....	12
5.2. Network status view.....	12

Connection of units with CIATrtc control to a Supervisory System (BMS)

1. Communication protocols.....	13
2. Supervision solutions.....	14
3. RS485 supervisory network.....	14
4. ETHERNET supervisory network.....	15
5. Configuration of the supervisory network.....	16
5.1. Enabling of the supervisory network.....	16
5.2. Selection of the supervisory type.....	16
5.3. Addressing of the µPC MEDIUM boards on the supervisory network.....	17
6. Carel and Modbus supervisory variables.....	18
6.1. Equivalence between the Carel and Modbus protocols.....	18
6.2. Digital variables.....	18
6.3. Analogue variables.....	23
6.4. Integer variables.....	28
7. Variables de supervisión Ionworks®.....	34

Connection of units with CIATrtc control to a local communications network (pLAN)

1. TECHNICAL CHARACTERISTICS OF A pLAN

Units with an **CIATrtc** control can be connected with the pLAN (μ PC MEDIUM Local Area Network), enabling the communication of data and information from one location (node) to another. This network connection also enables the number of PGD1 terminals to be reduced, since a single common terminal can monitor all of the μ PC MEDIUM boards.

The following figure shows the connection scheme for this network, which permits a maximum of 15 units.

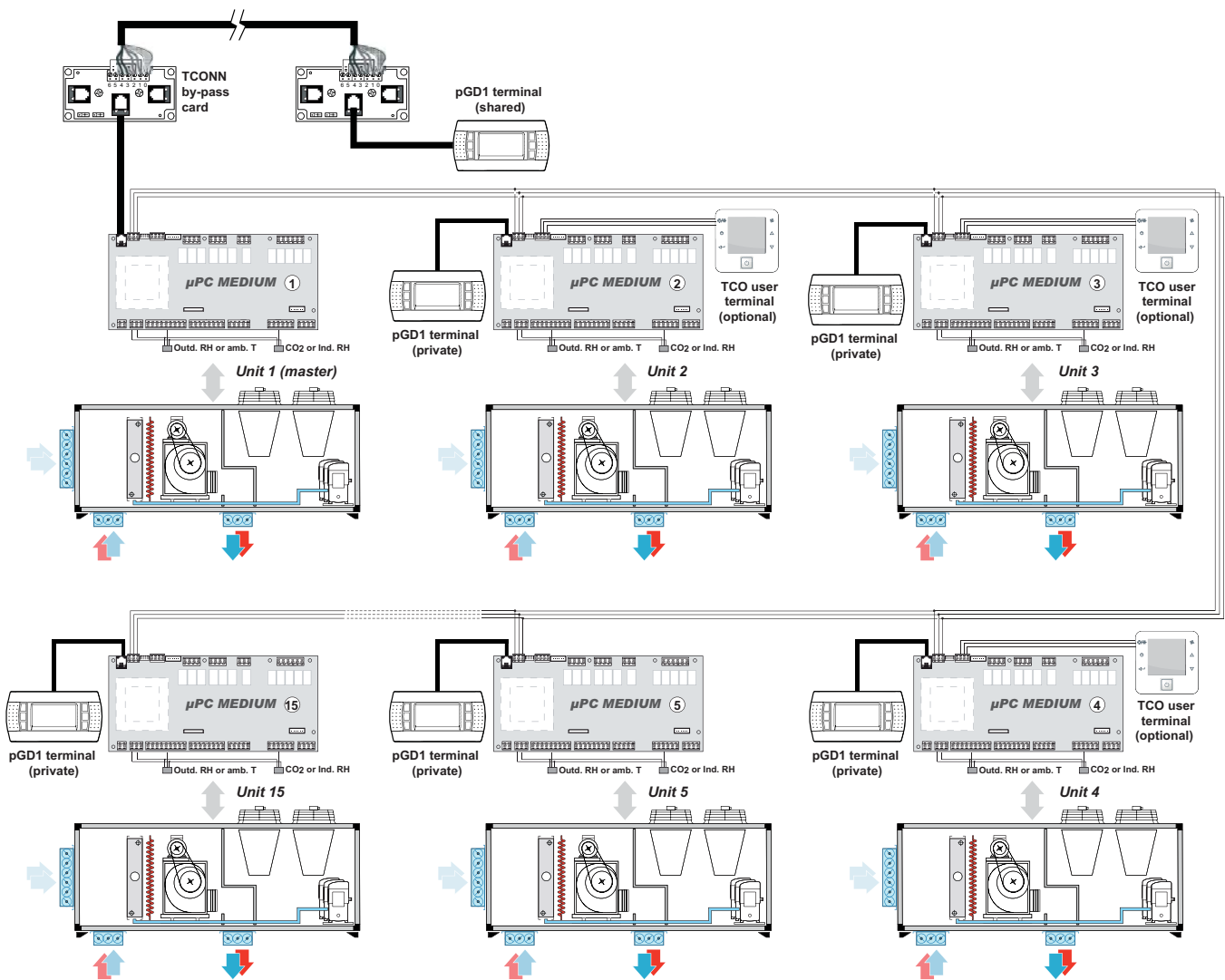

The following technical characteristics of the pLAN are emphasized:

- Communications standard: RS485.
- Transmission speed in baud: 65,2 Kbit/s.
- Protocol: Multimaster (property of CAREL).
- Maximum network length: 500 metres.

2. COMPONENTS OF THE pLAN

2.1. Minimal configuration

A pLAN must be formed, at minimum, by the following components:

- A **μPC MEDIUM board** for each of the units that are going to be integrated into the network. The maximum number of units which could form part of the aforementioned network will be 15. One of the units will be configured as the master unit in the network and the rest as slaves.
- A **pGD1 terminal** which will be configured as a common terminal. All of the boards integrated into the network can be monitored from this terminal.

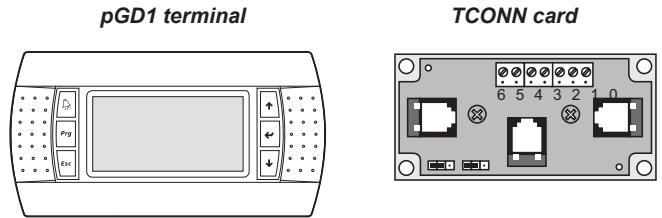

2.2. Additional elements

- **Private pGD1 terminals**, as many controllers can be added as there are units in the network.
- **TCONN bypass cards** required for the remote installation of a pGD1 terminal at distances greater than 50 metres.
- **Shared probes**: If the facility's conditions permit it, the readings from some probes installed in the master unit can be shared by all network units.

These probes are:

- **Outdoor temperature** (analogue input B2):
This probe is standard but can be shared, for example, in case of failure of this probe in some unit of the pLAN network.
- **Outdoor humidity** (analogue input B5):
This probe is used instead of the one for the outdoor temperature and is used with the optional of enthalpic or thermoenthalpic free-cooling.
If the unit needs this humidity probe, the NTC ambient temperature probe can't be installed on the board. In this case it is necessary to use a RS485 ambient temperature probe connected on the Field-bus.
Up to four ambient probes can be connected on the Field-bus of the μPC MEDIUM board using RS485 serial cards, configured with different addresses (see attached drawing).
- **Ambient temperature** (analogue input B5 or field-bus RS485):
If the unit needs the outdoor humidity probe (with enthalpic or thermoenthalpic free-cooling), the NTC ambient temperature probe can't be installed on the board. In this case it is necessary to use a RS485 ambient temperature probe connected on the Field-bus.
Note: An ambient probe with RS485 communication is required for installation to more than 30 metres.
- **CO₂ air quality** (analogue input B10):
Optional for the free-cooling option the control can add a probe for measuring the CO₂ and/or volatile compounds.
- **Indoor humidity** (analogue input B10 or field-bus RS485):
This probe is required with enthalpic free-cooling and / or for the regulation of humidity.

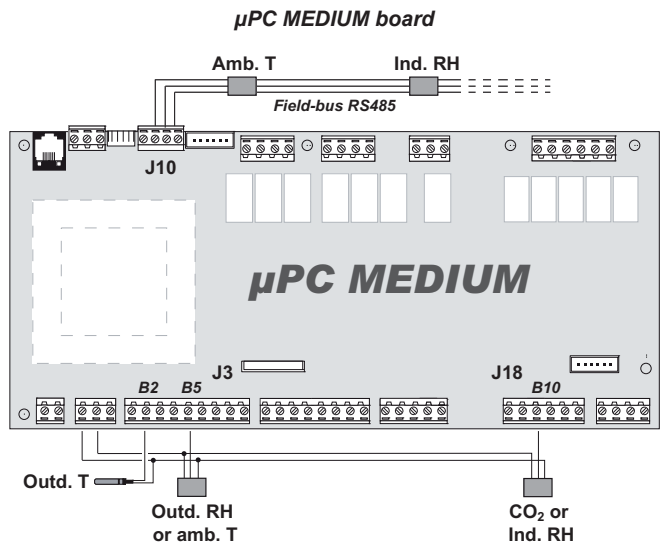

Conection of RS485 ambient probes

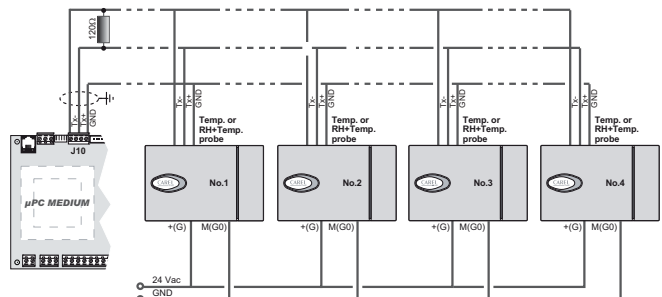

RS485 probe configuration:

Ambient probe No.1:	Ambient probe No.2:	Ambient probe No.3:	Ambient probe No.4:
Address: 128	Address: 129	Address: 130	Address: 131
Modbus 1, 8, N, 2	Modbus 1, 8, N, 2	Modbus 1, 8, N, 2	Modbus 1, 8, N, 2
9600 bps	9600 bps	9600 bps	9600 bps
ON	ON	ON	ON
1 2 3 4 5 6 7 8	1 2 3 4 5 6 7 8	1 2 3 4 5 6 7 8	1 2 3 4 5 6 7 8

Important: It is recommended to insert an electrical resistance of 120Ω, between connectors TX+ and TX- of the μPC MEDIUM output (connector J10) and on the final component of the RS485 network, to avoid potential problems of communication.

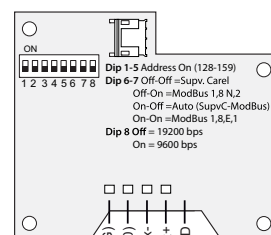

3. CONNECTION OF THE pLAN

3.1. Connection of the μ PC MEDIUM boards

The interconnection of the boards is done in parallel using their **J11 connectors** ensuring network polarity: the RX/TX+ of a board must be connected to the RX/TX+ of the other boards; the same is applicable to the RX/TX-.

The electrical connections in the pLAN are made by using an AWG 20/22 shielded cable with a braided pair plus shield.

Important: before interconnecting the boards, it is necessary to assign them an address (See Chapter 4: configuration of the pLAN).

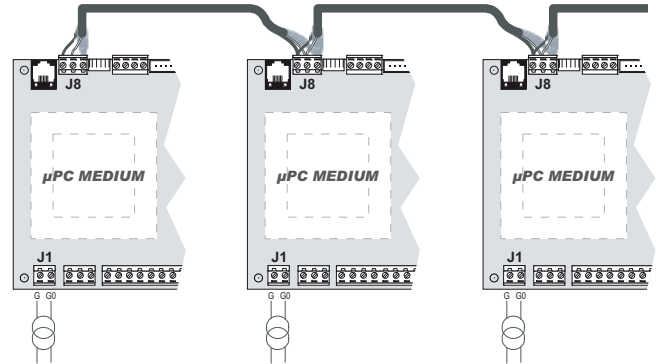

3.2. Connection of the pGD1 terminals

Installation of the terminal at less than 50 metres

If the terminal is placed at a distance less than 50 metres, the connection is done with a 6-wire telephone cable.

Recommendations:

- The telephone cable has to be perpendicular to the board.
- Separate the telephone cable from the power lines to avoid electromagnetic interference.
- If deemed necessary, insert two magnets into the telephone cable, one on the side of the terminal and the other on the side of the μ PC board (in the areas marked with the letter F in the attached drawing).

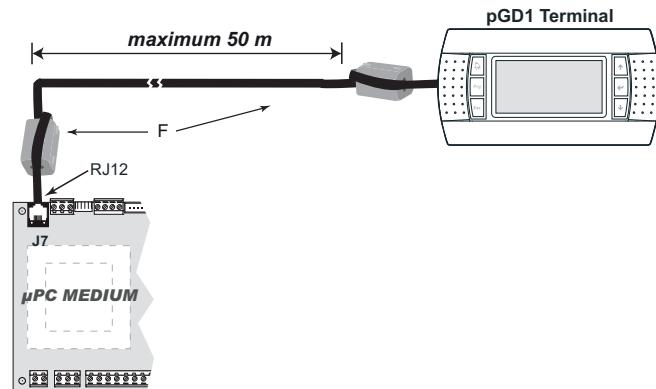

Installation of the terminal at less than 200 metres

Two TCONN bypass cards are necessary for this type of installation. They are connected by using AWG 20/22 shielded cable with two braided pairs plus a shield (4-wire).

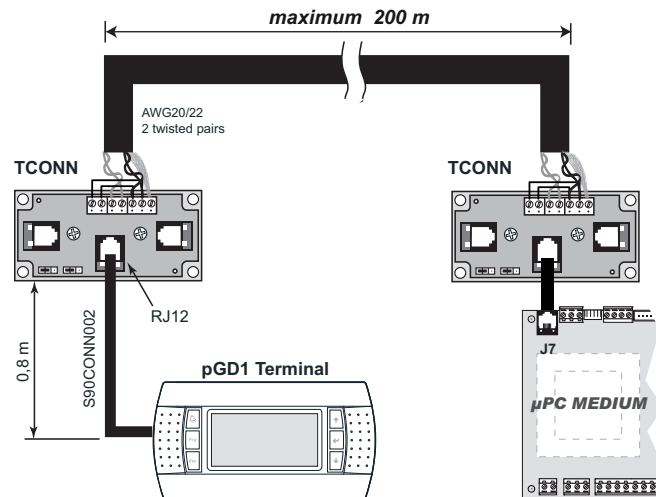

AWG 20/22 cable (with power supply)		
terminal	cable function	connections
0	ground	display
1	+VRL (H30 Vdc)	1 st pair A
2	gnd	2 nd pair A
3	Rx/Tx -	1 st pair B
4	Rx/Tx -	2 nd pair B
5	gnd	--
6	+VRL (H30 Vdc)	--

Installation of the terminal at up to 500 metres

Two TCONN bypass cards and a power supply for powering the terminal are needed for this type of installation. For the connection of the bypass cards AWG 20/22 shielded cable is used. The connection is established using one braided pair plus a shield (2-wire).

Note: Position J-14 and J-15 in 2-3. Otherwise, the transformer can be short-circuited. The pGD1 terminal must be connected to the left side of the TCONN card on the connector located above J-14 and J-15.

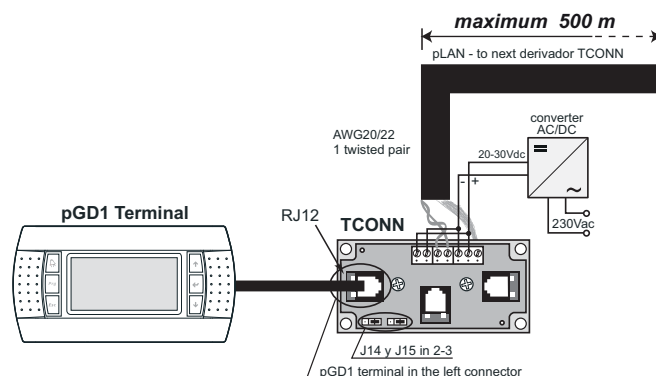

4. CONFIGURATION OF THE pLAN

A pLAN shall be made up of a maximum of:



- 15 µPC MEDIUM boards: addresses 1 to 15. Address 1 shall be reserved for the master board.
- 1 common terminal: address 16.
- 15 private terminals: addresses 17 to 31. The address of each private terminal will coincide with the address total for the corresponding board + 16.

The steps necessary for completely configuring the pLAN are described in the following displays.

Note: both the units and the terminals are pre-configured in the factory.

4.1. Addressing of the µPC MEDIUM boards

Note: To assign addresses to the pLAN boards, they **cannot** be connected to that network.



- The procedure is activated by simultaneously pressing the UP  + DOWN  + ENTER  keys.
- It is first of all necessary to configure the terminal with address 00 on the following display:

```

Display address
setting:      16
I/O board
address:     02
    
```

Display address setting: this represents the address of the terminal on which you are working.

To change this address, press the ENTER  key until the cursor is above the terminal's address.

Change the address value with the UP  and DOWN  keys until 00 appears. Press the ENTER  key to confirm the value.

```

Display address
changed
    
```

When the 00 address has been set, **Display address setting** (address of the modified terminal) appears on the display.

This operation is only performed once and serves to configure all of the µPC MEDIUM boards.

Afterwards, proceed as follows for each of the pC03 boards:

- Cut the electricity supply.
- Next, simultaneously press the ALARM  + UP  keys for a few seconds and turn the board on.

Once this operation is done, the following displays will appear:

```

#####
Selftest
Please wait
#####
    
```



```

pLAN address
up:      increase
down:    decrease
enter:   save &exit
    
```

- When all the boards have been assigned their address they can be reconnected to the network using the J11 connector for each board to do so.

4.2. Configuration of the common terminal





All of the µPC MEDIUM boards that make up the network can also be monitored from a single terminal, known as the common terminal. **This operation only has to be performed once, with a terminal that is connected to any unit.**

- To start the procedure, it is necessary to supply power to the unit to which the terminal has been connected.
- By simultaneously pressing the UP  + DOWN  + ENTER  keys, the following display appears:

```
Display addresss
setting:      00
```

This display indicates that the control currently has the address 00. This is used to guide the µPC MEDIUM boards, as explained in the previous section.

```
Display addresss
setting:      16
I/O board
address:      --
```

To change this address, press the ENTER  key, and the cursor will be above the terminal's address. Change the address value with the UP  and DOWN  keys until 16 appears. The I/O board address (address of the board) appears at the same time with the value "--". Press the ENTER  key to confirm the value 16.

```
Display addresss
changed
```

If the procedure has been performed correctly, Display address setting (address of the modified terminal) appears on the display.

```
NO LINK
```

If NO LINK (no communication) appears instead of the previous display, power is cut, restarted, and the entire procedure is repeated.

4.3. Assignment of the terminals for each µPC MEDIUM board

Next, the addresses will be assigned to each of the boards which make up the network as they correspond to the common terminal and for their private terminal (even if they do not have one at that time). The address for the private terminal must coincide with the sum of the corresponding board + 16.

- By simultaneously pressing the UP  + DOWN  + ENTER  keys, the following display appears:

```
Display addresss
setting:      16
I/O board
address:      XX
```

This display represents:
 Display address setting = 16: address of the common terminal.
 I/O board address = XX: address of the board in which the terminal is connected (values 1 to 15).
 The values for this display are confirmed by pressing the ENTER  key 3 times.

```
Terminal config
press ENTER
to continue
```

From this display, pressing the ENTER  key grants access to the display in which the addresses of the private and common terminals are assigned for the board with address XX.

```
P:XX adr Priv/shared
trm1 16          sh
trm2 YY          Pr
trm3 none        OK?
```

Pressing the ENTER  key on this display moves the cursor from one field to another, while the cursor keys change the current value of the field. The text "P:XX" indicates that, in this case, the I/O board with address XX has been selected.

trm1=16 (terminal 1: address 16) → shared (to switch between the different control boards)

trm2=YY (terminal 2: address YY) → private (only for displaying the board output with address XX).

As shown above: YY = XX + 16. For example:

- a private terminal with address 17 will correspond to the board with address 01, i.e., 17 = 01 + 16
- a private terminal with address 18 will correspond to the board with address 02, i.e., 18 = 02 + 16

To exit the configuration procedure and save, select the 'OK ? NO' field, place the cursor over the 'YES' text and then press ENTER .



To exit without saving, leave the terminal alone without touching any key for 30 seconds.

When the terminal is connected to the above board, the addresses of the terminals can be assigned for the rest of the boards without needing to change the unit.

To do so, simultaneously press the UP  + DOWN  + ENTER  keys, and the following display appears:

```
Display addresss
setting:      16
I/O board
address:      XX
```



By pressing the ENTER  key, the address of the common terminal is confirmed in "Display address setting".

In the I/O board address section, with the help of the UP  and DOWN  keys, we change the following board from the network to which its terminals are going to be assigned. By pressing the ENTER  key, this display is shown:

```
Terminal config
press ENTER
to continue
```



From this point, repeat the above steps to assign addresses.

When the network is completely configured from the common control and in place for each board, the rest of the network boards can be supervised.

To move from one board to another, press the ESC  +DOWN  keys.

For example, the following display is the main one for the board with address 1 (Unit: 01):

```
P01
Unit: 01 00:00 WIN
Indoor T:    00.0°C
Outdoor T:   00.0°C
Indoor RH:   00.0%
Unit On
```

By pressing the ESC  +DOWN  keys, it goes to the main display of the board with address 2.

4.4. Configuration of independent units

All of the units with the CIATrtc electronic control are pre-configured in the factory as a pLAN, although this network is only formed by a board and a terminal.

In this case, the address 01 (master) will be assigned to the board and the address 16 (common) is assigned to the terminal.

In the special case of a single unit with two pGD1 terminals, one placed above the unit and another at a distance. The first is pre-configured in the factory as a common control with address 16 and the second is configured as a private control with address 17.

Note: Terminals supplied separately are not addressed. This operation is performed on the job.

4.5. Configuration of the common probes (optional)

Probes installed on the unit which is configured as master can be shared on the network (if the facility's conditions permit such): outdoor temperature, outdoor humidity, indoor humidity, ambient temperature and CO₂ air quality probe.

All of the units will read from these probes, except those which have incorporated their own probes (physically configured).

From any display on the CIATrtrc control, pressing the PRG + ESC keys at the same time for a few seconds grants access to the start display of the TECHNICAL MENU:

```

Technical Menu
User          :
Maintenance   :
MANUFACTURER : →
    
```

Select MANUFACTURER with the ENTER key. Press the ENTER key again to confirm.

The MANUFACTURER group of displays is protected by an access key. If the password has to be known: consult.

Once the password has been entered, the following display is accessed:

```

MANUFACTURER MENU
Unit Configuration
Defrosting Config.
Compressor Config.
Control Config.
Safety Config.
Alarm Config
Unit Initializ.
    
```

Select UNIT CONFIGURATION and press the ENTER key to confirm.

Move through this group of displays with the UP and DOWN keys until arriving at the following display:

```

CU09
Ambient Probe: YES
Control by ambient T.

Amb. Probe type: pLAN
    
```

There are different options for the ambient probe:

- NTC (by default): one ambient probe installed on the analogue input B5 (if the unit does not incorporate outdoor humidity probe). The maximum distance of the NTC sensor to the control board can be 30 metres.
- 4-20mA: one ambient probe installed on the analogue input B5 (if the unit does not incorporate outdoor humidity probe).
- RS485: one to four ambient probes connected to the Field-bus on the µPC MEDIUM board using RS485 serial communication card(s).
- pLAN: one ambient probe installed on the master unit of a pLAN network.

```

CU10
Outlet Probe      Y
Outd.T. Probe     pLAN
Ind. RH probe     pLAN
Outd.RH probe     pLAN
Outd.unit sens.   Y
Ind.unit sens.    Y
    
```

Outd. T. Probe: No, actual, pLAN. By default: actual, but there can use the reading of the probe of the master unit in case of breakdown of this probe in some unit of the network pLAN.

Ind.HR Probe: No, actual, virtual, pLAN, RS485. This probe is necessary for enthalpic free-cooling and/or humidity control. The installation of this probe in the field-bus RS485 allows the installation of air quality probe in the analogue input B10 (see CU11).

Probe HR. ext: No, actual, pLAN. This probe is necessary for enthalpic free-cooling.

```

CU11
Probe for refresh.:
  pLAN Air quality
Activate control:  Y
Units:ppm?
Mixing temp. probe: Y
    
```

Probe para renov: The probe type for controlling the inlet of air from the outdoor damper (units with mixing boxes) can be selected on this display. There are 3 options:

- Mixed air temperature probe (NTC type).
- Actual air quality probe (4-20mA type): in this case, on the display, it is mandatory to select that the mixing probe is installed in the analogue input B10. If the unit incorporates the probe of indoor humidity (ambient or duct), this will be connected to the RS485 field-bus (selected on CU10). The installation of mixed probe + air quality probe improves the management of the air refreshing with low outdoor temperatures.
- pLAN air quality probe (4-20mA type): if the unit is included in a pLAN network can use the reading of the probe of air quality installed physically in the unit No.1.

To move from one board to another, press the Esc and Down keys from the control display.

5. MONITORING OF THE pLAN

5.1. Viewing the terminal's connection status

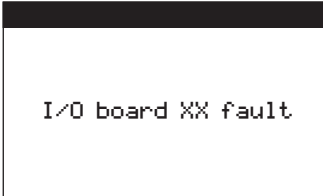

If the terminal shows a state of inactivity for the μ PC MEDIUM CPU board on which outputs are to be seen, the display completely shuts off and the following message appears:



If the terminal does not receive the network synchronisation message (token) for more than 10 seconds, the display completely shuts off and this message appears. This is equivalent to the green stopped LED condition for the I/O board.

5.2. Network status view

There is a procedure in the program known as **NETSTAT**, which enables the status to be viewed in real time and the type of peripherals connected at that time.

This procedure is activated by simultaneously pressing the UP + DOWN + ENTER keys for at least 10 seconds.

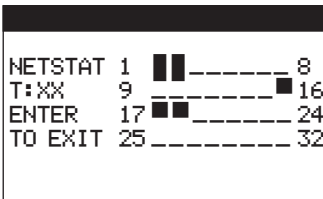

The number after T: This indicates the terminal address from which the procedure is being activated, the symbol indicates the type of peripheral: μ PC MEDIUM board (■) or terminal (■), as well as the respective address.

In the example, the network is composed of 2 μ PC MEDIUM boards with addresses 1 and 2 (address 1 will correspond to the master) and of 3 terminals with addresses 16, 17 and 18 (16 will correspond to the common terminal).

The start display of the MAIN MENU is accessed from any display of the CIATrtc control by pressing the PRG key:

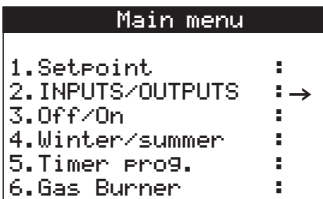

Select INPUTS/OUTPUTS and press the ENTER key to confirm.

Move through this group of displays with the UP and DOWN keys until arriving at the I13 display .

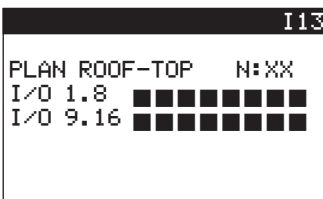

This display shows the number of μ PC MEDIUM boards that are connected to the pLAN, as well as the position they occupy, in accordance with the criteria set forth above for assigning addresses. No. 16 is reserved for the common terminal.

N:XX Identification number of the unit from which the connection is being performed.

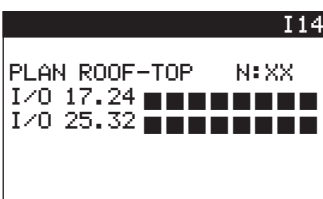

This display shows the number of private terminals that are connected to the pLAN, as well as the position they occupy. The address of each terminal must coincide with the board to which it is associated +16.

Connection of units with CIATrtc control to a Supervisory System (BMS)

1. COMMUNICATION PROTOCOLS

The CIATrtc electronic control is programmed to allow communication to be established with a centralised management system, making use of a BMS card for some of the following communications protocols.

Carel y Modbus

One RS485 serial card is connected to each μ PC MEDIUM board for the supervisory network with both the Carel protocol and the Modbus protocol. This network enables a data transmission rate of 19200 bps.

Note: the supervisory variables for integration into the supervisory system are found at the end of this brochure.

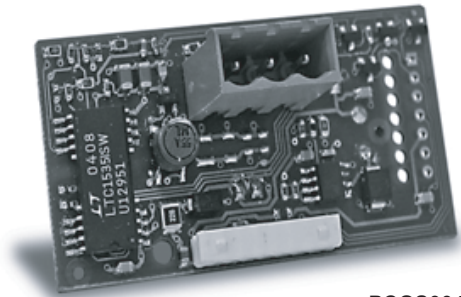

PCOS004850

LonWorks®

To establish communication with a network with the LonWorks® protocol, each μ PC MEDIUM board needs a FTT-10A 78kbs (TP/FT-10) serial card. This network enables a data transmission rate of 4800 bps.

The supervisory program is stored in flash memory and can be programmed directly from the LonWorks® network by using tools such as LonMaker®.

Note: the supervisory variables for integration into the client's LonWorks® supervisory system are found at the end of this brochure.

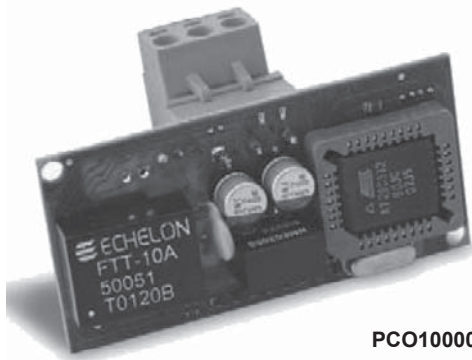

PCO1000F0

BACnet™

To establish communication with a network with the BACnet™ MSTP protocol, each μ PC MEDIUM board needs a BACnet™ RS485 serial card. This open standard, developed by ASHRAE, enables air conditioning and heating systems for homes and buildings to be connected for the sole purpose of performing intelligent energy management.

Configuration by the integrator.



PCO1000BAO

Konnex (KNX)

To establish communication with a network with the Konnex protocol, each μ PC MEDIUM board needs a Konnex serial card. This open standard enables the connection and integration of devices in building automation applications both at the commercial and at the residential level, with a data transfer speed of 9600 bps.

Configuration by the integrator.

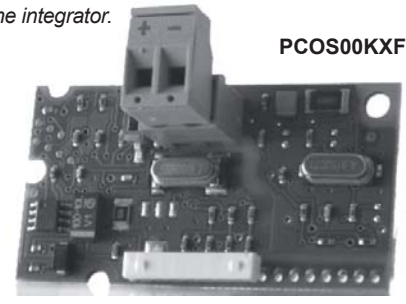

PCOS00KXF0

Ethernet pCO Web

The Ethernet pCO Web card allows the network communication with the protocols Modbus TCP/IP, BACnet™ Ethernet, TCP/IP, SNMP V1-2-3, FTP y HTTP.

BACnet™ Ethernet: *Configuration by the integrator.*

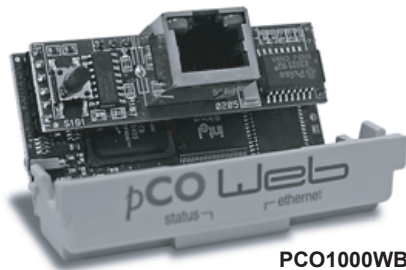

PCO1000WB0

2. SUPERVISION SOLUTIONS

Different solutions of supervision are available according to the dimensions of the installation.

pCO Web

It is the solution for the management and supervision of a single unit if it incorporates the Ethernet pCO Web card.

PlantWatchPRO3

It is a solution designed for the monitoring of installations of medium - small dimensions, with ability to manage up to 30 units. Suitable for technical environments, it has no parts in movement. It's available in two versions: panel and wall.

Includes: 7 " touch display, buzzer for notifications, 1 USB port and 1 SD card slot for downloading reports, charge devices models and applying service packs.

In this case, each unit needs one RS485 Carel / Modbus board.

PlantVisorPRO2

This is the solution for the management and supervision of air-conditioning installations with up to 300 units. It performs advanced monitoring and maintenance functions and enables creating areas and groups which simplify the management of the installation. It also allows the integration of energy meters for monitoring the power consumption of the installation.

PlantVisorPRO2 is available in two versions:

- **Box:** comprised of the CPU unit and, optionally, by monitor and keyboard.
- **Touch:** this includes the CPU and the touchscreen in the one device.

In this case, each unit needs one RS485 Carel / Modbus board.

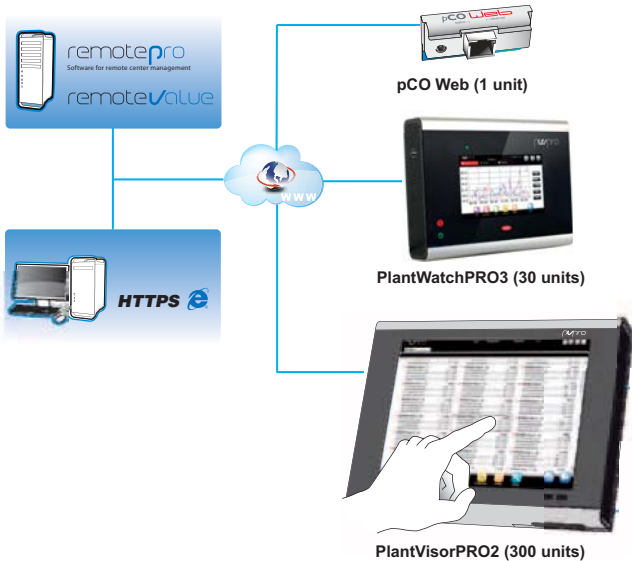

These systems allow the installation in remote management. Through a single connection to the Internet is accessed the information system. The Web interface, which is available for the local user, allows the monitoring and the complete configuration of the installation: from the office or any other user's current location.

For remote control of multiple sites, there are dedicated tools for centralized management as **RemotePRO** and **RemoteValue**.

3. RS485 SUPERVISORY NETWORK

An RS485 supervisory network with the Carel or Modbus protocol must be made up of, at minimum, the following components:

- A μ PC MEDIUM board for each of the units (maximum 207 units) that are going to be integrated into the network.
- One RS485 serial card for each of the μ PC MEDIUM boards.
- One pGD1 terminal which will be shared by all the boards which are in the network, even if controllers or units can be added to make up the network.
- TCONN bypass cards for each pGD1 terminal which is installed further than 50 metres from the unit.
- A CIAT supervisory solution (Carel protocol) or a management software installed on a PC (Modbus Protocol).

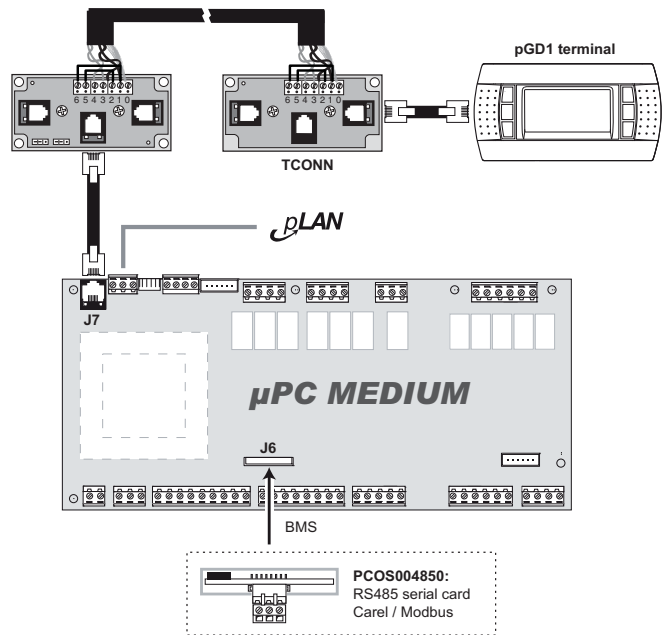

Recommendations for the connection:

- The interconnection of the RS485 boards is done in parallel, from the connector J6 of a board to the connector J6 of the following one, ensuring network polarity: the "+" connector of a board must be connected to the "+" connector of the other boards; the same applies to the "-".
- In accordance with the electromagnetic compatibility standard, it is recommended to use cables made for transmitting RS485 data.
- In case there are problems in detecting all of the elements present, insert a electrical heater of 120 Ω , between connectors "+" and "-".

Note: In addition to integrating the units into the supervisory network, the pLAN can also be connected and configured (described previously in this brochure). For this type of installation, it is recommended to assign the same address to the units on both networks to facilitate their identification.

4. ETHERNET SUPERVISORY NETWORK

In order to establish the Modbus TC/IP communication a pCO web card must be installed on the μ PC MEDIUM board instead of the RS485 card. This card can also be used for communication with a network with BACnet™ Ethernet™, SNMP V1-2-3, FTP or HTTP protocols.

In the Modbus TCP/IP communication the following must be taken into account:

- The control must be configured as CAREL protocol, address 1 and baud rate of 19200.

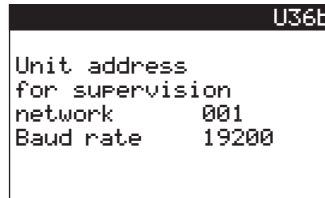
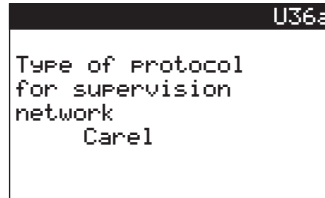
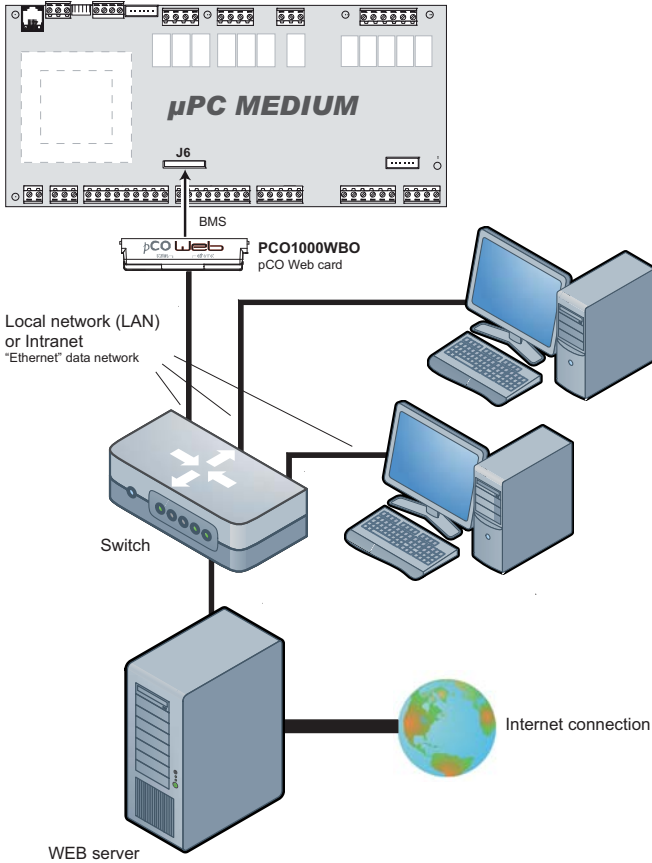

- The TCP port used is 502 (this cannot be modified).
- The IP address must be configured with a fixed value.
- The addresses of the supervisory variables are as follows:
 - Digital variables: 1 to 207
 - Analogue variables: 1 to 207
 - Integer variables: 5001 to 5207
- The commands supported by pCO web with modbus TCP/IP are:
 - 01: Digital variable reading
 - 03: Integer or analogue variable reading
 - 05: Simple writing of digital variables
 - 06: Simple writing of integer or analogue variables
 - 15: Multiple writing of digital variables
 - 16: Multiple writing of integer or analogue variables



The pCO Web card includes 2 LEDs to indicate the status of the card and of the Ethernet communication.

Note: if more detailed information is required on the connection of the pCO Web card please request the installation brochure.

5. CONFIGURATION OF THE SUPERVISORY NETWORK

5.1. Enabling of the supervisory network

From any display on the CIATrtc control, pressing the PRG  + ESC  keys at the same time for a few seconds grants access the start display of the TECHNICAL MENU:

Technical Menu	
User	:
Maintenance	:
MANUFACTURER	: →



Select MANUFACTURER with the ENTER  key. Press the ENTER  key again to confirm.

The MANUFACTURER group of displays is protected by an access key. If the password has to be known: consult.

Once the password has been entered, the following display is accessed:

MANUFACTURER MENU	
Unit Configuration	
Defrosting Config.	
Compressor Config.	
Control Config.	
Safety Config.	
Alarm Config	
Unit Initializ.	

Select UNIT CONFIGURATION and press the ENTER  key to confirm.

Move through this group of displays with the UP  and DOWN  keys until arriving at the following display:

CU14	
Supervision	N
Summer fcooling	Y
Winter fheating	N
Winter fcooling	Y
Air refreshing	Y
100% outdoor air	N

Supervision: this authorises the connection of the unit to a supervisory network for centralised technical management (Carel, Modbus or Lonworks® protocols).

5.2. Selection of the supervisory type

From any display on the CIATrtc control, pressing the PRG  + ESC  keys at the same time for a few seconds grants access the start display of the TECHNICAL MENU:

Technical Menu	
USER	: →
Maintenance	:
Manufacturer	:

Select USER with the ENTER  key. Press the ENTER  key again to confirm.

The group of USER displays is protected by an access key. If the password has to be known: consult.

Once the password has been entered, it is possible to access the other displays by pressing the  key.

U36a	
Type of protocol for supervision network	
Carel	

This display is for selecting the protocol type to be used in an installation with centralised technical management.

The available protocols with CIATrtc are: Carel, Lonworks® and Modbus.

Note: "commissioning" can also be selected to display the variables using the PCO MANAGER software.

5.3. Addressing of the µPC MEDIUM boards on the supervisory network

From any display on the CIATrtrc control, pressing the PRG  + ESC  keys at the same time for a few seconds grants access the start display of the TECHNICAL MENU:

```

Technical Menu
USER          : →
Maintenance   :
Manufacturer   :
    
```

```

User Menu
Control       :
COMMUNICATION : →
Other         :
    
```

```

U36b
Unit address
for supervision
network      001
Baud rate    19200
    
```

Select USER with the ENTER  key. Press the ENTER  key again to confirm.

The group of USER displays is protected by an access key. If the password has to be known: consult.

Once the password has been entered, it is possible to access the other displays by pressing the  key.

The USER displays are divided into three groups to which access is possible from this display. MPC MEDIUM boards are addressed within the COMMUNICATION group.

Unit address: address for centralised control.

Baud rate: transmission speed (bit rate) in bps: 19200 (with standard modem), 9600, 4800 (with Lonworks protocol), 2400, 1200.

With Modbus protocol this display also will show the following parameters:

Stop bit No: this variable can take value 1 or 2.

Parity type: without parity, couple or odd.

Configuration depending on the installed communications card:

RS485 serial card

Protocol: CAREL or MODBUS

Address: 1 to 207

Baud rate: 1200, 2400, 4800, 9600, 19200 bps

LONWORKS FTT serial card

Protocol: LON

Address: 1 (the address is configured in the communication card)

Baud rate: 4800 bps

KONNEX serial card *(Configuration by the System Integrator)*

Protocol: MODBUS

Address: 1 (the address is configured in the communication card)

Baud rate: 9600 bps

BACNET MSTP RS485 card *(Configuration by the System Integrator)*

Protocol: CAREL o MODBUS

Address: 1 to 207

Baud rate: 1200, 2400, 4800, 9600, 19200 bps

ETHERNET PCOWEB card

Protocol: CAREL

Address: 1 (the address is configured in the communication card)

Baud rate: 19200 bps

BACNET ETHERNET PCOWEB card *(Configuration by the System Integrator)*

Protocol: CAREL

Address: 1 (the address is configured in the communication card)

Baud rate: 19200 bps

6. CAREL AND MODBUS SUPERVISORY VARIABLES

6.1. Equivalence between the Carel and Modbus protocols

Carel		Modbus			TCP/IP Modbus	
Variable type	Maximum No. addresses	Type of variable	Maximum No. addresses	Conversion	Maximum No. addresses	Conversion
Digital	1 ... 207	Digital	1 ... 207	Modbus record = Carel address	1 ... 207	TCP/IP address = Carel address
Analogue	1 ... 207	Word record	1 ... 207	Modbus record = Carel address	1 ... 207	TCP/IP address = Carel address
Integer	1 ... 207	Word record	208 ... 415	Modbus record = Carel address +128	5001 ... 5207	TCP/IP address = Carel address +5000

Note: Carel peripherals do not allow the 0 address.

6.2. Digital variables

Carel Address	Modbus record	Modbus extended	Read / Write	Variable	Parameter type	Min. value	Max. value	Description
1	1	1	R	IN_DIG13_AP1	Digital input	0	1	HP pressure switch circuit 1
2	2	2	R	IN_DIG14_AP2	Digital input	0	1	HP pressure switch circuit 2
3	3	3	R	IN_DIG7_BP1	Digital input	0	1	LP pressure switch circuit 1
4	4	4	R	IN_DIG9_BP2	Digital input	0	1	LP pressure switch circuit 2
5	5	5	R	IN_DIG8_TC1	Digital input	0	1	Thermal compressor 1 of circuit 1
6	6	6	R	IN_DIG10_TC2	Digital input	0	1	Thermal compressor 1 of circuit 2 (units 2 circ.) or compressor 3 (units 4 circ.)
7	7	7	R	IN_DIG6_TS	Digital input	0	1	Electrical heater(s) thermal protection
8	8	8	R	IN_DIG5_ON_OFF	Digital input	0	1	Remote ON/OFF selection
9	9	9	R	IN_DIG3_C_F	Digital input	0	1	Remote HEATING/COOLING mode selection
10	10	10	R	IN_DIG1_AH_BAC	Digital input	0	1	Anti-freeze thermostat signal
11	11	11	R	IN_DIG2_FS	Digital input	0	1	Clogged filter pressure switch signal
12	12	12	R	IN_DIG4_RTVI	Digital input	0	1	Indoor fan overload/general interlock signal (RTVi)
13	13	13	R	MODO_CALOR	Status	0	1	HEATING (winter) operating mode
14	14	14	R	MODO_FRIO	Status	0	1	COOLING (summer) operating mode
15	15	15	R	Fan_INT	Digital output	0	1	Indoor fan
16	16	16	R	Compressor_1	Digital output	0	1	Switch of compressor 1 of circuit 1
17	17	17	R	Compressor_2	Digital output	0	1	Switch of compressor 1 of circuit 2 (units 2 circ.) or compressor 3 (units 4 circ.)
18	18	18	R	OUT_VIC1	Digital output	0	1	Cycle reversing valve circuit 1
19	19	19	R	OUT_VIC2	Digital output	0	1	Cycle reversing valve circuit 2
20	20	20	R	RES_ELECTRICA_1_O_BAC	Digital output	0	1	Switch of the 1st heater or burner stage
21	21	21	R	RES_ELECTRICA_2	Digital output	0	1	Switch of the 2nd heater or burner stage
22	22	22	R	HUMIDIFICA	Digital output	0	1	Outlet for the humidifier
23	23	23	R	Fan_EXT_1	Digital output	0	1	Low-speed outdoor fan circ. 1 (units 1 or 2 circ.) / low-speed outdoor fan circ. 1 & 2 (units 4 circ.)
24	24	24	R	Fan_EXT_2	Digital output	0	1	Low-speed outdoor fan circ. 2 (units 2 circ.) / high-speed outdoor fan circ. 1 & 2 (units 4 circ.)
25	25	25	R/W OEM	RESET_ALARMS	Alarm	0	1	Alarm reset
26	26	26	R	GLOBAL_ALARM	Alarm	0	1	General alarm
27	27	27	R	mAL_TERM_COMP_VEXT_1	Alarm	0	1	Alarm for thermal compressor 1 circuit 1
28	28	28	R	mAL_TERM_COMP_VEXT_2	Alarm	0	1	Alarm for thermal compressor 1 circuit 2 (units 2 circ.) or compressor 3 (units 4 circ.)
29	29	29	R	mAL_AP1	Alarm	0	1	Alarm due to high pressure of circuit 1
30	30	30	R	mAL_AP2	Alarm	0	1	Alarm due to high pressure of circuit 2
31	31	31	R	mAL_ANTIHILO_BAC	Alarm	0	1	Anti-freeze alarm



Communications electronic control

Carel Addr.	Modbus record	Modbus extended	Read / Write	Variable	Parameter type	Min. value	Max. value	Description
32	32	32	R	mPERM_MEM_ERROR	Alarm	0	1	Damaged EPROM
33	33	33	R	mAL_RELOJ	Alarm	0	1	Timer broken or disconnected
34	34	34	R	mAL_ALT_TEMP_REG	Alarm	0	1	Overly high return air temperature
35	35	35	R	mAL_BAJ_TEMP_REG	Alarm	0	1	Overly low return air temperature
36	36	36	R	mAL_SET_HOR_COMP1	Alarm	0	1	Maintenance of compressor 1 of circuit 1
37	37	37	R	mAL_SET_HOR_COMP2	Alarm	0	1	Maintenance of compressor 1 of circuit 2 (units 2 circ.) or compressor 3 (units 4 circ.)
38	38	38	R	mAL_BP1	Alarm	0	1	Alarm due to low pressure of circuit 1
39	39	39	R	mAL_BP2	Alarm	0	1	Alarm due to low pressure of circuit 2
40	40	40	R	mAL_TERM_VENT_INT	Alarm	0	1	General interlock alarm (RTVi)
41	41	41	R	mAL_T_P_BEXT_C1	Alarm	0	1	Outdoor coil sensor of circuit 1 alarm
42	42	42	R	mAL_T_P_BEXT_C2	Alarm	0	1	Outdoor coil sensor of circuit 2 alarm
43	43	43	R	mAL_FILTRO_SUCIO	Alarm	0	1	Clogged filter alarm
44	44	44	R	mAL_TERM_RES_ELECTRICA	Alarm	0	1	Electrical heater(s) thermal protection alarm
45	45	45	R/W OEM	HAB_BOMBA_CALOR	Configuration	0: cooling only 1: heat pump		Enable operation in heat pump mode
46	46	46	R	HAB_RELOJ	Status	0: no; 1: yes		Enable timer board
47	47	47	R/W OEM	HAB_CONTROL_HUM_DESHUM	Configuration	0: no; 1: yes		Enable dehumidification function
48	48	48	R/W OEM	HAB_Probe_TEMP_IMP	Configuration	0: no; 1: yes		Enable discharge sensor
49	49	49	R	SEL_FC_FH_ENTALPICO	Status	0: no; 1: yes		Enable enthalpic free-cooling
50	50	50	R/W OEM	HAB_SUPERVISION	Configuration	0: no; 1: yes		Enable the supervisory serial board
51	51	51	R	MOD_MB_VFD_C1AT_1. mAL_Offline_VFD	Alarm	0	1	Communication fault with the frequency inverter of indoor motor
52	52	52	R/W OEM	HAB_FREECOOL	Configuration	0: no; 1: yes		Enable free-cooling in COOLING mode (summer)
53	53	53	R/W OEM	HAB_FREEHEAT	Configuration	0: no; 1: yes		Enable free-heating in HEATING mode (winter)
54	54	54	R/W	POS_COMPUERTA_CALOR_AL_INICIO	Regulation	0: normal 1: closed		Select outdoor air damper position at start-up in HEATING mode
55	55	55	R/W OEM	HAB_COMPENSACION	Configuration	0: no; 1: yes		Enable setpoint compensation in accordance with the outdoor temperature
56	56	56	R/W OEM	HAB_OFF_VINT_DES	Defrosting	0: no; 1: yes		Enable indoor fan stoppage during defrosting
57	57	57	R/W OEM	HAB_UNICO_VOL_AIRE_EXT	Configuration	0: no; 1: yes		Enable simultaneous defrosting
58	58	58	R/W	AUTOSTART	Regulation	0: no; 1: yes		Enable automatic start-up after blocking/power cut
59	59	59	R/W	HAB_ONOFF_REMOTO	Regulation	0: no; 1: yes		Enable remote ON/OFF
60	60	60	R	HAB_ON_OFF_HOR	Status	0: no; 1: yes		Enable ON-OFF time schedule
61	61	61	R	HAB_CAMBIO_MODO_HOR	Status	0: no; 1: yes		Enable setpoint change time schedule
62	62	62	R/W OEM	HAB_FREECOOL_INV	Configuration	0: no; 1: yes		Enable free-cooling in HEATING mode (winter)
63	63	63	R/W OEM	CONTROL_P_PI	Fan	0: no; 1: yes		Temperature control type: proportional (P) or proportional + integral (P+I)
64	64	64	R/W OEM	HAB_ROT_COMP	Compressor	0: no; 1: yes		Enable rotation of compressors
65	65	65	R/W	SYS_ON	Commands	0: off 1: on		Unit ON/OFF
66	66	66	R/W	CALOR_FRIO_PANEL	Commands	0: winter 1: summer		Select HEATING/COOLING mode via the panel
67	67	67	R/W OEM	HAB_ZONIFICACION_EQUIPO	Configuration	0: no; 1: yes		Enable power and flow reduction for the zoning of the unit
68	68	68	R/W	HAB_ZONIFICACION_1_ZONA	Commands	0: 2 zones 1: 1 zone		Selection of number of active zones (2 zones or 1 zone)
69	69	69	R	RED_CAUDAL_POR_ZONIFICACION	Status	0: disabled 1: enabled		Status of flow reduction in zoning (disable or enable)
70	70	70	R	RED_CAUDAL_AUTOMATICO	Status	0: disabled 1: enabled		Status of flow reduction in automatic flow reduction (disable or enable)
71	71	71	R/W OEM	HAB_CONTROL_SOBREPRESION	Configuration	0: no; 1: yes		Enable OVERPRESSURE control



Carel Addr.	Modbus record	Modbus extended	Read / Write	Variable	Parameter type	Min. value	Max. value	Description
72	72	72	R/W	HAB_BLOQ_COMP_ON_FASE_LIM_FRIO	RTC	0: no; 1: yes		Disable the compressors in summer with scheduling and setpoint limit in summer (freecooling night)
73	73	73	R/W	HAB_BLOQ_RENOVACION_ON_FASE_LIM	RTC	0: no; 1: yes		Disable the outdoor air exchange and scheduling limit setpoint (night)
74	74	74	R	SYS_ON1	Status	0: no; 1: yes		Display of unit status
75	75	75	R/W OEM	HAB_BINATI	Fan	0: no; 1: yes		Condensation fan by maximum pressure
76	76	76	R	Compressor_1_2_F	Digital outp.	0	1	Switch compressor 2 circ.1 (units 2 circ.) or compressor 2 (units 4 circ.)
77	77	77	R	Compressor_2_2_F	Digital outp.	0	1	Switch compressor 2 circ. 2 (units 2 circ.) or compressor 4 (units 4 circ.)
78	78	78	R/W OEM	HAB_Probe_BAT_EXT_1	Config.	0: no; 1: yes		Enable outdoor coil sensor of circuit 1
79	79	79	R/W OEM	HAB_Probe_BAT_EXT_2	Config.	0: no; 1: yes		Enable outdoor coil sensor of circuit 2
80	80	80	R/W OEM	HAB_MB_GAS_LEAKAGE_DETECTOR	Config.	0: no; 1: yes		Enabling gas leakage detector
81	81	81	R	MOD_MOB_GAS_LEAKAGE_CIAT_1.mAl_Offline_ModBus	Alarm	0	1	Communication fault with the gas leakage detector
82	82	82	R	MOD_MOB_GAS_LEAKAGE_CIAT_1.mRelay_Status	Alarm	0	1	Alarm of gas leakage detected
83	83	83	R	MOD_MOB_GAS_LEAKAGE_CIAT_1.mSensor_Fault	Alarm	0	1	Alarm of broken or disconnected sensor of gas leakage detector
84	84	84	R/W OEM	HAB_LIM_CO2	Config.	0: no; 1: yes		CO2 limit enabled
83	83	83	R/W OEM	HAB_Probe_MEZCLA_CON_CO2	Config.	0: no; 1: yes		Enabling mixing air probe with CO2 probe (input B6 or B8 with pLAN CO2 probe)
86	86	86	R/W OEM	HAB_QUEMADOR_GAS	Config.	0: no; 1: yes		Gas burner control enabled
87	87	87	R/W OEM	DESHAB_AL_BP_CALOR	Compress.	0: no; 1: yes		Cancel LP pressure switch in HEATING mode (winter)
88	88	88	R/W OEM	DESHAB_AL_BP_DES	Compress.	0: no; 1: yes		Cancel LP pressure switch during defrosting
89	89	89	R/W OEM	HAB_DES_FIN_MIN_Probe	Defrosting	0: no; 1: yes		End of defrosting with the lowest temperature/pressure sensor value
90	90	90	R/W OEM	HAB_OFF_COMP_DES	Compress.	0: no; 1: yes		Stop compressors before defrosting
91	91	91	R/W OEM	HAB_OFF_COMP_CAMBIO_F_C	Compress.	0: no; 1: yes		Stop compressors before HEATING/COOLING operating mode change
92	92	92	R/W OEM	RES_VER	Fan	0: no; 1: yes		Electrical heaters as support in COOLING mode (summer)
93	93	93	R/W OEM	VLV_VER	Fan	0: no; 1: yes		Hot water coil as support in COOLING mode (summer)
94	94	94	R/W OEM	HAB_OFF_VINT_FRIO	Fan	0: no; 1: yes		Stop indoor fan when stopping the compressors in COOLING mode
95	95	95	R/W OEM	HAB_OFF_VINT_CALOR	Fan	0: no; 1: yes		Stop indoor fan when stopping the compressors in HEATING mode
96	96	96	R/W OEM	Probe_HUM_4_20	Service	0: 0-1V 1: 4-20mA		Type of humidity sensor
97	97	97	R	MOD_MB_VFD_CIAT_2.mAl_Offline_VFD	Alarm	0	1	Communication fault with the frequency inverter of return motor
98	98	98	R/W OEM	HAB_FILTRO1	Service	0: no; 1: yes		Enable sensor filter
99	99	99	R/W OEM	HAB_RES_Defrosting	Config.	0: no; 1: yes		Enable electrical heaters or gas burner during defrosting
100	100	100	R/W OEM	ACC_IMP_VLV	Config.	0: no; 1: yes		Supply air temperature control with auxiliary hot water coil
101	101	101	R/W OEM	ACC_IMP_BC	Config.	0: no; 1: yes		Supply air temperature control with compressors
102	102	102	R/W OEM	ACC_IMP_RES	Config.	0: no; 1: yes		Supply air temperature control with electrical heaters
103	103	103	R/W OEM	HAB_VALVULA_CALOR	Config.	0: no; 1: yes		Enable auxiliary hot water coil (3-way valve)
104	104	104	R	HAB_CO2	Status	0: no; 1: yes		CO2 sensor installed
105	105	105	R/W OEM	RESET_ON_HORAS_COMP1	Service	0: no; 1: yes		Reset operating hours of compressor 1 of circuit 1
106	106	106	R/W OEM	RESET_ON_HORAS_COMP2	Service	0: no; 1: yes		Reset operating hours of compressor 1 of circuit 2 (units 2 circ.) or compressor 3 (units 4 circ.)
107	107	107	R/W OEM	RESET_ON_HORAS_MAQUINA	Service	0: no; 1: yes		Reset operating hours of the unit
108	108	108	R	mAL_SET_HOR_ON_EQUIPO	Alarm	0	1	Alarm due to cumulative unit operating hours
109	109	109	R	mAL_TEMP_RET	Alarm	0	1	Return air temperature sensor alarm
110	110	110	R	mAL_S_VIRTUAL	Alarm	0	1	Virtual pLAN sensor alarm
111	111	111	R	mAL_TEMP_EXT	Alarm	0	1	Outdoor temperature sensor alarm
112	112	112	R	mAL_HUM_RET	Alarm	0	1	Return humidity sensor alarm
113	113	113	R	mAL_HUM_EXT	Alarm	0	1	Outdoor humidity sensor alarm



Carel Addr.	Modbus record	Modbus extended	Read / Write	Variable	Parameter type	Min. value	Max. value	Description
114	114	114	R	mAL_TEMP_IMP	Alarm	0	1	Supply air temperature sensor alarm
115	115	115	R	mAL_SETPOINT	Alarm	0	1	Alarm setpoint HEATING mode (winter) > COOLING mode (summer)
116	116	116	R	IN_DIG11_CR	Digital inp.	0	1	HP and LP pressure switch recovery circuit (only with cooling recovery)
117	117	117	R	Compressor_REC	Digital outp.	0	1	Recovery compressor switch (only with cooling recovery)
118	118	118	R	mAL_AP_BP_CR	Alarm	0	1	HP and LP pressure switch recovery circuit alarm (with cooling recovery)
119	119	119	R	mAL_SET_HOR_CR	Alarm	0	1	Recovery compressor maintenance (only with cooling recovery)
120	120	120	R/W	FORZADO	RTC	0: no; 1: yes		Forced start-up
121	121	121	R/W	NEW_DATE	RTC	0: no; 1: yes		Activate time and date change
122	122	122	R	mAL_SET_HOR_COMP1_2	Alarm	0	1	Maintenance compr. 2 circ. 1 (units 2 circ.) or compr. 2 (units 4 circ.)
123	123	123	R	mAL_SET_HOR_COMP2_2	Alarm	0	1	Maintenance compr. 2 circ. 2 (units 2 circ.) or compr. 4 (units 4 circ.)
124	124	124	R/W OEM	RESET_ON_HORAS_COMP1_2	Service	0: no; 1: yes		Reset operating hours of compressor 2 of circuit 1 (units 2 circ.) or compressor 2 (units 4 circ.)
125	125	125	R/W OEM	RESET_ON_HORAS_COMP2_2	Service	0: no; 1: yes		Reset operating hours of compressor 2 of circuit 2 (units 2 circ.) or compressor 4 (units 4 circ.)
126	126	126	R	mAL_KLD1	Alarm	0	1	Discharge temperature limit of compressor(s) of circ. 1 exceeded
127	127	127	R	mAL_KLD2	Alarm	0	1	Discharge temperature limit of compressor(s) of circ. 2 exceeded
128	128	128	R/W	HAB_PROT_ANTIHELO_BAC_GF	Config.	0: no; 1: yes		Enabling of the antifreeze protection of the hot water coil with low outdoor temperatures
129	129	129	R/W OEM	HAB_BAC_Defrosting	Config.	0: no; 1: yes		Enable auxiliary hot water coil during defrosting
130	130	130	R	mAL_TEMP_MEZCLA	Alarm	0	1	Mixed air temperature sensor alarm
131	131	131	R/W OEM	TIPO_BLOQ_COMP_CALOR	Compress.	0: no; 1: yes		Disable compressors in HEATING mode (winter) according to outdoor temperature
132	132	132	R/W OEM	HAB_PRIORIDAD_BAC	Regulation	0: no; 1: yes		Enable hot water coil priority with respect to compressors
133	133	133	R/W OEM	RESET_ON_HORAS_CR	Service	0: no; 1: yes		Reset operating hours of the recovery compressor
134	134	134	R/W OEM	HAB_PRES_BEXT	Config.	0: temp. 1: pressure		Enable pressure sensors in the outdoor coil
135	135	135	R	IN_DIG12_INC	Digital inp.	0: no; 1: yes		Digital input detection of smoke or fire
136	136	136	R	mAL_INCENDIO	Alarm	0	1	Smoke detector alarm
137	137	137	R/W OEM	HAB_BINATI_EVAP	Fan	0: no; 1: yes		Evaporation fan by minimum pressure
138	138	138	R/W OEM	HAB_DES_TIME	Defrosting	0: no; 1: yes		Enable defrosting by time
139	139	139	R/W OEM	HAB_DES_MIN	Defrosting	0: no; 1: yes		Enable defrosting by minimum pressure/temperature
140	140	140	R/W OEM	HAB_DES_DIF	Defrosting	0: no; 1: yes		Enable defrosting by difference between outdoor temperature and evaporation temperature
141	141	141	R	IN_DIG19_AP1_2	Digital inp.	0	1	HP pressure switch circuit 3
142	142	142	R	IN_DIG20_AP_2_2	Digital inp.	0	1	HP pressure switch circuit 4
143	143	143	R	IN_DIG15_BP1_2	Digital inp.	0	1	LP pressure switch circuit 3
144	144	144	R	IN_DIG16_TC1_2	Digital inp.	0	1	LP pressure switch circuit 4
145	145	145	R	IN_DIG17_BP2_2	Digital inp.	0	1	Thermal compressor 2 of circ. 1 (units 2 circ.) or compressor 2 (units 4 circ.)
146	146	146	R	IN_DIG18_TC2_2	Digital inp.	0	1	Thermal compressor 2 of circuit 2 (units 2 circ.) or compressor 4 (units 4 circ.)
147	147	147	R	OUT_VIC1_2	Digital outp.	0	1	Cycle reversing valve of circuit 3
148	148	148	R	OUT_VIC2_2	Digital outp.	0	1	Cycle reversing valve of circuit 4
149	149	149	R	Fan_EXT_1_2	Digital outp.	0	1	Low-speed outdoor fan circ. 3 & 4 (units 4 circ.)
150	150	150	R	Fan_EXT_2_2	Digital outp.	0	1	High-speed outdoor fan circ. 3 & 4 (units 4 circ.)
151	151	151	R	mAL_TERM_COMP_VEXT_1_2	Alarm	0	1	Alarm for thermal compressor 2 of circuit 1 (units 2 circ.) or compressor 2 (units 4 circ.)
152	152	152	R	mAL_TERM_COMP_VEXT_2_2	Alarm	0	1	Alarm for thermal compressor 2 of circuit 2 (units 2 circ.) or compressor 4 (units 4 circ.)
153	153	153	R	mAL_AP1_2	Alarm	0	1	Alarm due to high pressure of circuit 3
154	154	154	R	mAL_AP2_2	Alarm	0	1	Alarm due to high pressure of circuit 4
155	155	155	R	mAL_BP1_2	Alarm	0	1	Alarm due to low pressure of circuit 3
156	156	156	R	mAL_BP2_2	Alarm	0	1	Alarm due to low pressure of circuit 4
157	157	157	R	mAL_T_P_BEXT_C1_2	Alarm	0	1	Outdoor coil sensor of circuit 3 alarm

Carel Addr.	Modbus record	Modbus extended	Read / Write	Variable	Param. type	Min. value	Max. value	Description
158	158	158	R	mAL_T_P_BEXT_C2_2	Alarm	0	1	Outdoor coil sensor of circuit 4 alarm
159	159	159	R	mAL_KLD1_2	Alarm	0	1	Discharge temperature limit of compressor(s) circuit 3 exceeded
160	160	160	R	mAL_KLD2_2	Alarm	0	1	Discharge temperature limit of compressor(s) circuit 4 exceeded
161	161	161	R	mAI_I_O_Mismatch	Alarm	0	1	Alarm inputs/outputs mismatch of expansion card pCOe (4 compr. / 4 circuits)
162	162	162	R	mAI_Offline	Alarm	0	1	Alarm no comm. with expansion card pCOe (4 compr. / 4 circuits)
163	163	163	R	mAI_Offline	Alarm	0	1	Alarm no communication with ambient sensor RS485 No. 1
164	164	164	R	mAI_Broken_Temp_Probe	Alarm	0	1	Alarm ambient temperature sensor No.1 broken or disconnected
165	165	165	R	mAI_Broken_Humid_Probe	Alarm	0	1	Alarm ambient humidity sensor No.1 broken or disconnected
166	166	166	R	mAL_IMPULSION_ALTA	Alarm	0	1	High supply air temperature alarm
167	167	167	R/W OEM	HAB_MB_SOND_AMB	Config.	0: no; 1: yes		Enable ambient sensor
168	168	168	R/W OEM	HAB_FILTRO_CAL_IMP	Service	0: no; 1: yes		Enable supply air STP calculation with ambient sensor
169	169	169	R/W OEM	HAB_COMP_REG_PRES_U_EXT	Config.	0: no; 1: yes		Enable pressure control damper in the outdoor unit
170	170	170	R/W OEM	COMP_OFF_ALL_INCENDIO	Alarm	0: open 1: closed		Outdoor damper status with fire alarm (0=open, 1=closed)
171	171	171	R/W OEM	HAB_C_COND_VENT_EXT	Fan	0: no; 1: yes		Enable condensation control of outdoor unit
172	172	172	R/W OEM	HAB_C_EVAP_VENT_EXT	Fan	0: no; 1: yes		Enable evaporation control of outdoor unit
173	173	173	R/W	HAB_DETECCION_FALLO_COM_BMS	Special	0	1	Enabling detection of failure of BMS communication to load the default values
174	174	174	R/W	VAR_DETECCION_FALLO_BMS	Special	0	1	Variable to write by the BMS to avoid the detection of failure of BMS communication (1 -> 0)
175	175	175	R	mAI_Offline	Alarm	0	1	Alarm no communication with ambient sensor RS485 No.2
176	176	176	R	mAI_Broken_Temp_Probe	Alarm	0	1	Alarm ambient temperature sensor No.2 broken or disconnected
177	177	177	R	mAI_Broken_Humid_Probe	Alarm	0	1	Alarm ambient humidity sensor No.2 broken or disconnected
178	178	178	R/W OEM	CONTROL_P_PI_C_EVAP_VEXT	Fan	0: P ; 1: P+I		Type of control: P or P + I for outdoor unit evaporation control
179	179	179	R/W OEM	CONTROL_P_PI_C_COND_VEXT	Fan	0: P ; 1: P+I		Type of control: P or P + I for outdoor unit condensation control
180	180	180	R/W OEM	SEL_Alarm_POR_MASK	Alarm	0: no; 1: yes		Relay activation with selected active alarms on display
181	181	181	R/W OEM	HAB_RES_SIN_Compressor	Config.	0: no; 1: yes		Enable electrical heaters for replacing the compressors
182	182	182	R/W OEM	RESET_TIME_Compressor	Service	0: no; 1: yes		Compressor timers reset
183	183	183	R	ON_Defrosting	Status	0	1	Signal from defrosting unit
184	184	184	R	ON_FREECOOL	Status	0	1	Display of the free-cooling operation
185	185	185	R	ON_FREEHEAT	Status	0	1	Display of the free-heating operation
186	186	186	R	ON_Compressor	Status	0	1	Display of the compressors status
187	187	187	R	ON_RESISTENCIA	Status	0	1	Display of the electrical heaters operation
188	188	188	R	NOT_SYSON1	Status	0	1	Display of the unit OFF
189	189	189	R/W OEM	CONTROL_SOND_AMB	Config.	0: return T 1: amb. T		Temperature control by means of ambient temperature sensor
190	190	190	R/W OEM	HAB_MB_ENERGY_METER	Config.	0: no; 1: yes		Enable energy meter connected as Modbus slave
191	191	191	R/W OEM	Reset_Energy	Config.	0: no; 1: yes		Reset of energy meter counter
192	192	192	R	mAI_Offline	Alarm	0	1	Alarm no communication with energy meter
193	193	193	R	mAL_ANTIHIELO_REF_C1	Alarm	0	1	Anti-freeze refrigerant alarm of circuit 1
194	194	194	R	mAL_ANTIHIELO_REF_C2	Alarm	0	1	Anti-freeze refrigerant alarm of circuit 2
195	195	195	R	mAL_ANTIHIELO_REF_C1_2	Alarm	0	1	Anti-freeze refrigerant alarm of circuit 3
196	196	196	R	mAL_ANTIHIELO_REF_C2_2	Alarm	0	1	Anti-freeze refrigerant alarm of circuit 4
197	197	197	R	mAL_BQ_ANTIHIELO	Alarm	0	1	Unit blocking due to anti-freeze refrigerant alarm
198	198	198	R/W OEM	RESET_AL_BQ_ANTIHIELO	Alarm	0: no; 1: yes		Reset of unit blocking due to anti-freeze refrigerant alarm
199	199	199	R	mAL_CAUDAL	Alarm	0	1	Water flow switch digital input alarm (water-air units)
200	200	200	R/W OEM	HAB_ON_VEXT_INI_DES	Defrost.	0: no; 1: yes		Enable outdoor fan connection at start of defrosting
201	201	201	R	mAI_Offline_MB_Ebm_Fan1	Alarm	0	1	Alarm no communication plug-fan indoor fan
202	202	202	R	mAI_sensor_pres_dif_aire	Alarm	0	1	Differential pressure sensor alarm for flow control



Carel Addr.	Modbus record	Modbus extended	Read / Write	Variable	Param. type	Min. value	Max. value	Description
203	203	203	R/W OEM	HAB_BOMBA_CALOR_COMP_REC	Config.	0:ccoling only 1:heat pump		Recovery compressor - Heat pump
204	204	204	R/W OEM	HAB_OFF_VINT_POR_CO2	Fan	0: no; 1: yes		Indoor fan stop when compressor stops if there is no demand for air renewal by CO2 sensor
205	205	205	R	mAl_Offline_MB_Ebm_Fan2	Alarm	0	1	Plug-fan return fan alarm no communication
206	206	206	R	mAl_sensor_pres_dif_aire_Fan2	Alarm	0	1	Differential pressure sensor alarm for return flow control
207	207	207	R/W	HAB_RED_CAUDAL_CON_COMP_TANDEM	Commands	0: no; 1: yes		Enable the automatic reduction of flow with 50% power in tandem compressors
--	--	208	R/W OEM	HAB_VALVULA_FRIO	Config.	0: no; 1: yes		Enable auxiliary cold water coil (3-way valve)
--	--	209	R/W	HAB_PRIORIDAD_VALV_FRIO	Regulation	0: no; 1: yes		Enable hot water cold priority with respect to compressors
--	--	210	R	mAl_I_O_Mismatch	Alarm	0	1	Alarm expansion card pCOe inputs/outputs malfunction n.2
--	--	211	R	mAl_Offline	Alarm	0	1	Alarm no communication with expansion card pCOe n.2
--	--	212	R	mAl_T_P_BINT_C1	Alarm	0	1	Indoor coil sensor of circuit 1 alarm
--	--	213	R	mAl_T_P_BINT_C2	Alarm	0	1	Indoor coil sensor of circuit 2 alarm
--	--	214	R	mAl_T_P_BINT_C1_2	Alarm	0	1	Indoor coil sensor of circuit 3 alarm
--	--	215	R	mAl_T_P_BINT_C2_2	Alarm	0	1	Indoor coil sensor of circuit 4 alarm
--	--	216	R/W OEM	HAB_C_EVAP_VENT_INT	Fan	0: no; 1: yes		Enable evaporation control of indoor unit
--	--	217	R/W OEM	HAB_C_COND_VENT_INT	Fan	0: no; 1: yes		Enable condensation control of indoor unit
--	--	218	R/W OEM	HAB_VALV_CALOR_POR_IMP_MIN_CALOR	Config.	0: no; 1: yes		Supply minimum control with hot water coil with unit in HEATING mode
--	--	219	R/W OEM	HAB_COMP_CALOR_POR_IMP_MIN_CALOR	Config.	0: no; 1: yes		Supply minimum control with compressors in heating with unit in HEATING mode
--	--	220	R/W OEM	HAB_RES_POR_IMP_MIN_CALOR	Config.	0: no; 1: yes		Supply min. control with electrical heaters in HEATING mode
--	--	221	R	mAl_TEMP_ENTRADA_BAC	Alarm	0	1	Alarm of water inlet temperature of the hot water coil probe
--	--	222	R	mAl_TEMP_SALIDA_BAC	Alarm	0	1	Alarm of water outlet temperature of the hot water coil probe
--	--	223	R	mAl_ANTIHIELO_AGUA_BAC	Alarm	0	1	Water anti-freeze alarm of hot water coil
--	--	224	R	mAl_TEMP_AMB	Alarm	0	1	Alarm of ambient air temperature sensor
--	--	225	R	mBQ_AL_BP1_Defrosting	Alarm	0	1	Alarm of low pressure of circuit 1 by continuous defrosting by minimum pressure or temperature
--	--	226	R	mBQ_AL_BP2_Defrosting	Alarm	0	1	Alarm of low pressure of circuit 2 by continuous defrosting by minimum pressure or temperature
--	--	227	R	mBQ_AL_BP1_2_Defrosting	Alarm	0	1	Alarm of low pressure of circuit 3 by continuous defrosting by minimum pressure or temperature
--	--	228	R	mBQ_AL_BP2_2_Defrosting	Alarm	0	1	Alarm of low pressure of circuit 4 by continuous defrosting by minimum pressure or temperature
--	--	229	R/W OEM	HAB_BM_TERMOSTATO_TCO	Config.	0: no; 1: yes		Enabling of the TCO thermostat by MODBUS
--	--	230	R/W OEM	ThTune_bloqueado	Config.	0: no; 1: yes		Keypad lock of the TCO thermostat
--	--	231	R/W OEM	HAB_EQUIPO_100_AIRE_EXTERIOR	Config.	0: no; 1: yes		Enabling of unit operation with 100% outdoor aire
--	--	232	R/W OEM	MODO_FRIO_CALOR_AUTO	Config.	0: indoor T 1: outdoor T		COOLING/HEATING switching in AUTO mode
--	--	233	R/W OEM	HAB_RENOVACION_AIRE	Config.	0: no; 1: yes		Enabling of outdoor air for refreshing
--	--	234	R/W OEM	REG_ANTI_INCENDIO_FRA_ERP	Alarm	0: no; 1: yes		Enabling ERP French fire safety
--	--	235	R	MODO_CALOR_SIN_FC_INV	Status	0: no; 1: yes		HEATING operating mode without freecooling winter
--	--	236	R	MODO_VENT	Status	0: no; 1: yes		ONLY VENTILATION operating mode
--	--	237	R/W	HAB_MB_THERMAL_ENERGY_METER	Config.	0: no; 1: yes		Enabling COOLING / HEATING power meter
--	--	238	R	ON_LIMITE_TEMP_IMPULSION	Status	0: no; 1: yes		Signal of the operating unit with supply temperature limit
--	--	239	R/W	HAB_ZONIFICACION_POR_COMPUERTAS	Config.	0: no; 1: yes		Enabling of the zoning by dampers (expansion module I/O)
--	--	240	R/W	PGD1_bloqueado_SEL_FRIO_CALOR	Config.	0: no; 1: yes		Enabling of the blocking of summer / winter selection in the PGD1
--	--	241	R/W	HAB_LIM_POT_COMP_TANDEM_POR_AP	Service	0: no; 1: yes		Enabling power limitation in tandem compressor by high pressure
--	--	242	R	OFF_PROG_HOR	Status	0: no; 1: yes		Signaling of the OFF by scheduling by TCO or PGD
--	--	243	R/W	POS_COMPUERTA_FRIO_AL_INICIO	Regulat.	0: normal 1: closed		Select outdoor air damper position at start-up in COOLING mode
--	--	244	R/W	HAB_COMPENSACION_POWER_FACTOR	Config.	0: no; 1: yes		Power factor setpoint

6.3. Analogue variables

Carel Addr.	Modbus record	Modbus extended	Read/Write	Variable	Parameter type	UOM	Min. value	Max. value	Description
1	1	1	R	TEMP_RET	Analog input	°C	-99.9	99.9	Return air temperature
2	2	2	R	TEMP_EXT	Analog input	°C	-99.9	99.9	Outdoor air temperature
3	3	3	R	T_P_BEXT_C1	Analog input	BAR	-99.9	99.9	Temperature or pressure outdoor coil circuit 1
4	4	4	R	T_P_BEXT_C2	Analog input	BAR	-99.9	99.9	Temperature or pressure outdoor coil circuit 2
5	5	5	R	HUM_REG	Analog input	%rH	-999.9	999.9	Return air relative humidity
6	6	6	R	HUM_EXT	Analog input	%rH	-999.9	999.9	Outdoor air relative humidity
7	7	7	R	TEMP_IMP	Analog input	°C	-99.9	99.9	Supply air temperature
8	8	8	R	TEMP_MEZCLA	Analog input	°C	-99.9	99.9	Mixing air temperature
9	9	9	R	TEMP_AMB	Analog input	°C	-99.9	99.9	Ambient air temperature
10	10	10	R	AOUT_COMPUERTA	Analog output	---	0	32767	Outdoor air damper outlet
11	11	11	R	AOUT_BAC_O_RES_PROP_O_COMP_INV	Analog output	---	0	32767	Modulating output for auxiliary hot water coil valve
12	12	12	R	AOUT_VEN_EXT1	Analog output	---	0	32767	Modulating output for electronic outdoor fan circ. 1 (unit 1 or 2 circ.) or circ. 1 and 2 (units 4 circ.)
13	13	13	R	AOUT_VEN_EXT2	Analog output	---	0	32767	Modulating output for electronic outdoor fan circ. 2 (units 2 circ.) or circ. 3 and 4 (units 4 circ.)
14	14	14	R	TEMP_TCO	Analog input	°C	-99.9	99.9	Air temperature of the TCO thermostat
15	15	15	R/W	SET_POINT_TEMP_FRIO	Commands	°C	LIM_INF_TEMP	LIM_SUP_TEMP	Return air temperature setpoint in COOLING mode (summer)
16	16	16	R/W	SET_POINT_TEMP_CALOR	Commands	°C	LIM_INF_TEMP	LIM_SUP_TEMP	Return air temperature setpoint in HEATING mode (winter)
17	17	17	R/W	BANDA_HUMEDAD	Regulation	%rH	0	99.9	Humidity control differential in COOLING mode (summer)
18	18	18	R/W	SET_POINT_HUM	Commands	%rH	LIM_INF_HUM	LIM_SUP_HUM	Humidity control setpoint in COOLING mode (summer)
19	19	19	R/W	LIM_SUP_TEMP_FRIO	Regulation	°C	LIM_INF_TEMP	50.0	Upper limit of temperature setpoint on COOLING
20	20	20	R/W	LIM_INF_TEMP_FRIO	Regulation	°C	0	LIM_SUP_TEMP	Lower limit of temperature setpoint on COOLING
21	21	21	R/W	BANDA_TEMP_FRIO	Regulation	°C	0	15.0	COOLING mode (summer) temperature control band
22	22	22	R/W	BANDA_TEMP_CALOR	Regulation	°C	0	15.0	HEATING mode (winter) temperature control band
23	23	23	R/W	LIM_SUP_HUM	Regulation	%rH	LIM_INF_HUM	99.9	Humidity setpoint upper limit
24	24	24	R/W	LIM_INF_HUM	Regulation	%rH	-99.9	LIM_SUP_HUM	Humidity setpoint lower limit
25	25	25	R	TEMP_ENTRADA_BAC	Analog input	°C	-99.9	99.9	Water inlet temperature of the hot water coil
26	26	26	R	TEMP_SALIDA_BAC	Analog input	°C	-99.9	99.9	Water outlet temperature of the hot water coil
27	27	27	R/W	DELTA_FREE_COOL	Regulation	°C	-5.0	5.0	Temperature differential for free-cooling
28	28	28	R/W	OFFSET_FCOOL	Regulation	°C	-5.0	5.0	Free-cooling ramp in COOLING mode (summer): Offset
29	29	29	R/W	DIF_FCOOL	Regulation	°C	0	5.0	Free-cooling ramp in COOLING mode (summer): Differential
30	30	30	R/W	OFFSET_FHEAT	Regulation	°C	-5.0	5.0	Free-heating ramp in HEATING mode (winter): Offset
31	31	31	R/W	DIF_FHEAT	Regulation	°C	0	5.0	Free-heating ramp in HEATING mode (winter): Differential
32	32	32	R/W	SET_IMPULSION_FRIO_MIN	Regulation	°C	0	SET_IMPULSION_FRIO_MAX	Setpoint for minimum supply air temperature control in COOLING mode (summer)
33	33	33	R/W	BANDA_IMP_FRIO	Regulation	°C	0	20.0	Minimum supply air temperature control differential in COOLING mode (summer)
34	34	34	R/W	SET_COMP_EXT_FRIO	Regulation	°C	-99.9	99.9	Outdoor temperature compensation setpoint in COOLING mode (summer)
35	35	35	R/W	VAL_DIF_COMP_EXT_FRIO	Regulation	°C	-99.9	99.9	Outdoor temperature compensation differential in COOLING mode (summer)
36	36	36	R/W	MAX_COMP_EXT_FRIO	Regulation	°C	0	99.9	Maximum compensation in COOLING mode (summer)
37	37	37	R/W OEM	VAL_INI_DES	Regulation	BAR	-10.0	10.0	Defrosting start-up setpoint
38	38	38	R/W OEM	VAL_FIN_DES	Regulation	BAR	0	50.0	Defrosting stop setpoint



Carel Addr.	Modbus record	Modbus extended	Read / Write	Variable	Parameter type	UOM	Min. value	Max. value	Description
39	39	39	R/W	ZONA_MUERTA_TEMP	Regulation	°C	0	3.0	Dead zone temperature control
40	40	40	R/W	ZONA_MUERTA_HUM	Regulation	%rH	0	50.0	Dead zone humidity control
41	41	41	R/W OEM	SET_ALTA_TEMP_FRIO	Alarm	°C	0	60.0	Return air high temperature setpoint in COOLING mode (summer)
42	42	42	R/W OEM	SET_BAJA_TEMP_FRIO	Alarm	°C	0	60.0	Return air low temperature setpoint in COOLING mode (summer)
43	43	43	R/W OEM	SET_ALTA_TEMP_CALOR	Alarm	°C	0	60.0	Return air high temperature setpoint in HEATING mode (winter)
44	44	44	R/W OEM	SET_BAJA_TEMP_CALOR	Alarm	°C	0	60.0	Return air low temperature setpoint in HEATING mode (winter)
45	45	45	R/W OEM	TAR_TEMP_RET	Service	°C	-9.9	9.9	Calibration of return air sensor
46	46	46	R/W OEM	TAR_TEMP_EXT	Service	°C	-9.9	9.9	Calibration of outdoor air sensor
47	47	47	R/W OEM	TAR_TEMP_IMP	Service	°C	-9.9	9.9	Calibration of supply air sensor
48	48	48	R/W OEM	TAR_T_P_BEXT_C1	Service	BAR	-9.9	9.9	Calibration of outdoor coil sensor circuit 1
49	49	49	R/W OEM	TAR_T_P_BEXT_C2	Service	BAR	-9.9	9.9	Calibration of outdoor coil sensor circuit 2
50	50	50	R/W OEM	TAR_TEMP_MEZCLA	Service	°C	-9.9	9.9	Calibration of mixing air sensor
51	51	51	R/W OEM	OFFSET_TEMP_AGUA_BAC	Config.	°C	0	10.0	Water temperature offset of the hot water coil with OFF unit
52	52	52	R/W	OFFSET_RES	Regulation	°C	-5.0	5.0	Offset for the control of electrical heaters or gas burner
53	53	53	R/W	DIF_RES	Regulation	°C	0	5.0	Differential control for electrical heaters or gas burner
54	54	54	R/W OEM	TAR_HUM_AMB	Service	%rH	-9.9	9.9	Calibration of return humidity sensor
55	55	55	R/W OEM	TAR_HUM_EXT	Service	%rH	-9.9	9.9	Calibration of outdoor humidity sensor
56	56	56	R/W OEM	SET_TEMP_AGUA_BAC	Config.	°C	0	20.0	Water temperature setpoint of the hot water coil
57	57	57	R/W OEM	BANDA_TEMP_AGUA_BAC	Config.	°C	0	5.0	Band of the water temperature setpoint of the hot water coil
58	58	58	R/W	SET_EXT_CALOR	RTC	°C	-99.9	99.9	Time schedule with setpoint change: HEATING mode (winter) outdoor setpoint
59	59	59	R/W	SET_EXT_FRIO	RTC	°C	-99.9	99.9	Time schedule with setpoint change: COOLING mode (summer) outdoor setpoint
60	60	60	R/W	SET_INT_CALOR	RTC	°C	-99.9	99.9	Time schedule with setpoint change: HEATING mode (winter) indoor setpoint
61	61	61	R/W	SET_INT_FRIO	RTC	°C	-99.9	99.9	Time schedule with setpoint change: COOLING mode (summer) indoor setpoint
62	62	62	R/W	OFFSET_VALV	Regulation	°C	-10.0	0	Auxiliary hot water coil offset (heat valve)
63	63	63	R/W	DIF_VALV	Regulation	°C	0	5.0	Auxiliary hot water coil differential (heat valve)
64	64	64	R/W	SET_COMP_EXT_CALOR	Regulation	°C	-99.9	99.9	Outdoor temperature compensation setpoint in HEATING mode (winter)
65	65	65	R/W	VAL_DIF_COMP_EXT_CALOR	Regulation	°C	-99.9	99.9	Outdoor temperature compensation differential in HEATING mode (winter)
66	66	66	R/W	MAX_COMP_EXT_CALOR	Regulation	°C	0	99.9	Maximum compensation in HEATING mode (winter)
67	67	67	R/W OEM	SET_C_COND_VEXT	Fan	BAR	0	60.0	Outdoor fan condensation control setpoint
68	68	68	R/W OEM	VAL_INI_VEXT_ALTA_VEL_COND	Config.	BAR	0	60.0	Initial value of the outdoor fan at high speed in condensation
69	69	69	R/W OEM	BANDA_C_COND_VEXT	Fan	BAR	0	10.0	Outdoor fan condensation control differential
70	70	70	R/W OEM	VAL_FIN_VEXT_ALTA_VEL_COND	Config.	BAR	0	60.0	Final value of the outdoor fan at high speed in condensation
71	71	71	R/W OEM	LIM_MAX_HUM	Service	%rH	0	100.0	Maximum humidity limit
72	72	72	R/W OEM	LIM_MIN_HUM	Service	%rH	0	100.0	Minimum humidity limit
73	73	73	R/W	OFFRESVER	Regulation	°C	-99.9	0	Offset for support with electrical heaters in COOLING mode (summer) due to low return temperature
74	74	74	R/W	OFFVLVVER	Regulation	°C	-99.9	0	Offset for support with hot water coil in COOLING mode (summer) due to low return temperature
75	75	75	R	VER_SOFT	Status	---	0	99.9	µPC MEDIUM board software version
76	76	76	R/W	SET_EXT_LIM_CALOR	RTC	°C	-99.9	99.9	Time schedule on by limit setpoint in HEATING mode (winter): limit setpoint
77	77	77	R/W	SET_EXT_LIM_FRIO	RTC	°C	-99.9	99.9	Time schedule on by limit setpoint in COOLING mode (summer): limit setpoint
78	78	78	R/W	SET_INT_LIM_CALOR	RTC	°C	-99.9	99.9	Time schedule on by limit setpoint in HEATING mode (winter): indoor setpoint
79	79	79	R/W	SET_INT_LIM_FRIO	RTC	°C	-99.9	99.9	Time schedule on by limit setpoint in COOLING mode (summer): indoor setpoint

Carel Addr.	Modbus record	Modbus extended	Read / Write	Variable	Parameter type	UOM	Min. value	Max. value	Description
80	80	80	R/W	DIF_LIM_FRIO	RTC	°C	0	99.9	Time schedule on by limit setpoint in COOLING mode (summer): limit differential
81	81	81	R/W	DIF_LIM_CALOR	RTC	°C	0	99.9	Time schedule on by limit setpoint in HEATING mode (winter): limit differential
82	82	82	R/W OEM	SET_AL_BAJA_TEXT	Config.	°C	-10.0	10.0	Setpoint for hot water coil ON with unit OFF due to low outdoor temperature
83	83	83	R/W	SET_IMPULSION_CALOR_MAX	Regulation	°C	SET_IMPULSION_CALOR_MIN	55.0	Setpoint for maximum supply air temperature control in HEATING mode (winter)
84	84	84	R/W	BANDA_IMP_CALOR	Regulation	°C	0	20.0	Differential for maximum supply air temperature control in HEATING mode (winter)
85	85	85	R/W OEM	SET_IMPULSION_CALOR_FC	Config.	°C	0	50.0	Supply air temperature setpoint for turning OFF the outdoor air damper in HEATING mode (winter)
86	86	86	R/W OEM	SET_TEMP_OFF_FC_CALOR	Config.	°C	0	50.0	Return air temperature setpoint for turning OFF the outdoor air damper in HEATING mode (winter)
87	87	87	R/W OEM	BANDA_TEMP_OFF_FC_CALOR	Config.	°C	0	5.0	Control band for turning OFF the outdoor air damper in HEATING mode (winter)
88	88	88	R/W OEM	SET_IMPULSION_FRIO_FC	Config.	°C	0	50.0	Supply air temperature setpoint for turning OFF the outdoor air damper in COOLING mode (summer)
89	89	89	R/W OEM	SET_TEMP_OFF_FC_FRIO	Config.	°C	0	50.0	Return air temperature setpoint for turning OFF the outdoor air damper in COOLING mode (summer)
90	90	90	R/W OEM	BANDA_TEMP_OFF_FC_FRIO	Config.	°C	0	5.0	Control band for turning OFF the outdoor air damper in COOLING mode (summer)
91	91	91	R/W OEM	SET_TEMP_MEZ	Config.	°C	0	20.0	Mixed air temperature setpoint for turning OFF the outdoor air damper in HEATING mode (winter)
92	92	92	R/W OEM	SET_BLOQ_COMP_FRIO_FC	Compres.	°C	-99.9	99.9	Block compressor setpoint in COOLING mode (summer) with free-cooling by outdoor temperature
93	93	93	R/W OEM	VAL_DIF_BLOQ_COMP_FRIO_FC	Compres.	°C	-99.9	99.9	Block compressor setpoint in COOLING mode with free-cooling by delta ambient T - outdoor T
94	94	94	R/W OEM	SET_BLOQ_COMP_CALOR	Compres.	°C	-99.9	99.9	Block compressor setpoint in HEATING mode (winter) by outdoor temperature
95	95	95	R/W OEM	VAL_ON_VEXT_DES_OBL	Defrosting	BAR	10.0	45.0	Outdoor fan connection setpoint during the defrosting procedure
96	96	96	R/W OEM	VAL_OFF_VEXT_DES_OBL	Defrosting	BAR	10.0	45.0	Outdoor fan disconnection setpoint during the defrosting procedure
97	97	97	R/W OEM	IS_PRESION	Service	BAR	-2.0	50.0	Initial pressure transducer setpoint
98	98	98	R/W OEM	FS_PRESION	Service	BAR	0	50.0	Final pressure transducer setpoint
99	99	99	R/W OEM	SET_TEMP_CO2	Config.	°C	10.0	20.0	Temperature setpoint for turning OFF the outdoor air damper in HEATING mode (winter) with CO2 sensor
100	100	100	R/W OEM	SET_C_EVAP_VEXT	Fan	BAR	0	60.0	Outdoor fan evaporation control setpoint
101	101	101	R/W OEM	VAL_FIN_VEXT_ALTA_VEL_EVAP	Config.	BAR	0	60.0	Final value of the outdoor fan at high speed in evaporation
102	102	102	R/W OEM	BANDA_C_EVAP_VEXT	Fan	BAR	0	10.0	Outdoor fan evaporation control differential
103	103	103	R/W OEM	VAL_INI_VEXT_ALTA_VEL_EVAP	Config.	BAR	0	60.0	Initial value of the outdoor fan at high speed in evaporation
104	104	104	R/W OEM	VAL_DES_MIN	Defrosting	BAR	-25.0	10.0	Initial defrosting setpoint by min. pressure / T
105	105	105	R/W OEM	VAL_DES_DIF	Defrosting	°C	5.0	20.0	Initial defrosting setpoint by difference between outdoor temperature and evaporation temperature
106	106	106	R	T_P_BEXT_C1_2	An. input	BAR	-99.9	99.9	Temperature or pressure outdoor coil circuit 3
107	107	107	R	T_P_BEXT_C2_2	An. input	BAR	-99.9	99.9	Temperature or pressure outdoor coil circuit 4
108	108	108	R/W OEM	TAR_TEMP_AMB	Service	°C	-9.9	9.9	Calibration of ambient air temperature sensor
109	109	109	R/W OEM	TAR_T_P_BEXT_C1_2	Service	BAR	-9.9	9.9	Calibration of outdoor coil sensor circuit 3
110	110	110	R/W OEM	TAR_T_P_BEXT_C2_2	Service	BAR	-9.9	9.9	Calibration of outdoor coil sensor circuit 4
111	111	111	R/W OEM	SET_TEXT_VEXT_OFF_DES	Defrosting	°C	-9.9	0	Outdoor temperature setpoint for non-activation of outdoor fans during defrosting
112	112	112	R/W	OFFSET_CAL_IMP_CALOR	Regulation	°C	0	30.0	Ambient T compensation in order to calculate supply air setpoint in HEATING mode (winter)
113	113	113	R/W	SET_IMPULSION_CALOR_MIN	Regulation	°C	25.0	SET_IMPULSION_CALOR_MAX	Setpoint for minimum supply air temperature control in HEATING mode (winter)
114	114	114	R/W	OFFSET_CAL_IMP_FRIO	Regulation	°C	0	30.0	Ambient temperature compensation to calculate supply air setpoint in COOLING mode (summer)
115	115	115	R/W	SET_IMPULSION_FRIO_MAX	Regulation	°C	SET_IMPULSION_FRIO_MIN	30.0	Setpoint for maximum supply air temperature control in COOLING mode (summer)
116	116	116	R/W OEM	SET_AL_INCENDIO	Alarm	°C	40.0	80.0	Fire alarm setpoint (return air temperature)
117	117	117	R/W OEM	DIF_AL_INCENDIO	Alarm	°C	10.0	50.0	Fire alarm differential (return air temperature)



Carel Addr.	Modbus record	Modbus extended	Read / Write	Variable	Parameter type	UOM	Min. value	Max. value	Description
118	118	118	R/W OEM	OFFSET_AL_IMPULSION_ALTA	Alarm	°C	0	20.0	Setpoint compensation for high supply air temperature alarm
119	119	119	R/W OEM	DIF_AL_IMPULSION_ALTA	Alarm	°C	1.0	10.0	Differential for high supply air temperature alarm
120	120	120	R/W	SET_QUEMADOR_BAJA_TEXT	Commands	°C	-10.0	10.0	Outdoor temperature setpoint to activate gas burner instead of the compressors
121	121	121	R	SET_IMPULSION_CALOR_CAL	Status	°C	0	55.0	Supply air setpoint calculated in HEATING mode (winter)
122	122	122	R	SET_IMPULSION_FRIO_CAL	Status	°C	0	30.0	Supply air setpoint calculated in COOLING mode (summer)
123	123	123	R	TEMP_CAL_BEXT_C1	An. input	°C	-99.9	99.9	Temp. calculated for the outdoor coil circuit 1
124	124	124	R	TEMP_CAL_BEXT_C2	An. input	°C	-99.9	99.9	Temp. calculated for the outdoor coil circuit 2
125	125	125	R	TEMP_CAL_BEXT_C1_2	An. input	°C	-99.9	99.9	Temp. calculated for the outdoor coil circuit 3
126	126	126	R	TEMP_CAL_BEXT_C2_2	An. input	°C	-99.9	99.9	Temp. calculated for the outdoor coil circuit 4
127	127	127	R/W	VAR_ANALOGICA_AUX_PVPRO_1	Special	---	-3276.8	3276.7	Analogue variable No.1 saved for the PVPRO
128	128	128	R/W	VAR_ANALOGICA_AUX_PVPRO_2	Special	---	-3276.8	3276.7	Analogue variable No.2 saved for the PVPRO
129	129	129	R/W	SET_HAB_RES_TEMP_EXT	Regulation	°C	-20.0	40.0	Setpoint for electrical heaters enabling due to low outdoor temperature
130	130	130	R/W OEM	SET_HUM_OFF_COMPUERTA	Config.	%rH	0	100.0	Humidity setpoint for closing the outdoor air damper
131	131	131	R	Current_1_L_SPV	Status	A	0	999.9	Current line 1
132	132	132	R	Current_2_L_SPV	Status	A	0	999.9	Current line 2
133	133	133	R	Current_3_L_SPV	Status	A	0	999.9	Current line 3
134	134	134	R	Apparent_Power_1_L_SPV	Status	kVAr	0	999.9	Reactive power line 1
135	135	135	R	Apparent_Power_2_L_SPV	Status	kVAr	0	999.9	Reactive power line 2
136	136	136	R	Apparent_Power_3_L_SPV	Status	kVAr	0	999.9	Reactive power line 3
137	137	137	R	Power_1_L_SPV	Status	kW	0	999.9	Effective power line 1
138	138	138	R	Power_2_L_SPV	Status	kW	0	999.9	Effective power line 2
139	139	139	R	Power_3_L_SPV	Status	kW	0	999.9	Effective power line 3
140	140	140	R	Power_L_SPV	Status	kW	0	999.9	Equivalent power
141	141	141	R	VT_L_SPV	Status	---	0	9999	Multiplier of the voltage transformer
142	142	142	R	Frequency	Status	Hz	0	99.9	Frequency of power supply
143	143	143	R/W OEM	VAL_INI_AL_ANTIHIELO	Alarm	°C	VAL_INI_FORCE_AL_ANTIHIELO	50.0	Initial value of the anti-freeze alarm (water-air units)
144	144	144	R/W OEM	VAL_DIF_AL_ANTIHIELO	Alarm	°C	0	50.0	Differential value of anti-freeze alarm (water-air)
145	145	145	R/W OEM	DIF_TEMP_RENOVACION_CAL	Service	°C	0	9.9	Temperature differential for the calculated renovation
146	146	146	R/W OEM	LIM_MIN_HUM_Alarm	Service	%rH	0	100.0	Minimum humidity limit for alarm signalling
147	147	147	R/W OEM	LIM_MAX_HUM_Alarm	Service	%rH	0	100.0	Maximum humidity limit for alarm signalling
148	148	148	R/W	LIM_SUP_TEMP_CALOR	Regulation	°C	LIM_INF_TEMP_CALOR	50.0	Upper limit of temperature setpoint in HEATING
149	149	149	R/W	LIM_INF_TEMP_CALOR	Regulation	°C	0	LIM_SUP_TEMP_CALOR	Lower limit of temperature setpoint in HEATING
150	150	150	R/W	PORC_CAUDAL_50_PORC_COMP_TANDEM	Commands	%	50	75	% flow of fan with selection of automatic flow reduction
151	151	151	R	SOBREPRESION	Status	%	0	99.9	Calculation of the OVERPRESSURE
152	152	152	R/W	CTE_AJUSTE_SOBREPRESION	Service	---	0	10	Constant adjustment of the calculation of the OVERPRESSURE
153	153	153	R	AOUT_COMPUERTA_EXTRACCION	An. output	---	0	999.9	Output extraction air damper
154	154	154	R	SET_HUM_BLOQ_COMP_FRIO_FC	Compressor	%rH	0	100	Block compressor setpoint in summer with free-cooling with high outdoor humidity
155	155	155	R/W OEM	Pda_VENT_INT_min	Service	Pa	0	9999	Point differential pressure minimum of indoor fan
156	156	156	R/W OEM	Rpm_VENT_INT_min	Service	rpm	0	9999	Point rpm minimum of indoor fan
157	157	157	R/W OEM	Pda_VENT_INT_max	Service	Pa	0	9999	Point differential pressure maximum of indoor fan
158	158	158	R/W OEM	Rpm_VENT_INT_max	Service	rpm	0	9999	Point rpm maximum of indoor fan

Carel Addr.	Modbus record	Modbus extended	Read / Write	Variable	Param. type	UOM	Min. value	Max. value	Description
159	159	159	R/W OEM	Speed_Input_perc_VENTILACION_Fan1	Service	%	0	100	% of speed modulation in VENTILATION mode with indoor fan
160	160	160	R/W OEM	Speed_Input_perc_FRIO_Fan1	Service	%	0	100	% of speed modulation in COOLING mode with indoor fan
161	161	161	R/W OEM	Speed_Input_perc_CALOR_Fan1	Service	%	0	100	% of speed modulation in HEATING mode with indoor fan
162	162	162	R	Speed_Hz_VFD_INT	Status	Hz	0	99.9	Frequency read on the indoor motor
163	163	163	R	Analog_IN1_Ebm_Fan1	Status	Pa	0	32767	Pressure differential read on the indoor fan
164	164	164	R	Speed_rpm_VFD_INT	Status	rpm	0	9999	Speed read on the indoor motor
165	165	165	R	Rpm_VENT_INT_calculado	Status	rpm	0	32767	Speed calculated on the indoor fan
166	166	166	R	MOD_MB_VFD_CIAT_1.Min_Setting_A1	Status	%	0	1000.0	Min. value of the analog input A1 of indoor motor VFD
167	167	167	R	MOD_MB_VFD_CIAT_1.Max_Setting_A1	Status	%	0	1000.0	Max. value of the analog input A1 of indoor motor VFD
168	168	168	R	MOD_MB_VFD_CIAT_1.Min_Frequency	Status	Hz	0	320.0	Minimum frequency value of indoor motor VFD
169	169	169	R	MOD_MB_VFD_CIAT_1.Max_Frequency	Status	Hz	0	320.0	Maximum frequency value of indoor motor VFD
170	170	170	R/W OEM	Pda_VENT_RET_min	Service	Pa	0	9999	Point differential pressure minimum of return fan
171	171	171	R/W OEM	Rpm_VENT_RET_min	Service	rpm	0	9999	Point rpm minimum of return fan
172	172	172	R/W OEM	Pda_VENT_RET_max	Service	Pa	0	9999	Point differential pressure maximum of return fan
173	173	173	R/W OEM	Rpm_VENT_RET_max	Service	rpm	0	9999	Point rpm maximum of return fan
174	174	174	R/W OEM	Speed_Input_perc_VENTILACION_Fan2	Service	%	0	100	% of speed modulation in VENTILATION mode with return fan
175	175	175	R/W OEM	Speed_Input_perc_FRIO_Fan2	Service	%	0	100	% speed modulation in COOLING mode with return fan
176	176	176	R/W OEM	Speed_Input_perc_CALOR_Fan2	Service	%	0	100	% speed modulation in HEATING mode with return fan
177	177	177	R	Speed_Hz_VFD_RET	Status	Hz	0	99.9	Frequency read on the return motor
178	178	178	R	Analog_IN1_Ebm_Fan2	Status	Pa	0	32767	Pressure differential read on the return fan
179	179	179	R	Speed_rpm_VFD_RET	Status	rpm	0	9999	Speed read on the return motor
180	180	180	R	Rpm_VENT_RET_calculado	Status	rpm	0	32767	Speed calculated on the return fan
181	181	181	R	MOD_MB_VFD_CIAT_2.Min_Setting_A1	Status	%	0	1000.0	Min. value of the analog input A1 of return motor VFD
182	182	182	R	MOD_MB_VFD_CIAT_2.Max_Setting_A1	Status	%	0	1000.0	Max. value of the analog input A1 of return motor VFD
183	183	183	R	MOD_MB_VFD_CIAT_2.Min_Frequency	Status	Hz	0	320.0	Minimum frequency value of return motor VFD
184	184	184	R	MOD_MB_VFD_CIAT_2.Max_Frequency	Status	Hz	0	320.0	Maximum frequency value of return motor VFD
185	185	185	R/W	NUM_WO_DIG_1	Config.	---	0	9	Work Order Number of unit - DIGIT 1
186	186	186	R/W	NUM_WO_DIG_2	Config.	---	0	9	Work Order Number of unit - DIGIT 2
187	187	187	R/W	NUM_WO_DIG_3	Config.	---	0	9	Work Order Number of unit - DIGIT 3
188	188	188	R/W	NUM_WO_DIG_4	Config.	---	0	9	Work Order Number of unit - DIGIT 4
189	189	189	R/W	NUM_WO_DIG_5	Config.	---	0	9	Work Order Number of unit - DIGIT 5
190	190	190	R/W	NUM_WO_DIG_6	Config.	---	0	9	Work Order Number of unit - DIGIT 6
191	191	191	R/W	NUM_WO_DIG_7	Config.	---	0	9	Work Order Number of unit - DIGIT 7
192	192	192	R/W	NUM_WO_DIG_8	Config.	---	0	9	Work Order Number of unit - DIGIT 8
193	193	193	R/W	SOND_AMB_1_TEMP	Status	°C	-99.9	99.9	Room probe nº 1 - temperature value
194	194	194	R/W	SOND_AMB_1_HUM	Status	%rH	0.0	99.9	Room probe nº 1 - humidity value
195	195	195	R/W	SOND_AMB_1_ROCIO	Status	°C	-99.9	99.9	Room probe nº 1 - dew point
196	196	196	R/W	SOND_AMB_2_TEMP	Status	°C	-99.9	99.9	Room probe nº 2 - temperature value
197	197	197	R/W	SOND_AMB_2_HUM	Status	%rH	0.0	99.9	Room probe nº 2 - humidity value
198	198	198	R/W	SOND_AMB_2_ROCIO	Status	°C	-99.9	99.9	Room probe nº 2 - dew point
199	199	199	R/W	SEL_TEMP_2_SOND_AMB_FRIO	Config.	---	0: average 1: minimal 2: maximum		Selection of temperature value with 2 ambient probes in COOLING mode
200	200	200	R/W	SEL_TEMP_2_SOND_AMB_CALOR	Config.	---	0: average 1: minimal 2: maximum		Selection of temperature value with 2 ambient probes in HEATING mode
201	201	201	R	CAUDAL_RENOVACION_MSK	Status	x10m³/h	0	9999	Renovation flow of outdoor air



Carel Addr.	Modbus record	Modbus extended	Read / Write	Variable	Parameter type	UOM	Min. value	Max. value	Description
202	202	202	R	NUM_WO_H_SPV	Status		0	9999	Work Order Number of unit (high level)
203	203	203	R	NUM_WO_L_SPV	Status		0	9999	Work Order Number of unit (low level)
204	204	204	R	T_P_BINT_C1	An. input	BAR	-99.9	99.9	Temperature or pressure indoor coil circuit 1
205	205	205	R	T_P_BINT_C2	An. input	BAR	-99.9	99.9	Temperature or pressure indoor coil circuit 2
206	206	206	R	T_P_BINT_C1_2	An. input	BAR	-99.9	99.9	Temperature or pressure indoor coil circuit 3
207	207	207	R	T_P_BINT_C2_2	An. input	BAR	-99.9	99.9	Temperature or pressure indoor coil circuit 4
----	----	208	R	TEMP_CAL_BINT_C1	An. input	°C	-99.9	99.9	Temperature calculated for the indoor coil circuit 1
----	----	209	R	TEMP_CAL_BINT_C2	An. input	°C	-99.9	99.9	Temperature calculated for the indoor coil circuit 2
----	----	210	R	TEMP_CAL_BINT_C1_2	An. input	°C	-99.9	99.9	Temperature calculated for the indoor coil circuit 3
----	----	211	R	TEMP_CAL_BINT_C2_2	An. input	°C	-99.9	99.9	Temperature calculated for the indoor coil circuit 4
----	----	212	R/W OEM	TAR_T_P_BINT_C1	Service	BAR	-9.9	9.9	Calibration of indoor coil sensor circuit 1
----	----	213	R/W OEM	TAR_T_P_BINT_C2	Service	BAR	-9.9	9.9	Calibration of indoor coil sensor circuit 2
----	----	214	R/W OEM	TAR_T_P_BINT_C1_2	Service	BAR	-9.9	9.9	Calibration of indoor coil sensor circuit 3
----	----	215	R/W OEM	TAR_T_P_BINT_C2_2	Service	BAR	-9.9	9.9	Calibration of indoor coil sensor circuit 4
----	----	216	R/W OEM	SET_C_COND_VINT	Fan	BAR	0	60.0	Indoor fan condensation control setpoint
----	----	217	R/W OEM	BANDA_C_COND_VINT	Fan	BAR	0	10.0	Indoor fan condensation control differential
----	----	218	R/W OEM	SET_C_EVAP_VINT	Fan	BAR	0	60.0	Indoor fan evaporation control setpoint
----	----	219	R/W OEM	BANDA_C_EVAP_VINT	Fan	BAR	0	10.0	Indoor fan evaporation control differential
----	----	220	R/W	OFFSET_VALV_FRIO	Regulation	°C	0	10.0	Auxiliary hot water coil offset (cool valve)
----	----	221	R/W	DIF_VALV_FRIO	Regulation	°C	0	5.0	Auxiliary hot water coil differential (cool valve)
----	----	222	R/W	SET_TEMP_EXT_CAMBIO_CALOR	Commands	°C	-99.9	99.9	Outdoor temperature setpoint for change to HEATING mode.
----	----	223	R/W	SET_TEMP_EXT_CAMBIO_FRIO	Commands	°C	-99.9	99.9	Outdoor temperature setpoint for change to COOLING mode.
----	----	224	R/W OEM	SET_TEMP_MEZ_FRIO	Config.	°C	20.0	50.0	Mixed air temperature setpoint for turning OFF the outdoor air damper in COOLING mode (summer)
----	----	225	R/W OEM	SET_TEMP_CO2_FRIO	Config.	°C	20.0	50.0	Temperature setpoint for turning OFF the outdoor air damper in COOLING mode (summer) with CO2 sensor
----	----	226	R/W OEM	SET_TEMP_EXT_DES	Defrosting	°C	0.0	50.0	Outside T setpoint to allow the defrosting by difference
----	----	227	R/W OEM	TAR_TEMP_ENTRADA_BAC	Service	°C	-9.9	9.9	Adjust of water inlet temperature of the hot water coil
----	----	228	R/W OEM	TAR_TEMP_SALIDA_BAC	Service	°C	-9.9	9.9	Adjust of water outlet temperature of the hot water coil
----	----	229	R/W OEM	SET_ANTIHIELO_AGUA_BAC	Config.	°C	-20.0	10.0	Water antifreeze setpoint of the hot water coil
----	----	230	R/W OEM	DIF_ANTIHIELO_AGUA_BAC	Config.	°C	0.0	10.0	Differential for reset of the water antifreeze of the hot water coil
----	----	231	R	SONDA_MEZCLA_TEMP	Status	°C	-99.9	99.9	Mixing probe - temperature value
----	----	232	R	SONDA_MEZCLA_HUM	Status	%rH	0.0	99.9	Mixing probe - humidity value
----	----	233	R	SONDA_MEZCLA_ROCIO	Status	°C	-99.9	99.9	Mixing probe - dew point
----	----	234	R	SONDA_IMPULSION_TEMP	Status	°C	-99.9	99.9	Supply probe - temperature value
----	----	235	R	SOND_IMPULSION_HUM	Status	%rH	0.0	99.9	Supply probe - humidity value
----	----	236	R	SONDA_IMPULSION_ROCIO	Status	°C	-99.9	99.9	Supply probe - dew point
----	----	237	R	ENTALPIA_MEZCLA_KCAL	Status	Kcal/Kg	0.0	99.9	Mixing enthalpy
----	----	238	R	ENTALPIA_IMPULSION_KCAL	Status	Kcal/Kg	0.0	99.9	Supply enthalpy
----	----	239	R	Pot_termica	Status	KW	0	3276,7	COOLING / HEATING power meter
----	----	240	R	ERR_COP	Status		0	3276,7	EER or COP value
----	----	241	R	SONDA_AMB_3_TEMP	Status	°C	-99.9	99.9	Room probe nº 3 - temperature value
----	----	242	R	SONDA_AMB_3_HUM	Status	%rH	0.0	99.9	Room probe nº 3 - humidity value
----	----	243	R	SONDA_AMB_3_ROCIO	Status	°C	-99.9	99.9	Room probe nº 3 - dew point
----	----	244	R	SONDA_AMB_4_TEMP	Status	°C	-99.9	99.9	Room probe nº 4 - temperature value
----	----	245	R	SONDA_AMB_4_HUM	Status	%rH	0.0	99.9	Room probe nº 4 - humidity value
----	----	246	R	SONDA_AMB_4_ROCIO	Status	°C	-99.9	99.9	Room probe nº 4 - dew point

6.4. Integer variables

Carel Addr.	Modbus record	Modbus extended	Read / Write	Variable	Parameter type	UOM	Min. value	Max. value	Description
1	209	5002	R/W OEM	TIPO_VENT_EXT	Configuration	---	1: centrifugal 2: radial 3: 2 speeds 4: electronic		Outdoor fan type (1 = centrifugal, 2 = axial/radial, 3 = 2 speeds, 4 = electronic)
2	210	5003	R/W	CONTROL_QUEMADOR_GAS	Commands	---	0 = burner 2nd stage 1 = only burner 2 = only burner with low outdoor temperature		Gas burner control (0 = burner 2nd stage; 1 = only burner, 2 = only burner with low outdoor temperature)
3	211	5004	R	CO2	Status	ppm	0	32767	Reading of the CO2 air quality sensor
4	212	5005	R/W	SP_CO2	Regulation	ppm	-32767	32767	CO2 air quality control setpoint
5	213	5006	R/W	DIF_CO2	Regulation	ppm	-32767	32767	CO2 air quality control differential
6	214	5007	R	Concentration_ppm_Gas_Leakag	Status	ppm	0	32767	Ppm concentration in the gas leakage detector
7	215	5008	R	Concentration_Percent_Gas_Leakag	Status	%	0	100	Percentage concentration in the gas leakage detector
8	216	5009	R/W OEM	Alarm_Setp_ppm	Alarm	ppm	0	32767	Alarm limit in ppm for gas leakage detector
9	217	5010	R/W OEM	TIME_MIN_APERTURA_ON_REC	Configuration	s	0	999	Time required with minimum opening outdoor air damper for turning ON the recovery compressor
10	218	5011	R	N_HOR_COMP1	Status	h	0	32767	Operating hours of compressor 1 circuit 1
11	219	5012	R	N_HOR_COMP2	Status	h	0	32767	Operating hours of compressor 1 circuit 2 (units 2 circ.) or compressor 3 (units 4 circ.)
12	220	5013	R	N_HOR_CR	Status	h	0	32767	Operating hours of recovery compressor
13	221	5014	R/W OEM	SET_HOR_CR	Service	h	0	32000	Operating hours limit of recovery compressor
14	222	5015	R	PR_ENT_EXTERIOR	Status	kc/kg	0	99	Integer part of outdoor enthalpy
15	223	5016	R	SEC_ENT_EXTERIOR	Status	kc/kg	0	999	Decimal part of outdoor enthalpy
16	224	5017	R	PR_ENT_INTERIOR	Status	kc/kg	0	99	Integer part of indoor enthalpy
17	225	5018	R	SEC_ENT_INTERIOR	Status	kc/kg	0	999	Decimal part of indoor enthalpy
18	226	5019	R/W OEM	TIME_RET_AL_TEMP	Alarm	s	0	999	Delay in return air temperature alarm (high/low temp.)
19	227	5020	R/W OEM	TIME_RET_AL_BP	Compressor	s	0	9999	Delay in low pressure alarm
20	228	5021	R/W	PR_ENT_DIF	Regulation	kc/kg	0	99	Integer part of difference between outdoor and indoor enthalpy
21	229	5022	R/W	SEC_ENT_DIF	Regulation	kc/kg	0	999	Decimal part of difference between outdoor and indoor enthalpy
22	230	5023	R/W	NUM_COMP_DESHUM	Regulation	---	0	NUM_COMPRESORES	Number of compressors during dehumidification
23	231	5024	R/W OEM	TIME_RET_OFF_VINT_FRIO	Fan	s	0	999	Delay in stopping the indoor fan in COOLING mode (summer)
24	232	5025	R/W OEM	TIME_RET_OFF_VINT_CALOR	Fan	s	0	999	Delay in stopping the indoor fan in HEATING mode (winter)
25	233	5026	R/W OEM	TIME_RET_ON_COMP	Fan	s	0	999	Delay in starting the compressors after starting the indoor fan
26	234	5027	R/W OEM	TIME_RET_AL_TERM_VENT_INT	Alarm	s	0	999	Delay in interlock alarm
27	235	5028	R/W OEM	TIME_MIN_OFF_COMP	Compressor	s	0	9999	Minimum stop time for the compressors
28	236	5029	R/W OEM	NEW_PASS_UT	Safety	---	0	9999	New USER password
29	237	5030	R/W OEM	NEW_PASS_ASS	Safety	---	0	9999	New MAINTENANCE password
30	238	5031	R/W OEM	NEW_PASS_COS	Safety	---	0	9999	New MANUFACTURER password
31	239	5032	R/W OEM	TIME_MIN_ON_ON_COMP	Compressor	s	0	9999	Minimum time between start-ups of the same compressor
32	240	5033	R/W OEM	TIME_MIN_ON_ON_COMP_DIST	Compressor	s	0	9999	Time between start-ups of different compressors
33	241	5034	R/W OEM	TIME_MIN_ON_COMP	Compressor	s	0	9999	Minimum start-up time of a compressor
34	242	5035	R/W OEM	TIME_RET_INICIO_DES	Defrosting	s	0	999	Delay period before start of defrosting procedure
35	243	5036	R/W OEM	TIME_MAX_DUR_DES	Defrosting	min	0	999	Maximum defrosting time
36	244	5037	R/W	SET_RENOVACION	Regulation	%	0	99	% of outdoor air for renewal



Communications electronic control

Carel Addr.	Modbus record	Modbus extended	Read / Write	Variable	Parameter type	UOM	Min. value	Max. value	Description
37	245	5038	R/W OEM	SET_HOR_ON_EQUIPO	Service	h	0	32000	Operating hours limit of the unit
38	246	5039	R/W OEM	SET_HOR_COMP1	Service	h	0	32000	Operating hours limit of compressor 1 circuit 1
39	247	5040	R/W OEM	SET_HOR_COMP2	Service	h	0	32000	Operating hours limit of compressor 1 circuit 2 (units 2 circ.) or compressor 3 (units 4 circ.)
40	248	5041	R/W OEM	TIME_ENTRE_DES_DIF	Defrosting	min	0	99	Minimum time between defrosting of the same circuit by difference with outdoor temperature
41	249	5042	R/W OEM	NUM_RES	Configuration	---	0: ----- 1: 1 elec. heater 2: 2 elec. heater 3: 2 elec. heater (3 st.) 4: proportional	Number of electrical heater stages	
42	250	5043	R/W OEM	TIME_INTEGRACION	Fan	s	0	999	Integral time for proportional + integral control (P+I)
43	251	5044	R/W	TIPO_REFRIGERANTE	Configuration	---	0: R22 1: R134A 2: R404A 3: R407C 4: R410A	Type of refrigerant	
44	252	5045	R	N_ARR_CR_H	Status	---	0	99	Number of starts of recovery compressor (high level)
45	253	5046	R	N_ARR_CR_L	Status	---	0	9999	Number of starts of recovery compressor (low level)
46	254	5047	R/W	TIPO_SOND_AMB	Configuration	---	1: 1 probe RS485 2: 2 probes RS485 3: probe pLAN 4: 1 probe NTC	Type of ambient probe	
47	255	5048	R	MINUTO	Status	min	0	99	Clock setting: minute
48	256	5049	R	HORA	Status	h	0	99	Clock setting: hour
49	257	5050	R	DIA	Status	---	0	99	Clock setting: day
50	258	5051	R	MES	Status	---	0	99	Clock setting: month
51	259	5052	R	AGNO	Status	---	0	99	Clock setting: year
52	260	5053	R	DIA_SEMANA	Status	---	0	9	Clock setting: weekday
53	261	5054	R	N_HOR_COMP1_2	Status	---	0	32767	Operating hours of compressor 2 circ. 1 (units 2 circ.) or compressor 2 (units 4 circ.)
54	262	5055	R/W OEM	TIPO_TEMP_EXT	Configuration	---	0: no 1: actual 2: pLAN	Type of outdoor air temperature sensor	
55	263	5056	R/W OEM	TIPO_Probe_HUM_EXT	Configuration	---	0: no 1: actual 2: pLAN	Type of outdoor air relative humidity sensor	
56	264	5057	R/W OEM	TIPO_Probe_HUM_INT	Configuration	---	0: no 1: actual 2: virtual 3: pLAN 4: RS485	Type of indoor relative humidity sensor	
57	265	5058	R/W OEM	TIPO_RELOJ	Configuration	---	0: no 1: actual 2: pLAN	Type of timer board	
58	266	5059	R/W OEM	TIME_PANT	Regulation	s	0	999	Automatic OFF time for pGD console display lighting
59	267	5060	R/W OEM	SEL_FRIO_CALOR	Configuration	---	0: panel 1: remote 2: automatic	COOLING/HEATING mode selection	
60	268	5061	R/W OEM	NUM_COMP_CIRC	Configuration	---	0: --- 1: 1 compr./ 1 circuit 2: 2 compr./ 1 circuit 3: 2 compr./ 2 circuits 4: 2 compr. + 1 part. 5: 2 compr. (3 stages) 6: 4 compr./ 2 circuits 7: 4 compr./ 4 circuits	Number of compressors	
61	269	5062	R/W OEM	NUM_RES_DES	Configuration	---	0	NUM_RES	Number of electrical heater stages during defrosting
62	270	5063	R	N_HOR_ON_EQUIPO	Status	---	0	32767	Operating hours of the unit

Carel Addr.	Modbus record	Modbus extended	Read/Write	Variable	Parameter type	UOM	Min. value	Max. value	Description
63	271	5064	R/W	LANGUAGE	Regulation	---	0: spanish 1: frech 2: english 3: italian 4: turc 5: german		Selection of the language of the software installed on the µPC MEDIUM board
64	272	5065	R/W OEM	TIME_MIN_DUR_DES	Defrosting	min	0	999	Minimum defrosting time
65	273	5066	R/W OEM	TIME_AL_VIRT	Alarm	s	0	9999	Delay of alarm for disconnection of pLAN sensor
66	274	5067	R	NUM_AL	Status	---	0	99	Number of active alarms
67	275	5068	R/W OEM	SET_HOR_COMP1_2	Service	h	0	32000	Operating hours limit of compressor 2 circ. 1 (units 2 circ.) or compressor 2 (units 4 circ.)
68	276	5069	R/W OEM	MIN_APERTURA_ON_REC	Configuration	%	0	99	% opening of damper to enable recovery compressor to be ON
69	277	5070	R	N_HOR_COMP2_2	Status	h	0	32767	Operating hours of compressor 2 circ. 2 (units 2 circ.) or compressor 4 (units 4 circ.)
70	278	5071	R/W OEM	SET_HOR_COMP2_2	Service	h	0	32000	Operating hours limit of compressor 2 circ. 2 (units 2 circ.) or compressor 4 (units 4 circ.)
71	279	5072	R/W	TIPO_ARR	RTC	---	0: ON-OFF 1: only setpoint change 2: ON-OFF + limit setpoint 3: Manual 4: 3 setpoint + unit ON/OFF 5: Forced		Start-up type for the time schedule
72	280	5073	R/W OEM	TIPO_BLOQ_COMP_FRIO_FC	Compressor	---	0: no 1: delta amb. T - outd. T 2: outdoor set		Disable the compressors with free-cooling in COOLING mode (summer)
73	281	5074	R/W	TIME_F_MAN	RTC	s	1	999	Minimum running time with forced start-up (h)
74	282	5075	R/W	H_ARR_1A	RTC	h	0	23	Start-up hour slot 1 programme 1
75	283	5076	R/W	M_ARR_1A	RTC	min	0	59	Start-up minute slot 1 programme 1
76	284	5077	R/W	H_PAR_1A	RTC	h	0	23	Stop hour slot 1 programme 1
77	285	5078	R/W	M_PAR_1A	RTC	min	0	59	Stop minute slot 1 programme 1
78	286	5079	R/W	H_ARR_1B	RTC	h	0	23	Start-up hour slot 2 programme 1
79	287	5080	R/W	M_ARR_1B	RTC	min	0	59	Start-up minute slot 2 programme 1
80	288	5081	R/W	H_PAR_1B	RTC	h	0	23	Stop hour slot 2 programme 1
81	289	5082	R/W	M_PAR_1B	RTC	min	0	59	Stop minute slot 2 programme 1
82	290	5083	R/W	H_ARR_1C	RTC	h	0	23	Start-up hour slot 3 programme 1
83	291	5084	R/W	M_ARR_1C	RTC	min	0	59	Start-up minute slot 3 programme 1
84	292	5085	R/W	H_PAR_1C	RTC	h	0	23	Stop hour slot 3 programme 1
85	293	5086	R/W	M_PAR_1C	RTC	min	0	59	Stop minute slot 3 programme 1
86	294	5087	R/W	H_ARR_2A	RTC	h	0	23	Start-up hour slot 1 programme 2
87	295	5088	R/W	M_ARR_2A	RTC	min	0	59	Start-up minute slot 1 programme 2
88	296	5089	R/W	H_PAR_2A	RTC	h	0	23	Stop hour slot 1 programme 2
89	297	5090	R/W	M_PAR_2A	RTC	min	0	59	Stop minute slot 1 programme 2
90	298	5091	R/W	H_ARR_2B	RTC	h	0	23	Start-up hour slot 2 programme 2
91	299	5092	R/W	M_ARR_2B	RTC	min	0	59	Start-up minute slot 2 programme 2
92	300	5093	R/W	H_PAR_2B	RTC	h	0	23	Stop hour slot 2 programme 2
93	301	5094	R/W	M_PAR_2B	RTC	min	0	59	Stop minute slot 2 programme 2
94	302	5095	R/W	H_ARR_2C	RTC	h	0	23	Start-up hour slot 3 programme 2
95	303	5096	R/W	M_ARR_2C	RTC	min	0	59	Start-up minute slot 3 programme 2
96	304	5097	R/W	H_PAR_2C	RTC	h	0	23	Stop hour slot 3 programme 2
97	305	5098	R/W	M_PAR_2C	RTC	min	0	59	Stop minute slot 3 programme 2
98	306	5099	R/W	H_ARR_3A	RTC	h	0	23	Start-up hour slot 1 programme 3
99	307	5100	R/W	M_ARR_3A	RTC	min	0	59	Start-up minute slot 1 programme 3

Carel Addr.	Modbus record	Modbus extended	Read / Write	Variable	Parameter type	UOM	Min. value	Max. value	Description
100	308	5101	R/W	H_PAR_3A	RTC	h	0	23	Stop hour slot 1 programme 3
101	309	5102	R/W	M_PAR_3A	RTC	min	0	59	Stop minute slot 1 programme 3
102	310	5103	R/W	H_ARR_3B	RTC	h	0	23	Start-up hour slot 2 programme 3
103	311	5104	R/W	M_ARR_3B	RTC	min	0	59	Start-up minute slot 2 programme 3
104	312	5105	R/W	H_PAR_3B	RTC	h	0	23	Stop hour slot 2 programme 3
105	313	5106	R/W	M_PAR_3B	RTC	min	0	59	Stop minute slot 2 programme 3
106	314	5107	R/W	H_ARR_3C	RTC	h	0	23	Start-up hour slot 3 programme 3
107	315	5108	R/W	M_ARR_3C	RTC	min	0	59	Start-up minute slot 3 programme 3
108	316	5109	R/W	H_PAR_3C	RTC	h	0	23	Stop hour slot 3 programme 3
109	317	5110	R/W	M_PAR_3C	RTC	min	0	59	Stop minute slot 3 programme 3
110	318	5111	R/W	LUN_A	RTC	---	0	3	Selection of the schedule programme for Monday
111	319	5112	R/W	MAR_A	RTC	---	0	3	Selection of the schedule programme for Tuesday
112	320	5113	R/W	MIE_A	RTC	---	0	3	Selection of the schedule programme for Wednesday
113	321	5114	R/W	JUE_A	RTC	---	0	3	Selection of the schedule programme for Thursday
114	322	5115	R/W	VIE_A	RTC	---	0	3	Selection of the schedule programme for Friday
115	323	5116	R/W	SAB_A	RTC	---	0	3	Selection of the schedule programme for Saturday
116	324	5117	R/W	DOM_A	RTC	---	0	3	Selection of the schedule programme for Sunday
117	325	5118	R/W OEM	CONF_OUT07	Configuration	---	0: Humidifier 1: Pump in HWC circuit 2: Recovery compressor 3: Alarm 4: inactive 5: Rotary recovery oper.		Type of element connected in digital outlet 11
118	326	5119	R/W OEM	TIPO_FREECOOLING	Configuration	---	0: thermal 1: enthalpic 2: thermoenthalpic		Type of free-cooling: thermal, enthalpic or thermal enthalpic
119	327	5120	R/W	_NEW_HOUR	RTC	h	0	23	Clock setting: new hour
120	328	5121	R/W	_NEW_MINUTE	RTC	min	0	59	Clock setting: new minutes
121	329	5122	R/W	_NEW_DAY	RTC	---	1	31	Clock setting: new day
122	330	5123	R/W	_NEW_MONTH	RTC	---	1	12	Clock setting: new month
123	331	5124	R/W	_NEW_YEAR	RTC	---	0	99	Clock setting: new year
124	332	5125	R	RENOVACION_CAL	Status	%	0	99	Calculation of % air renewal depending on mixing temperature
125	333	5126	R	CAL_APER_RENOV_2	Status	%	0	99	Calculation of % damper opening depending on renewal
126	334	5127	R	SET_RENOVACION_CAL	Status	%	0	99	Calculation of outdoor air percentage allowed for renewal
127	335	5128	R/W OEM	TIPO_Probe_RENOVACION	Configuration	---	0: None 1: Mixed air temperature 2: Actual air quality probe 3: pLAN air quality probe		Type of sensor for renewal
128	336	5129	R/W	DESCONEXION_NUM_COMPRESORES	Commands	---	0	NUM_ETAPAS_COMPRESOR	Number of stages of compressors to disconnect
129	337	5130	R/W	DESCONEXION_NUM_RESISTENCIAS	Commands	---	0	NUM_RES	Number of stages of electrical heaters to disconnect
130	338	5131	R	NUM_ETAPAS_Compressor	Status	---	0	4	Number of compressor stages
131	339	5132	R/W	MAX_APERTURA_COMPUERTA	Regulation	%	0	100	Maximum opening of the outdoor air damper
132	340	5133	R/W OEM	TIME_INT_C_EVAP_VEXT	Fan	s	0	999	Integral time for P+I control for outdoor unit evaporation control
133	341	5134	R/W OEM	TIME_INT_C_COND_VEXT	Fan	s	0	999	Integral time for P+I control for outdoor unit condensation control
134	342	5135	R	NUM_WO_SPV	Estado	---	0	9999	Work Order Number of unit (WO) (Integer part)
135	343	5136	R/W	NUM_WO_SPV	Estado	---	0	9999	Work Order Number of unit (WO) (Decimal part)

Carel Addr.	Modbus record	Modbus extended	Read/Write	Variable	Parameter type	UOM	Min. value	Max. value	Description
136	344	5137	R	N_HOR_VENT	Status	h	0	32767	Operating hours of the indoor fan
137	345	5138	R	N_HOR_RES1	Status	h	0	32767	Operating hours of electrical heater No. 1
138	346	5139	R	N_HOR_RES2	Status	h	0	32767	Operating hours of electrical heater No. 2
139	347	5140	R	N_ARR_V_INT_H	Status	---	0	99	Number of starts of the indoor fan (high level)
140	348	5141	R	N_ARR_V_INT_L	Status	---	0	9999	Number of starts of the indoor fan (low level)
141	349	5142	R	N_ARR_COMP1_H	Status	---	0	99	Number of starts of compressor 1 circuit 1 (high level)
142	350	5143	R	N_ARR_COMP1_L	Status	---	0	9999	Number of starts of compressor 1 circuit 1 (low level)
143	351	5144	R	N_ARR_COMP1_2_H	Status	---	0	99	Number of starts of compressor 2 circuit 1 (units 2 circ.) or compressor 2 (units 4 circ.) (high level)
144	352	5145	R	N_ARR_COMP1_2_L	Status	---	0	9999	Number of starts of compressor 2 circuit 1 (units 2 circ.) or compressor 2 (units 4 circ.) (low level)
145	353	5146	R	N_ARR_COMP2_H	Status	---	0	99	Number of starts of compressor 1 circuit 2 (units 2 circ.) or compressor 3 (units 4 circ.) (high level)
146	354	5147	R	N_ARR_COMP2_L	Status	---	0	9999	Number of starts of compressor 1 circuit 2 (units 2 circ.) or compressor 3 (units 4 circ.) (low level)
147	355	5148	R	N_ARR_COMP2_2_H	Status	---	0	99	Number of starts of compressor 2 circuit 2 (units 2 circ.) or compressor 4 (units 4 circ.) (high level)
148	356	5149	R	N_ARR_COMP2_2_L	Status	---	0	9999	Number of starts of compressor 2 circuit 2 (units 2 circ.) or compressor 4 (units 4 circ.) (low level)
149	357	5150	R	N_ARR_RES1_H	Status	---	0	99	Number of starts of elec.I heater stage No. 1 (high level)
150	358	5151	R	N_ARR_RES1_L	Status	---	0	9999	Number of starts of elec. heater stage No. 1 (low level)
151	359	5152	R	N_ARR_RES2_H	Status	---	0	99	Number of starts of ele. heater stage No. 2 (high level)
152	360	5153	R	N_ARR_RES2_L	Status	---	0	9999	Number of starts of elec. heater stage No. 2 (low level)
153	361	5154	R	N_DES_C1_H	Status	---	0	99	Number of defrosting procedures for circuit 1 (high level)
154	362	5155	R	N_DES_C1_L	Status	---	0	9999	Number of defrosting procedures for circuit 1 (low level)
155	363	5156	R	N_DES_C1_2_H	Status	---	0	99	Number of defrosting procedures for circuit 3 (high level)
156	364	5157	R	N_DES_C1_2_L	Status	---	0	9999	Number of defrosting procedures for circuit 3 (low level)
157	365	5158	R	N_DES_C2_H	Status	---	0	99	Number of defrosting procedures for circuit 2 (high level)
158	366	5159	R	N_DES_C2_L	Status	---	0	9999	Number of defrosting procedures for circuit 2 (low level)
159	367	5160	R	N_DES_C2_2_H	Status	---	0	99	Number of defrosting procedures for circuit 4 (high level)
160	368	5161	R	N_DES_C2_2_L	Status	---	0	9999	Number of defrosting procedures for circuit 4 (low level)
161	369	5162	R	N_SEG_ULT_DES_C1	Status	---	0	999	Number of seconds since the last defrosting procedure for circuit 1
162	370	5163	R	N_SEG_ULT_DES_C1_2	Status	---	0	999	Number of seconds since the last defrosting procedure for circuit 3
163	371	5164	R	N_SEG_ULT_DES_C2	Status	---	0	999	Number of seconds since the last defrosting procedure for circuit 2
164	372	5165	R	N_SEG_ULT_DES_C2_2	Status	---	0	999	Number of seconds since the last defrosting procedure for circuit 4
165	373	5166	R/W	MIN_APERTURA_COMPUERTA	Regulation	%	0	100	Minimum opening of the outdoor air damper
166	374	5167	R/W	TIME_ON_AUTOSTART	Regulation	s	5	999	Automatic start-up time after blocking
167	375	5168	R	Voltage_L1_L2_L_SPV	Status	V	0	9999	Voltage between lines 1 and 2
168	376	5169	R	Voltage_L2_L3_L_SPV	Status	V	0	9999	Voltage between lines 2 and 3
169	377	5170	R	Voltage_L3_L1_L_SPV	Status	V	0	9999	Voltage between lines 3 and 1
170	378	5171	R	Voltage_1_L_SPV	Status	V	0	9999	Voltage line 1
171	379	5172	R	Voltage_2_L_SPV	Status	V	0	9999	Voltage line 2
172	380	5173	R	Voltage_3_L_SPV	Status	V	0	9999	Voltage line 3
173	381	5174	R	Power_Factor_MSK_BMS_GAVAZZI	Status	---	0	32	Power factor
174	382	5175	R	Apparent_Energy_H_SPV	Status	kVArh	0	9999	Reactive energy (Integer part)
175	383	5176	R	Apparent_Energy_L_SPV	Status	kVArh	0	9999	Reactive energy (Decimal part)
176	384	5177	R	Energy_H_SPV	Status	KWh	0	9999	Energy (Integer part)
177	385	5178	R	Energy_L_SPV	Status	KWh	0	9999	Energy (Decimal part)
178	386	5179	R	CT_L_SPV	Status	---	0	9999	Multiplier of the current transformer

Carel Addr.	Modbus record	Modbus extended	Read / Write	Variable	Parameter type	UOM	Min. value	Max. value	Description
179	387	5180	R	System_Type	Status	---	0: 3p 1: 3P.n 2: 2P 3: 1P 4: 3P.A		Type of power supply
180	388	5181	R	Hourmeter_H_SPV	Status	h	0	9999	Hours of electrical energy meter (High part)
181	389	5182	R	Hourmeter_L_SPV	Status	h	0	9999	Hours of electrical energy meter (Low part)
182	390	5183	R/W OEM	TIPO_EQUIPO	Configurat.	---	0: air-air 1: eau-air		Selection of the type of unit (0=air-air, 1=water-air)
183	391	5184	R/W OEM	TIME_RET_AL_CAUDAL	Alarm	s	0	120	Flow switch time delay
184	392	5185	R/W OEM	MIN_AOUT_VENT_EXT	Configurat.	%	0	100	Minimum analogue output for outdoor fan
185	393	5186	R/W OEM	TIME_ON_VEXT_INI_DES	Defrosting	s	0	120	Outdoor fan connection time at the start of defrosting
186	394	5187	R/W OEM	TIME_VINT_ON_ANTIESTRATIF	Fan	min	0	999	Anti-stratification: indoor fan ON time
187	395	5188	R/W OEM	TIME_VINT_OFF_ANTIESTRATIF	Fan	min	0	999	Anti-stratification: indoor fan OFF time
188	396	5189	R/W OEM	PORCEN_TEMP_OFF_DESH	Configurat.	%	0	100	% return air T with regard to the setpoint for disconnection of compressor in dehumidification
189	397	5190	R/W OEM	PORCEN_TEMP_ON_DESH	Configurat.	%	0	100	% return air T with regard to the setpoint for the connection of compressor in dehumidification
190	398	5191	R/W OEM	HAB_HUMIDIFICA	Configurat.	---	0: no 1: on/off 2: proportional		Enabling humidification function (no, on-off, proportional)
191	399	5192	R	INFO_EQUIPO_1	Status	---	0: air-air cooling only 1: air-air heat pump 2: water-air cooling only 3: water-air heat pump		Unit information: air-air, water-air, cooling only, reversible
192	400	5193	R	INFO_EQUIPO_2	Status	---	0: ----- 1: 1 comp/1 circ 2: 2 comp/1 circ 3: 2 comp/2 circ 4: 2 comp.+1 par. 5: 2 comp.(3et.) 6: 4 comp/2 circ 7: 4 comp/4 circ 10: comp. rec. 11: 1 comp/1 circ + c.rec. 12: 2 comp/1 circ + c.rec. 13: 2 comp/2 circ + c.rec. 14: 2 comp.+1 par. + c.rec. 15: 2 comp.(3et.) + c.rec. 16: 4 comp/2 circ + c.rec. 17: 4 comp/4 circ + c.rec.		Unit information: compressors-circuits (0, 1c, 2c-1c, 2c-2c, 2c+p, 2c 3st, 4c tand, 4c-4c) + recovery
193	401	5194	R	INFO_EQUIPO_3	Status	---	0: --- 1: electrical heaters 2: gas burner 3: el. heaters.+ gas burner 4: HWC 5: HWC + el. heaters 6: HWC + gas burner 7: HWC+ gas burner + heaters		Unit information: electrical heaters, gas burner, hot water coil
194	402	5195	R/W OEM	TIME_CAL	Service	s	0	99	Damper opening calculation time
195	403	5196	R/W OEM	V_CAL	Service	%	0	99	% damper opening in calculation time
196	404	5197	R/W OEM	TIPO_VENT_INT	Configurat.		1: centrifuge 2: axial / radial 3: radial plug-fan 4: centrifuge + VFD		Type of indoor fan
197	405	5198	R/W OEM	SET_CAUDAL_VINT_VENTILACION	Service	x 10m³/h	CAUDAL_VINT_NOMINAL_MIN	CAUDAL_VINT_NOMINAL_MAX	Flow setpoint in ventilation with the plug-fan indoor fan
198	406	5199	R	CAUDAL_VINT_MEDIDO_AJUSTE	Status	x 10m³/h	0	9999	Flow rate measured with plug-fan indoor fan

Carel Addr.	Modbus record	Modbus extended	Read / Write	Variable	Parameter type	UOM	Min. value	Max. value	Description
199	407	5200	R	actual_speed_msk	Status	rpm	0	9999	Speed measured with plug-fan indoor fan
200	408	5201	R/W OEM	SET_CAUDAL_VINT_FRIO	Service	x 10m³/h	CAUDAL_VINT_NOMINAL_MIN	CAUDAL_VINT_NOMINAL_MAX	Flow rate setpoint in cooling mode with plug-fan indoor fan
201	409	5202	R/W OEM	SET_CAUDAL_VINT_CALOR	Service	x 10m³/h	CAUDAL_VINT_NOMINAL_MIN	CAUDAL_VINT_NOMINAL_MAX	Flow rate setpoint in heating mode with plug-fan indoor fan
202	410	5203	R/W OEM	TIPO_VENT_RET	Configuration		0: --- 1: centrifuge 2: radial 3: radial plug-fan 4: centrifuge + VFD		Type of return fan
203	411	5204	R/W OEM	SET_CAUDAL_VRET_VENTILACION	Service	x 10m³/h	CAUDAL_VRET_NOMINAL_MIN	CAUDAL_VRET_NOMINAL_MAX	Flow rate setpoint in ventilation mode with return plug-fan
204	412	5205	R	CAUDAL_VRET_MEDIDO_AJUSTE	Status	x 10m³/h	0	9999	Flow rate measured with return plug-fan
205	413	5206	R	actual_speed_msk_FAN2	Status	rpm	0	9999	Speed measured with return plug-fan
206	414	5207	R/W OEM	SET_CAUDAL_VRET_FRIO	Service	x 10m³/h	CAUDAL_VRET_NOMINAL_MIN	CAUDAL_VRET_NOMINAL_MAX	Flow rate setpoint in cooling mode with return plug-fan
207	415	5208	R/W OEM	SET_CAUDAL_VRET_CALOR	Service	x 10m³/h	CAUDAL_VRET_NOMINAL_MIN	CAUDAL_VRET_NOMINAL_MAX	Flow rate setpoint in heating mode with return plug-fan
----	----	5209	R/W	MAX_APERTURA_COMPUERTA_FREE	Regulation	%	0	100	Maximum opening of the outdoor air damper with freecooling or freeheating
----	----	5210	R/W OEM	CONF_OUT08	Configuration	---	0: Alarm 1: Pump of HWC circuit		Type of element connected in digital outlet 08
----	----	5211	R/W OEM	TIME_RET_OFF_BOMBA_BAC	Configuration	s	0	999	Minimum opening of heat valve with low outdoor temperature and unit ON.
----	----	5212	R/W OEM	MIN_APERTURA_VALV_CALOR	Configuration	%	0	100	Delay time to stop of the H.W.C. pump
----	----	5213	R	N_HOR_VALV_CALOR	Status	h	0	32767	Operating hours of the hot valve
----	----	5214	R	N_HOR_FREEC_FREEH	Status	h	0	32767	Operating hours of freecooling or freeheating
----	----	5215	R	N_HOR_REC_ROTATIVO	Status	h	0	32767	Operating hours of wheel recuperator
----	----	5216	R/W OEM	TAR_CO2	Service	ppm	-9999	9999	Air quality probe set
----	----	5217	R/W OEM	TIME_RET_ON_VINT	Fan	s	0	999	Indoor fan start delay with unit "ON"
----	----	5218	R/W OEM	CONTROL_TCO_Probe	Configuration	---	0: TCO 1: Ambient 2: Return		Selection of the control probe with TCO thermostat
----	----	5219	R/W OEM	CONF_OUT01_MOD_N8	Configuration	---	0: humidifier 1: pump in HWC circuit 2: recovery compressor 3: alarm 4: --- 5: rotary recovery oper. 6: -----		Digital output configuration OUT01 of PCOE module n.8
----	----	5220	R/W OEM	CONF_OUT04_MOD_N8	Configuration	---	0: humidifier 1: pump in HWC circuit 2: recovery compressor 3: alarm 4: --- 5: rotary recovery oper. 6: -----		Digital output configuration OUT04 of PCOE module n.8
----	----	5221	R	CO2_FISICA_zona2	Status	ppm	0	32767	Reading of the CO2 air quality sensor of the zone 2
----	----	5222	R/W OEM	TAR_CO2_zona2	Service	ppm	-9999	9999	Air quality probe set of the zone 2
----	----	5223	R/W OEM	Power_factor_setpoint	Service	---	0	32	Power factor setpoint

7. LONWORKS® SUPERVISORY VARIABLES

The LONWORKS serial card will be written to in the factory, by default, with the variables indicated in the following table. It is possible to change these variables, but a maximum of 59 variables can be written.

Tipo	Index	Descripción	Name NV	Type NV	Direcc.
Analógica	1	Return air temperature	nvoRoomTemp	105	Output
Analógica	2	Outdoor air temperature	nvoOutsideTemp	105	Output
Analógica	3	Defrosting temperature of circuit No. 1	nvoDesTemp1	105	Output
Analógica	4	Defrosting temperature of circuit No. 2	nvoDesTemp2	105	Output
Analógica	5	Relative return humidity	nvoRoomHR	81	Output
Analógica	6	Outdoor air relative humidity	nvoOutsideHR	81	Output
Analógica	7	Outlet temperature	nvoImpTemp	105	Output
Analógica	10	Outdoor air damper outlet	nvoFcoolDamp	105	Output
Analógica	11	Heat valve output (auxiliary water coil)	nvoV3VPos	105	Output
Analógica	15	Return air temperature setpoint in summer	nviSetTempCool	105	Input
Analógica	15	Return air temperature setpoint in summer	nvoSetTempCool	105	Output
Analógica	16	Return air temperature setpoint in winter	nviSetTempHeat	105	Input
Analógica	16	Return air temperature setpoint in winter	nvoSetTempHeat	105	Output
Analógica	58	Outdoor control setpoint in winter for daily phase	nviSetPrgExtHeat	105	Input
Analógica	58	Outdoor control setpoint in winter for daily phase	nvoSetPrgExtHeat	105	Output
Analógica	59	Outdoor control setpoint in summer for daily phase	nviSetPrgExtCool	105	Input
Analógica	59	Outdoor control setpoint in summer for daily phase	nvoSetPrgExtCool	105	Output
Analógica	60	Indoor control setpoint in winter for daily phase	nviSetPrgIntHeat	105	Input
Analógica	60	Indoor control setpoint in winter for daily phase	nvoSetPrgIntHeat	105	Output
Analógica	61	Indoor control setpoint in summer for daily phase	nviSetPrgIntCool	105	Input
Analógica	61	Indoor control setpoint in summer for daily phase	nvoSetPrgIntCool	105	Output
Entera	10	Operating hours of compressor No. 1	nvoHourComp1	8	Output
Entera	11	Operating hours of compressor No. 2	nvoHourComp2	8	Output
Entera	62	Machine operating hours	nvoHourMaq	8	Output
Digital	8	Remote On/Off signal	nvoOnOffRem	95	Output
Digital	15	Indoor fan	nvoOnSupFan	95	Output
Digital	16	Compressor contact 1	nvoOnComp1	95	Output
Digital	17	Compressor contact 2	nvoOnComp2	95	Output
Digital	18	Cycle reversing valve 1	nvoOnV4v1	95	Output
Digital	19	Cycle reversing valve 2	nvoOnV4v2	95	Output
Digital	20	Heater contact 1	nvoOnRes1	95	Output
Digital	21	Heater contact 2	nvoOnRes2	95	Output
Digital	23	Outdoor fan 1	nvoOnFanExt1	95	Output
Digital	24	Outdoor fan 2	nvoOnFanExt2	95	Output
Digital	26	General alarm	nvoAlrGen	95	Output
Digital	27	Thermal 1	nvoAlrTermC1	95	Output
Digital	28	Thermal 2	nvoAlrTermC2	95	Output
Digital	29	High pressure 1	nvoAlrHPC1	95	Output
Digital	30	High pressure 2	nvoAlrHPC2	95	Output
Digital	31	Anti-freeze	nvoAlrIce	95	Output
Digital	32	Damaged EPROM	novAlrEprom	95	Output
Digital	33	Broken or disconnected clock	novAlrTime	95	Output
Digital	34	Overly high return air temperature	nvoAlrRoomHT	95	Output
Digital	35	Overly low return air temperature	nvoAlrRoomLT	95	Output
Digital	36	Maintenance of compr. 1	nvoAlrMantC1	95	Output
Digital	37	Maintenance of compr. 2	nvoAlrMantC2	95	Output
Digital	38	Low pressure 1	nvoAlrLPC1	95	Output
Digital	39	Low pressure 2	nvoAlrLPC2	95	Output
Digital	40	Inter-blocking	nvoAlrTermFan	95	Output
Digital	41	Defrosting 1	nvoAlrDes1	95	Output
Digital	42	Defrosting 2	nvoAlrDes2	95	Output
Digital	43	Clogged filter	nvoAlrDirtFilt	95	Output
Digital	44	Thermal heater	nvoAlrTermRes	95	Output
Digital	61	Enable schedule phase	nviHabProg	95	Input
Digital	61	Enable schedule phase	nvoHabProg	95	Output
Digital	65	Unit off / on	nviOnOff	95	Input
Digital	66	Selection of winter/summer mode	nviHeatCool	95	Input
Digital	66	Selection of winter/summer mode	nvoHeatCool	95	Output
Digital	74	Machine state view (off/on)	nvoOnOff	95	Output

