

ENERGY OPTIMISATION

HEAT PUMP & GAS BOILER



# AQUACIAT2 HYBRID

- Cooling and heating capacities of 45 to 85 kW

COMFORT • AIR QUALITY

THE COMPACT  
DUAL-ENERGY  
SOLUTION





# AQUACIAT2<sup>HYBRID</sup>

## The compact dual-energy solution

The AQUACIAT2<sup>HYBRID</sup> offers the combined advantages of a reversible air-to-water heat pump and a condensation gas boiler. A wide range of 45 to 85 kW models to meet all cooling and heating requirements in new or refurbished tertiary buildings.

### The combined benefits of two technologies

The highly compact, dual-energy Aquaciat2<sup>HYBRID</sup> is a “fully outdoor” solution which is easy to install and does not require a machine room or gas boiler room in the building.

These machines guarantee heating, either thermodynamically or with a gas boiler according to a primary energy ruling or the scenario chosen by the system user in terms of managing gas or electricity energy.

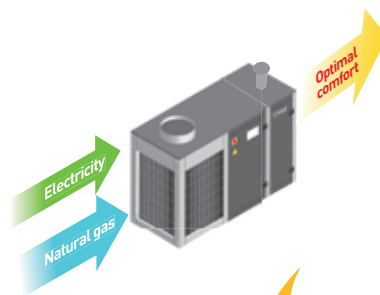

### The control system adapts to provide year-round efficiency

Both in summer and in winter, the Aquaciat2<sup>HYBRID</sup> manages the automatic operation of the installation and an outdoor temperature sensor allows the CONNECT2 controller to switch between Heating and Cooling modes.

In heating mode, based on the outdoor temperature, the same controller autonomously manages the switchover between thermodynamic operation with a heat pump and the use of the natural-gas boiler.

It automatically manages the optimum choice between gas and electricity based on a preset outdoor temperature switching value, for which the minimum COP value from the heat pump remains above the conversion factor for converting electricity into primary energy, which is fixed at 2.58 in France.



### Wide range of power levels

There are eight proposed hybrid machine combinations, coupled with three boilers (45 to 85 kW), to meet the heating or cooling requirements for new or existing 500 to 1500 m<sup>2</sup> buildings in the tertiary sector.

HEATING C	47 kW	62 kW	83 kW
	47 kW	47 kW 53 kW 62 kW	47 kW 53 kW 62 kW 75 kW
COOLING C			



# AQUACIAT2<sup>HYBRID</sup>

A new way of prioritising energy performance

**THE AQUACIAT2<sup>HYBRID</sup>** has several performance-related objectives resulting, on the one hand, from new thermal regulations, and on the other, from future constraints linked to the production and distribution of electricity (Smartgrid).

## CHOOSE THE BEST ENERGY PERFORMANCE Compliance with thermal regulations

To improve the share of renewable energy in the tertiary sector, thanks to a heat pump that functions in outdoor temperatures of down to approximately 0°C, with a coefficient of performance greater than 2.58 (equivalent to the conversion factor for converting electricity into primary energy), and with a gas boiler that provides backup for the lower temperatures.

Controlling primary energy ensures the most suitable energy source is selected, whatever the outdoor temperature.

The hybrid heat pump therefore provides three operating possibilities in heating mode according to the following scenario:

PERFORMANCE & POWER		TECHNOLOGY USED
HEAT PUMP COP ≥ 2.58	HEAT PUMP P ≥ P DEMAND	HEAT PUMP ONLY
	HEAT PUMP P < P DEMAND	HEAT PUMP & BOILER
HEAT PUMP COP < 2.58		BOILER ONLY

The Aquaciat2<sup>HYBRID</sup> also offers an energy metering function: accumulated power consumption monitoring, instantaneous power, current, etc.

## ELIMINATION OF ELECTRICAL CONSUMPTION PEAKS The Smart Grid solution

Offering a unit that is capable of supplying exactly the same heating capacity to the SMART GRID electricity networks, regardless of the energy used – gas or electricity.

In fact, the Aquaciat2<sup>HYBRID</sup> can be switched over to the gas boiler at any time with a simple outer contact, and instantly provides a significant reduction in the electrical power consumed during peak loads in the winter, without causing discomfort to users.

The gas boiler is started up as soon as the maximum electrical power measured by the unit's controller is reached, or as soon as an external signal confirming that the electricity consumption threshold has been reached is received from the building's centralised management system.

### Operating principle of Aquaciat2<sup>HYBRID</sup>

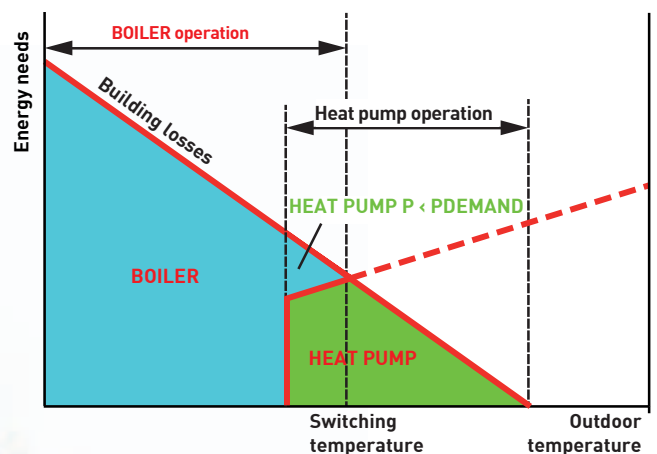

GAS  $\eta$  > HEAT PUMP COP

HEAT PUMP COP > GAS  $\eta$





## AQUACIAT2<sup>HYBRID</sup>

Opening up new possibilities

### A concept that is kind to the environment

Within an eco-design policy, hybrid technology reconciles environmental considerations and the difficulty of managing the energy mix, while still maintaining a high level of user comfort.

The Aquaciat2<sup>HYBRID</sup> is a hybrid heat pump which helps combat the greenhouse effect: the unit is emission-free in thermodynamic mode and only produces water and CO<sub>2</sub> in boiler mode.

The Aquaciat2<sup>HYBRID</sup> is particularly suited to urban environments, as it produces no noise pollution, either inside or outside. A night mode programmed for gas heating also prevents night-time noise disturbance for residents.

### Integration in CIAT indoor climate systems

For work spaces, in combination with other CIAT solutions, such as comfort units (fan coil units, cassettes, ductable units) Flowway dual-flow units and the intelligent Smart CIATControl system, the hybrid heat pump plays a central role in the ongoing quest for increased comfort and energy efficiency.

The Aquaciat2<sup>HYBRID</sup>'s *Optimal Water*® function optimises the building's restart time based on a learning calculation. Smart CIATControl also ensures automatic changeover of the main unit and the comfort units based on the building's requirements. The temperatures and the water consumption levels can also be consulted.



### Year-round comfort



The Aquaciat2<sup>HYBRID</sup> is particularly well-adapted to harsh winters because, in contrast to a simple air-to-water heat pump, it supplies a maximum heating capacity at very low outdoor temperatures.

The Aquaciat2<sup>HYBRID</sup> offers an energy-saving alternative by promoting the use of gas when the heat pump is not being used in defrost phases. In fact, it only defrosts when necessary, and in the shortest possible time thanks to the auxiliary gas boiler. This allows the user to benefit from high unit availability in the winter, as well as from an extended usable heating time and from comfort without the water temperature being lowered.

As there are no starting current peaks when using the boiler, any interference from the electricity network is eliminated and, if the power supply to a sensitive installation is cut, the Aquaciat2<sup>HYBRID</sup> can be controlled by a generator.



# AQUACIAT2<sup>HYBRID</sup>

## Innovation for professionals

### Plug & Heat installation

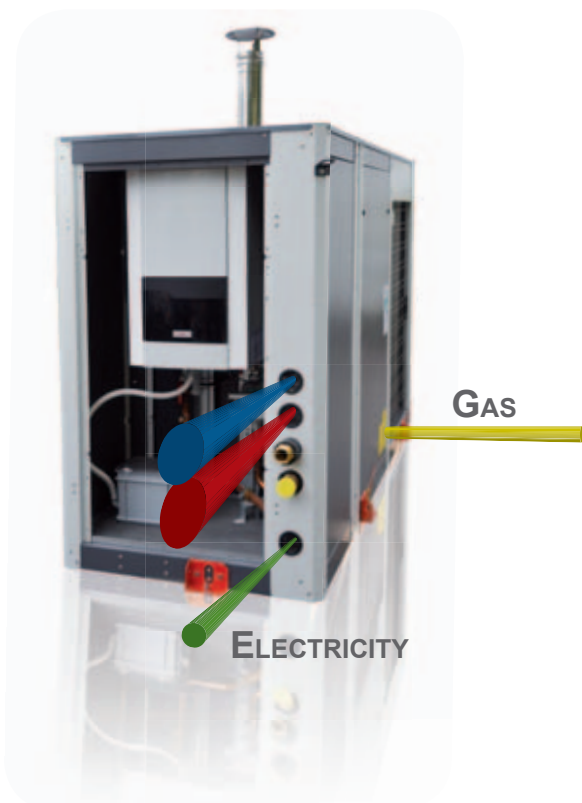

The Aquaciat2<sup>HYBRID</sup> offers two proven technologies known to professionals - an air-to-water electric heat pump and a condensation gas boiler.

The Plug & Heat design of the Aquaciat2<sup>HYBRID</sup>, hydraulically integrating a "standard" heat pump and a condensation boiler within a single casing, makes it simpler to set up the system and has a very slim design: compact dimensions, a single connection point, etc., make it possible to install the machines outdoors on small terraces.

### Safe operation

The hybrid technology is particularly safe for both the user and the contractor. The system is supplied with two complementary forms of energy – natural gas and electricity – reinforcing the safety of the installation, particularly in very cold conditions, and ensuring continuous operation under all circumstances.

The energy ruling means it is possible to control heating costs: electricity and gas bills are more regular and are only issued once the meter readings have been submitted.

### Condensation boiler

High annual efficiency, 102,4 % PCI

(source ELCO)

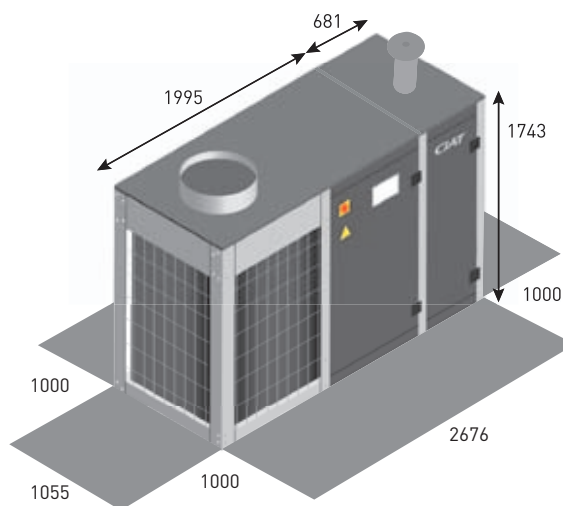

With over 80 years' experience, more than 2,000 employees and 6 production sites, including a vast industrial complex in the Rhône-Alpes region, CIAT has obtained ISO 14001 certification and is renowned as a major player in the HVAC industry.



## The CIAT Group: European leader in heating, cooling and indoor air quality



### An environmentally-responsible company working towards a greener world

For many years, CIAT has been pursuing an industrial policy based on an ongoing strategy of continued sustainable development and eco-design in order to minimise the environmental impact of its equipment. The equipment integrated into Hysys system solutions benefit from this commitment.

### A Group resolutely focused on innovation

CIAT's Centre for Research and Innovation, one of the largest in Europe, brings engineers and technicians together around a simulation platform dedicated to well-being. As a team, they constantly improve the comfort, IndoorAir Quality and energy performance levels of CIAT solutions to meet the requirements of consumer sectors.

### An exclusive network of advisers



Industry

Offices

Healthcare

Hotels

Shopping Centres

Administration Education

Residential

To ensure customer satisfaction, at CIAT we have organised our teams into seven centres of expertise. Operating in France and throughout Europe, our experts listen to your needs and, because they speak your language, they provide you with the best solution to meet your requirements.



[www.ciat.com](http://www.ciat.com)