

Toshiba Air Conditioning - RAS Data Sheet

RAS-16BKV-E

Mirai High-Wall Inverter



Features

- A new design that improves the energy efficiency of entry-tier level to A+/A+
- Operating range down to -15°C in cooling mode
- New high-wall with dustless heat exchanger and EZ service construction
- Self-diagnosis, hi-power, self-cleaning, ECO, off timer, swing and heating only compatibility
- Extra features with the optional controller: power select, comfort sleep, on-off timer, 8°C and weekly timer

Technical Data

Model reference indoor unit		RAS-16BKV-E
Nominal cooling	kW	4.6
Nominal heating	kW	5.4
UK cooling	kW	4.30
UK sensible cooling	kW	3.80
UK heating	kW	3.21
Annual power consumption	kWh	765
Sound pressure (cool/heat - high)	dB(A)	43/43
Air flow (cool/heat - high)	m ³ /h	750/768
Dimensions (H x W x D)	mm	293 x 798 x 230
Unit weight	kg	10
Model reference outdoor unit		RAS-16BAV-E
Maximum running current	A	TBC
Suggested fuse size	A	16
Power supply	V-ph-Hz	220/240-1-50
Interconnecting cable		3-core + earth
Sound pressure (cool/heat)	dB(A)	50/52
Air flow (cool/heat - high)	m ³ /h	2040/2160
Dimensions (H x W x D)	mm	550 x 780 x 290
Unit weight	kg	34
Pipe sizes (liquid-suction)	inch	1/4-1/2
Maximum pipe length/height difference	m	20/12
Pre-charge pipe length	m	15
Factory charge	kg	TBC
EER/COP		3.01/3.48
SEER/SCOP		6.2/4.2

Dimensional Drawings

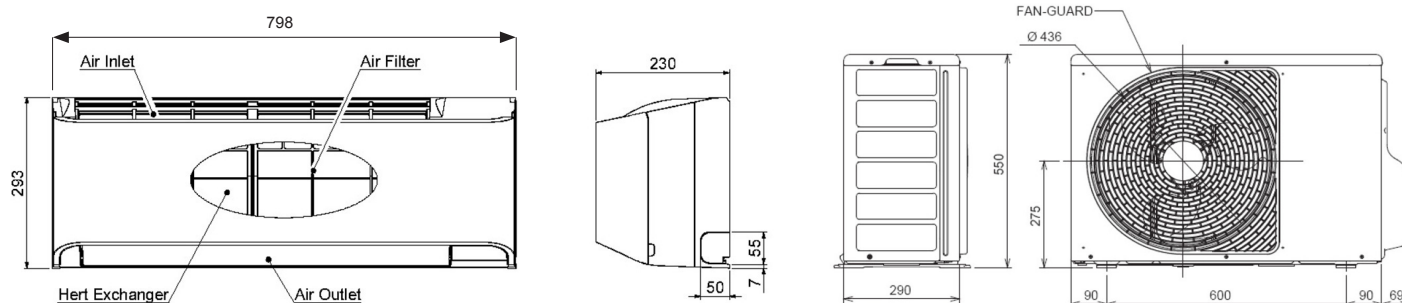

Cool Designs Ltd

Raising the Standards in Air Conditioning Distribution

www.cdlweb.info

