

Toshiba Air Conditioning - RAS Data Sheet

RAS-B10UFV-E Bi-Flow Console Inverter

Features

- Bi-flow (two air outlets for flow intensity)
- Fits perfectly under a standard window sill
- Easy-to-use remote control with extra-large display
- New Toshiba IAQ filtration system
- Auto-diagnostic function
- Unique floor heating function



Technical Data

Model reference indoor unit		RAS-B10UFV-E
Nominal cooling	kW	2.5
Nominal heating	kW	3.2
UK cooling	kW	2.48
UK sensible cooling	kW	2.15
UK heating	kW	2.05
Annual power consumption	kWh	298
Air flow (cool/heat - high)	m ³ /h	467/509
Sound pressure (cool/heat - high)	dB(A)	39/39
Dimensions (H x W x D)	mm	600 x 700 x 220
Unit weight	kg	16
Model reference outdoor unit		RAS-10N3AV2-E
System starting current	A	1
Suggested fuse size	A	10
Power supply	V-ph-Hz	220/240-1-50/60
Interconnecting cable		3-core + earth
Sound pressure (cool/heat)	dB(A)	46/47
Air flow (cool/heat - high)	m ³ /h	1800/1800
Dimensions (H x W x D)	mm	550 x 780 x 290
Unit weight	kg	33
Pipe sizes (liquid-suction)	inch	1/4-3/8
Maximum pipe length/height difference	m	20/10
Pre-charge pipe length	m	15
Additional refrigerant - factory charge	g/m - kg	20 - 1.05
EER/COP		3.25/3.81
SEER/SCOP		5.1/3.6

Dimensional Drawings

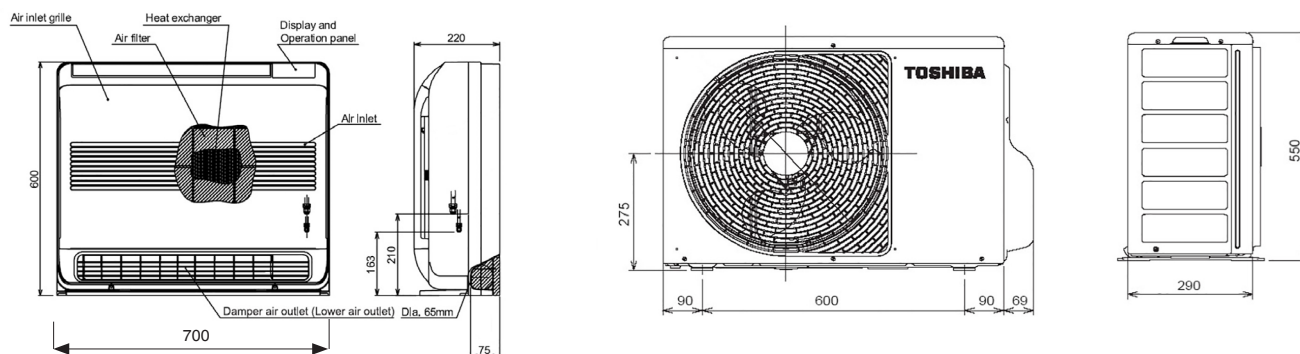

Cool Designs Ltd

Raising the Standards in Air Conditioning Distribution

www.cdlweb.info

